

PHILIPS

Data handbook



Electronic
components
and materials

Components and materials

Part 3

January 1981

Loudspeakers

COMPONENTS AND MATERIALS

PART 3 - JANUARY 1981

LOUDSPEAKERS

GENERAL (WITH SURVEY)

LOW POWER

MEDIUM POWER

HIGH POWER FULL RANGE

HIGH POWER TWEETERS

HIGH POWER SQUAWKERS

HIGH POWER WOOFERS

ACCESSORIES



DATA HANDBOOK SYSTEM

Our Data Handbook System is a comprehensive source of information on electronic components, sub-assemblies and materials; it is made up of four series of handbooks each comprising several parts.

ELECTRON TUBES	BLUE
SEMICONDUCTORS	RED
INTEGRATED CIRCUITS	PURPLE
COMPONENTS AND MATERIALS	GREEN

The several parts contain all pertinent data available at the time of publication, and each is revised and reissued periodically.

Where ratings or specifications differ from those published in the preceding edition they are pointed out by arrows. Where application information is given it is advisory and does not form part of the product specification.

If you need confirmation that the published data about any of our products are the latest available, please contact our representative. He is at your service and will be glad to answer your inquiries.

This information is furnished for guidance, and with no guarantee as to its accuracy or completeness; its publication conveys no licence under any patent or other right, nor does the publisher assume liability for any consequence of its use; specifications and availability of goods mentioned in it are subject to change without notice; it is not to be reproduced in any way, in whole or in part without the written consent of the publisher.

ELECTRON TUBES (BLUE SERIES)

Starting in 1980, new part numbers and corresponding codes are being introduced. The former code of the preceding issue is given in brackets under the new code.

Part 1	February 1980	T1 02-80 (ET1a 12-75)	Tubes for r.f. heating
Part 2	April 1980	T2 04-80 (ET1b 08-77)	Transmitting tubes for communications
Part 2b	May 1978	ET2b 05-78	Microwave semiconductors and components Gunn, Impatt and noise diodes, mixer and detector diodes, backward diodes, varactor diodes, Gunn oscillators, sub-assemblies, circulators and isolators.
Part 3	June 1980	T3 06-80 (ET2a 11-77)	Klystrons, travelling-wave tubes, microwave diodes
Part 3	January 1975	ET3 01-75	Special Quality tubes, miscellaneous devices
Part 4	September 1980	T4 09-80 (ET2a 11-77)	Magnetrons
Part 5a	October 1979	ET5a 10-79	Cathode-ray tubes Instrument tubes, monitor and display tubes, C.R. tubes for special applications.
Part 5b	December 1978	ET5b 12-78	Camera tubes and accessories, image intensifiers
Part 6	July 1980	T6 07-80 (ET6 01-77)	Geiger-Müller tubes
Part 7a	March 1977	ET7a 03-77	Gas-filled tubes Thyratrons, industrial rectifying tubes, ignitrons, high-voltage rectifying tubes.
Part 7b	May 1979	ET7b 05-79	Gas-filled tubes Segment indicator tubes, indicator tubes, switching diodes, dry reed contact units.
Part 8	July 1979	ET8 07-79	Picture tubes and components Colour TV picture tubes, black and white TV picture tubes, monitor tubes, components for colour television, components for black and white television.
Part 9	June 1980	T9 06-80 (ET9 03-78)	Photo and electron multipliers Photomultiplier tubes, phototubes, single channel electron multipliers, channel electron multiplier plates.

SEMICONDUCTORS (RED SERIES)

Starting in 1980, new part numbers and corresponding codes are being introduced. The former code of the preceding issue is given in brackets under the new code.

Part 1	March 1980	S1 03-80 (SC1b 05-77)	Diodes Small-signal germanium diodes, small-signal silicon diodes, special diodes, voltage regulator diodes (< 1,5 W), voltage reference diodes, tuner diodes, rectifier diodes
Part 2	May 1980	S2 05-80 (SC1a 08-78)	Power diodes, thyristors, triacs Rectifier diodes, voltage regulator diodes (> 1,5 W), rectifier stacks, thyristors, triacs
Part 2	June 1979	SC2 06-79	Low-frequency power transistors
Part 3	January 1978	SC3 01-78	High-frequency, switching and field-effect transistors*
Part 3	April 1980	S3 04-80 (SC211-77, partly) (SC301-78, partly)	Small-signal transistors
Part 4a	December 1978	SC4a12-78	Transmitting transistors and modules
Part 4b	September 1978	SC4b 09-78	Devices for optoelectronics Photosensitive diodes and transistors, light-emitting diodes, photocouplers, infrared sensitive devices, photoconductive devices
Part 5	October 1980	S5 10-80 (SC301-78)	Field-effect transistors
Part 7	December 1980	S7 12-80 (SC4c 07-78)	Discrete semiconductors for hybrid circuits

* Wideband transistors will be transferred to S10. The old book SC3 01-78 should be kept until then.

INTEGRATED CIRCUITS (PURPLE SERIES)

Starting in 1980, new part numbers and corresponding codes are being introduced. The former code of the preceding issue is given in brackets under the new code. Books with the purple cover will replace existing red covered editions as each is revised.

Part 1	May 1980	IC1 05-80 (SC5b 03-77)	Bipolar ICs for radio and audio equipment
Part 2	May 1980	IC2 05-80 (SC5b 03-77)	Bipolar ICs for video equipment
Part 5a	November 1976	SC5a 11-76	Professional analogue integrated circuits
Part 4	October 1980	IC4 10-80 (SC6 10-77)	Digital integrated circuits LOCMOS HE4000B family
Part 6b	August 1979	SC6b 08-79	ICs for digital systems in radio and television receivers
Signetics integrated circuits			Bipolar and MOS memories 1979 Bipolar and MOS microprocessors 1978 Analogue circuits 1979 Logic - TTL 1978

COMPONENTS AND MATERIALS (GREEN SERIES)

Starting in 1980, new part numbers and corresponding codes are being introduced. The former code of the preceding issue is given in brackets under the new code.

Part 1	July 1979	CM1 07-79	Assemblies for industrial use PLC modules, high noise immunity logic FZ/30 series, NORbits 60-series, 61-series, 90-series, input devices, hybrid integrated circuits, peripheral devices
Part 3a	September 1978	CM3a 09-78	FM tuners, television tuners, surface acoustic wave filters
Part 3	January 1981	C3 01-81 (CM3b 10-78)	Loudspeakers
Part 4a	November 1978	CM4a 11-78	Soft Ferrites Ferrites for radio, audio and television, beads and chokes, Ferroxcube potcores and square cores, Ferroxcube transformer cores
Part 4b	February 1979	CM4b 02-79	Piezoelectric ceramics, permanent magnet materials
Part 6	April 1977	CM6 04-77	Electric motors and accessories Small synchronous motors, stepping motors, miniature direct current motors
Part 7a	January 1979	CM7a 01-79	Assemblies Circuit blocks 40-series and CSA70 (L), counter modules 50-series, input/output devices
Part 8	June 1979	CM8 06-79	Variable mains transformers
Part 9	August 1979	CM9 08-79	Piezoelectric quartz devices Quartz crystal units, temperature compensated crystal oscillators
Part 10	October 1980	C10 10-80	Connectors
Part 11	December 1979	CM11 12-79	Non-linear resistors Voltage dependent resistors (VDR), light dependent resistors (LDR), negative temperature coefficient thermistors (NTC), positive temperature coefficient thermistors (PTC)
Part 12	November 1979	CM12 11-79	Variable resistors and test switches
Part 13	December 1979	CM13 12-79	Fixed resistors
Part 14	April 1980	C14 04-80 (CM2b 02-78)	Electrolytic and solid capacitors
Part 15	May 1980	C15 05-80 (CM2b 02-78)	Film capacitors, ceramic capacitors, variable capacitors

GENERAL



	page
Survey of types	A2
Conversion list	A6
Type number system	A11
Choice of type	A12
Response curves	A13
Terms and definitions	A13
Test methods and measurements	A14
Procedure for inspection	A22

SURVEY OF TYPES

The loudspeakers are divided into groups as shown in the survey below. *Conversion of catalogue number to type number is given in the list following this survey.*

LOW POWER LOUDSPEAKERS

basic part of type number	cone dimensions		shape of flange	impedance version Ω	power handling capacity W	page
	inches	mm				
AD0198/Z.	1½ φ	31 φ	round	8/15/25	0,3	B3
AD2071/Z.	2½ φ	64 φ	round	4/8/15/25/50/150	1	B7
AD2099/Z.	2 φ	50 φ	round	8/15/25	0,5	B11
AD3071/Y.	3 φ	81 φ	round	4/8/15/25/50/150	2	B15
AD3371/Y.	3 φ	81 φ	round	4/8/15/25/50/150	2	B15
AD4072/X.	4 φ	105 φ	round	4/8/15/25	3	B19
AD4472/X.	4 φ	105 φ	round	4/8/15/25	3	B19
AD4074/X.	4 φ	105 φ	round	4/8/15/25	2,5	B23
AD4474/X.	4 φ	105 φ	round	4/8/15/25	2,5	B23

MEDIUM POWER LOUDSPEAKERS

AD3080/M4	3 φ	87 φ	round	4	6	C3
AD3380/M4	3 □	87 □	square	4	6	C3
AD3080/X4	3 φ	87 φ	round	4	6	C7
AD3585/X.	3 x 5	75 x 130	oval	4/8/15/25/50/400	3	*
AD3595/X.	3 x 5	75 x 130	oval	4/8/15/25	3	C11
AD40800/X.	4 φ	102 φ	round	4	15	*
AD4085/X.	4 φ	105 φ	round	4/8/15	3	C15
AD4485/X.	4 □	105 □	square	4/8/15	3	C15
AD4095/X.	4 φ	105 φ	round	4/8/15/25	3	C19
AD4495/X.	4 □	105 □	square	4/8/15/25	3	C19
AD4481/X.	4 □	105 □	square	4/8	8	C23
AD4681/M.	4 x 6	102 x 154	oval	4/8/25	6	C27
AD4681/X.	4 x 6	102 x 154	oval	4/8/15/25	6	C31
AD4682/X.	3½ x 6	94 x 154	oval	4/8/15/25	6	C35
AD4683/M.	4 x 6	102 x 154	oval	4/8/15/25	6	C39
AD4683/X.	4 x 6	102 x 154	oval	4/8/15/25	6	C43
AD4684/X.	3½ x 6	94 x 154	oval	4/8/15/25	6	C47
AD4685/X.	3½ x 6	94 x 154	oval	4/8	4	C51
AD4686/X.	4 x 6	102 x 154	oval	4/8/15/25	4	C55
AD4691/M.	4 x 6	102 x 154	oval	4/8/15/25	6	C59
AD4691/X.	4 x 6	102 x 154	oval	4/8/15/25	6	C63
AD4692/X.	3½ x 6	94 x 154	oval	4/8/15/25	4	C67
AD46920/X.	4 x 6	94 x 154	oval	4/8/15/25	4	C71
AD4696/X.	4 x 6	102 x 154	oval	4/8/15/25	4	C75
AD48900/X.	4 x 8	96 x 210	oval	4/8/15/25	10	C79
AD4891/X.	4 x 8	96 x 210	oval	4/8/15/25	10	C83

* Extended information available shortly.

MEDIUM POWER LOUDSPEAKERS (continued)

basic part of type number	cone dimensions		shape of flange	impedance version Ω	power handling capacity W	page
	inches	mm				
AD5081/M.	5 ϕ	120 ϕ	round	4/8/15/25	6	C87
AD5081/X.	5 ϕ	120 ϕ	round	4/8/15/25	6	C91
AD5780/M.	5 x 7	132 x 182	oval	4/8/16/25	6	C95
AD5780/X.	5 x 7	132 x 182	oval	4/8/15/25	6	C99
AD57900/X.	5 x 7	132 x 182	oval	4/8	10	C103
AD5791/M.	5 x 7	132 x 182	oval	4/8	10	C107
AD7080/M.	7	165	octagonal	4/8/15	6	C111
AD7080/X.	7	165	octagonal	4/8	6	C115
AD7081/M4	7	165	octagonal	4	10	C119
AD7090/X.	7	165	octagonal	4/8	4	C123
AD8081/M.	8	205	octagonal	4/8	8	C127
AD8081/X.	8	205	octagonal	4/8	8	C131
AD8082/M.	8	205	octagonal	4/8	13	C135
AD8082/X8	8	205	octagonal	8	13	C139

HIGH POWER FULL-RANGE LOUDSPEAKERS

AD40400/M4	4	102 ϕ	round	4	15	D3
AD4060/M.	4 ϕ	102 ϕ	round	4/8	20	D7
AD40900/M.	4 ϕ	102 ϕ	round	4/8/15/25	8	D11
AD5061/M.	5	128 ϕ	octagonal	4/8	10	D15
AD51600/P4	5 1/4	131 x 131	squared circle	4	20	D19
AD57900/M.	5 x 7	183	oval	4/8	10	D23
AD7062/M.	7	166	octagonal	4/8	30	D27
AD70620/M.	7 ϕ	166 ϕ	round	4/8	30	D31
AD7063/M.	7	166	octagonal	4/8	10	D35
AD70630/M.	7 ϕ	166 ϕ	round	4/8	20	D39
AD7064/M.	7	166	octagonal	4/8	20	D43
AD7065/M4	7	166	octagonal	4	20	D47
AD9710/M8	8 1/2 ϕ	217 ϕ	round	8	20	D51
AD1065/M.	10 ϕ	261 ϕ	round	4/8/15	10	D55
AD12100/HP.	12 ϕ	311 ϕ	round	4/8	50	D59
AD12100/M.	12 ϕ	311 ϕ	round	4/8/15	25	D63
AD1265/M.	12 ϕ	311 ϕ	round	4/8/15	20	D67

HIGH POWER TWEETER LOUDSPEAKERS

basic part of type number	cone dimensions		shape of flange	impedance version Ω	power handling capacity W	page
	inches	mm				
AD00400/T.	3/4 □	83 □	square	4/8	6	E3
AD00800/T.	3/4 □	83 □	square	4/8	6	E7
AD00900/T.	3/4 □	58 □	square	4/8	6	E11
AD0140/T.	1 ϕ	94 ϕ	round	4/8	4	E15
AD01404/T.	1 ϕ	94 ϕ	round	4/8	4	E19
AD0141/T.	1 ϕ	94 ϕ	round	4/8	4	E23
AD01420/T.	1 □	96 □	square	4/8/15	3,5	E27
AD01421/T.	1 □	96 □	square	4/8/15	3,5	E27
AD01430/T.	1 □	96 □	square	4/8/15	3,5	E31
AD01431/T.	1 □	96 □	square	4/8/15	3,5	E31
AD0147/T.	1 ϕ	83 ϕ	round	8/15	3,5	E35
AD01600/T.	1 □	96 □	square	4/8/15	4	E39
AD01605/T.	1 □	96 □	square	4/8/15	4	E39
AD01610/T.	1 □	96 □	square	4/8/15	4	E43
AD0162/T.	1 ϕ	94 ϕ	round	8/15	4	E47
AD01624/T.	1 ϕ	94 ϕ	round	4/8	4	E51
AD0163/T.	1 ϕ	94 ϕ	round	8/15	4	E55
AD01630/T.	1 □	96 □	square	8/15	4	E59
AD01631/T.	1 □	96 □	square	8/15	4	E59
AD01632/T.	1 □	96 □	square	8/15	6	E63
AD01633/T.	1 □	96 □	square	8/15	6	E63
AD01634/T.	1 ϕ	94 ϕ	round	4/8	4	E67
AD2096/T.	2 ϕ	50 ϕ	round	4/8/15	3	E71
AD2296/T.	2 □	53 □	square	4/8/15	3	E71
AD22300/T.	2 □	53 □	square	4/8/15	3	E75
AD2273/T.	2 1/2 □	58 □	square	4/8/15	10	E79
AD2274/T.	2 1/2 □	58 □	square	4/8/15	10	E79

HIGH POWER SQUAWKER LOUDSPEAKERS

AD0210/Sq	2 ϕ	134 ϕ	round	4/8	50	F3
AD0211/Sq	2 ϕ	134 ϕ	round	4/8	50	F3
AD02110/Sq	2 □	134 □	square	4/8	30	F7
AD02150/Sq	2 □	134 □	square	4/8	30	F11
AD02160/Sq	2 □	134 □	square	4/8	30	F15
AD02161/Sq	2 □	134 □	square	4/8	30	F15
AD5060/Sq	5	128	octagonal	4/8	30	F19
AD50600/Sq	5	129 x 129	squared circle	4/8	20	F23
AD50601/Sq	5	129 x 129	squared circle	4/8	20	F27
AD5061/Sq	5	129	octagonal	4/8	10	F31
AD5062/Sq	5	128	octagonal	4/8	50	F35
AD50800/Sq	5	129 x 129	squared circle	4/8	15	F39
AD50801/Sq	5	125 x 125	squared circle	4/8	15	F43

HIGH POWER WOOFER LOUDSPEAKERS

basic part of type number	cone dimensions		shape of flange	impedance version Ω	power handling capacity W	page
	inches	mm				
AD40500/W.	4 ϕ	102 ϕ	round	4/8	15	G3
AD40501/W.	4 ϕ	102 ϕ	round	4/8	20	G7
AD4060/W.	4 ϕ	102 ϕ	round	4/8	15	G11
AD40900/W.	4 ϕ	102 ϕ	round	4/8	15	G15
AD40910/W4	4 ϕ	102 ϕ	round	4	12	G19
AD5060/W.	5	129	octagonal	4/8	10	G23
AD5062/W.	5	129	octagonal	4/8	20	*
AD70601/W.	7 ϕ	166 ϕ	round	4/8	30	G27
AD70602/W.	7 ϕ	166 ϕ	round	4/8	30	G27
AD70610/W.	7 ϕ	166 ϕ	round	4/8	30	G31
AD70611/W.	7 ϕ	166 ϕ	round	4/8	30	G31
AD70650/W.	7 ϕ	166 ϕ	round	4/8	40	G35
AD70652/W.	7 ϕ	166 ϕ	round	4/8	40	G39
AD80601/W.	8 ϕ	204 ϕ	round	4/8	50	G43
AD80602/W.	8 ϕ	204 ϕ	round	4/8	50	G43
AD70800/W6	7	166	octagonal	8	25	*
AD80110/W8	8	204	—	8	60	*
AD80603/W.	8 ϕ	204 ϕ	round	4/8	50	G47
AD80604/W.	8 ϕ	204 ϕ	round	4/8	50	G51
AD80605/W6	8 ϕ	204 ϕ	round	6	40	G55
AD80651/W.	8 ϕ	204 ϕ	round	4/8	50	G59
AD80652/W.	8 ϕ	204 ϕ	round	4/8	50	G59
AD80671/W.	8 ϕ	204 ϕ	round	4/8	60	G63
AD80672/W.	8 ϕ	204 ϕ	round	4/8	60	G63
AD10100/W.	10 ϕ	261 ϕ	round	4/8	40	G67
AD10600/W8	10 ϕ	259 ϕ	round	8	40	G71
AD12200/W.	12 ϕ	311 ϕ	round	4/8	80	G75
AD12250/W.	12 ϕ	311 ϕ	round	4/8	100	G79
AD12600/W.	12 ϕ	311 ϕ	round	4/8	40	G83
AD12650/W.	12 ϕ	311 ϕ	round	4/8	60	G87

ACCESSORIES Passive radiators

AD8001	8 ϕ	205 ϕ	round	—	—	H3
AD8002	8 ϕ	205 ϕ	round	—	—	H3
AD1200	12 ϕ	311 ϕ	round	—	—	H5

* Extended information available shortly.

GENERAL

CONVERSION LIST

Conversion of catalogue number stamped on loudspeaker to type number. See relevant data sheet for ordering number.

catalogue number	type number	catalogue number	type number
2403 256 12101	AD0198/Z25	2404 257 46101	AD70620/M4
12102	Z15	46102	M8
12103	Z8		
2403 257 22101	AD2273/T4	2422 256 22201	AD2099/Z25
22102	T8	22202	Z15
22201	AD2274/T4	22203	Z8
22202	T8	24301	AD4095/X4
23501	AD3371/Y4	24302	X8
23502	Y8	24303	X15
23503	Y15	24304	X25
23504	Y25	24311	AD4495/X4
23505	Y50	24312	X8
23506	Y150	24313	X15
23601	AD3071/Y4	24314	X25
23602	Y8	30311	AD3595/X4
23603	Y15	30312	X8
23604	Y25	30313	X15
23605	Y50	30314	X25
23606	Y150	30601	AD4691/X4
23801	AD2071/Z4	30602	X8
23802	Z8	30603	X15
23803	Z15	30604	X25
23804	Z25	30612	M4
23805	Z150	30614	M15
23806	Z50	30615	M8
24205	AD4072/X4	30616	M25
24206	X8	30711	AD4891/X4
24207	X15	30712	X8
24208	X25	30713	X15
24305	AD4074/X4	30714	X25
24306	X8	30801	AD4692/X4
24307	X15	30802	X8
24308	X25	30803	X15
24705	AD4474/X4	30804	X25
24706	X8	32301	AD2096/T4
24707	X15	32302	T8
24708	X25	32303	T15
24805	AD4472/X4	32311	AD2296/T4
24806	X8	32312	T8
24807	X15	32313	T15
24808	X25	36011	AD5791/M4
		36012	M8
2404 257 35411	AD5062/Sq4	37101	AD7090/X4
35412	Sq8	37102	X8
46001	AD7062/M4	40101	AD4696/X4
46002	M8	40102	X8
		40103	X15

catalogue number	type number	catalogue number	type number
2422 256 40104	AD4696/X25	2422 257 32202	AD02110/Sq8
2422 257 21011	AD12600/W4	32301	AD02150/Sq4
21012	W8	32302	Sq8
24301	AD4085/X4	32311	AD02160/Sq4
24302	X8	32312	Sq8
24303	X15	32315	AD02161/Sq4
24311	AD4485/X4	32316	Sq8
24312	X8	32511	AD22300/T4
24313	X15	32512	T8
30401	AD4681/X4	32513	T15
30402	X8	33111	AD01420/T4
30403	X15	33112	T8
30404	X25	33113	T15
30409	M4	33115	AD01430/T4
30411	M8	33116	T8
30413	M25	33117	T15
30501	AD4683/X4	33201	AD0140/T4
30502	X8	33202	T8
30503	X15	33208	AD01404/T4
30504	X25	33209	T8
30505	M4	33211	AD0141/T4
30506	M8	33212	T8
30507	M15	33311	AD0162/T4
30508	M25	33312	T8
30601	AD4682/X4	33313	T15
30602	X8	33315	AD01624/T4
30603	X15	33316	T8
30604	X25	33402	AD0163/T8
30701	AD4685/X4	33403	T15
30702	X8	33411	AD01634/T4
30801	AD4686/X4	33412	T8
30802	X8	33501	AD01600/T4
30803	X15	33502	T8
30804	X25	33503	T15
30901	AD4684/X4	33511	AD01605/T4
30902	X8	33512	T8
30903	X15	33513	T15
30904	X25	33601	AD01610/T4
31411	AD12650/W4	33602	T8
31412	W8	33603	T15
31511	AD12200/W4	33701	AD00400/T4
31512	W8	33702	T8
31602	AD10600/W8	33711	AD00800/T4
32001	AD0210/Sq4	33712	T8
32002	Sq8	33802	AD01630/T8
32011	AD0211/Sq4	33803	T15
32012	Sq8	33806	AD01632/T8
32201	AD02110/Sq4	33807	T15



GENERAL

catalogue number	type number
2422 257 33812	AD01631/T8
33813	T15
33816	AD01633/T8
33817	T15
34311	AD4481/X4
34417	AD4481/X8
34501	AD3380/M4
34517	AD3080/M4
34519	X4
34601	AD4060/W4
34602	W8
34605	AD40400/M4
34617	M8
34619	M4
34701	AD40500/W4
34702	W8
34703	AD40501/W4
34704	W8
34801	AD40900/W4
34802	W8
34805	AD40910/W4
34811	AD40900/M4
34812	M8
34813	M15
34814	M25
35301	AD5060/W4
35302	W8
35401	AD5060/Sq4
35402	Sq8
35405	AD5061/Sq4
35406	Sq8
35511	M4
35512	M8
35701	AD5081/X4
35702	X8
35703	X15
35704	X25
35705	AD5081/M4
35706	M8
35707	M15
35708	M25
35805	AD51600/P4
36101	AD5780/X4
36102	X8
36103	X15
36104	X25
36105	M4
36106	M8
36107	M15
36108	M25

catalogue number	type number
2422 257 36201	AD57900/X4
36202	X8
36205	M4
36206	M8
37801	AD7080/X4
37802	X8
37803	M4
37804	M8
37805	M15
37906	AD7063/M4
37907	M8
37913	AD7064/M4
37914	M8
37915	AD70610/W4
37916	W8
37917	AD70611/W4
37918	W8
38211	AD8081/M4
38212	M8
38213	X4
38214	X8
38215	AD8082/M4
38216	M8
38218	X8
40001	AD46920/X4
40002	X8
40003	X15
40004	X25
40101	AD48900/X4
40102	X8
40103	X15
40104	X25
41001	AD1065/M4
41002	M8
41003	M15
41101	AD1265/M4
41102	M8
41103	AD1265/M15
41201	AD10100/W4
41202	W8
43005	AD0147/T4
43006	T8
43007	T15
43101	AD00900/T4
43102	T8
43201	AD01421/T4
43202	T8
43203	T15
43204	AD01431/T4
43205	T8

catalogue number	type number
2422 257 43206	AD01431/T15
45001	AD50600/Sq4
45002	Sq8
45011	AD50601/Sq4
45012	Sq8
45101	AD50800/Sq4
45102	Sq8
45111	AD50801/Sq4
45112	Sq8
47019	M4
47101	AD70601/W4
47102	W8
47103	AD70630/M4
47104	M8
47111	AD70602/W4
47112	W8
47201	AD70650/W4
47202	W8
47211	AD70652/W4
47212	W8
48101	AD9710/M8
48201	AD80601/W4
48202	W8
48205	AD80603/W4
48206	W8

catalogue number	type number
2422 257 48207	AD80604/W4
48208	W8
48305	AD80605/W6
48311	AD80602/W4
48312	W8
48401	AD80651/W4
48402	W8
48511	AD80652/W4
48512	W8
48601	AD80671/W4
48602	W8
48711	AD80672/W4
48712	W8
51001	AD12100/M4
51002	M8
51003	M15
51101	AD12100/HP4
51102	HP8
61011	AD12250/W4
61012	W8
2422 259 12001	AD1200
80001	AD8001
80002	AD8002



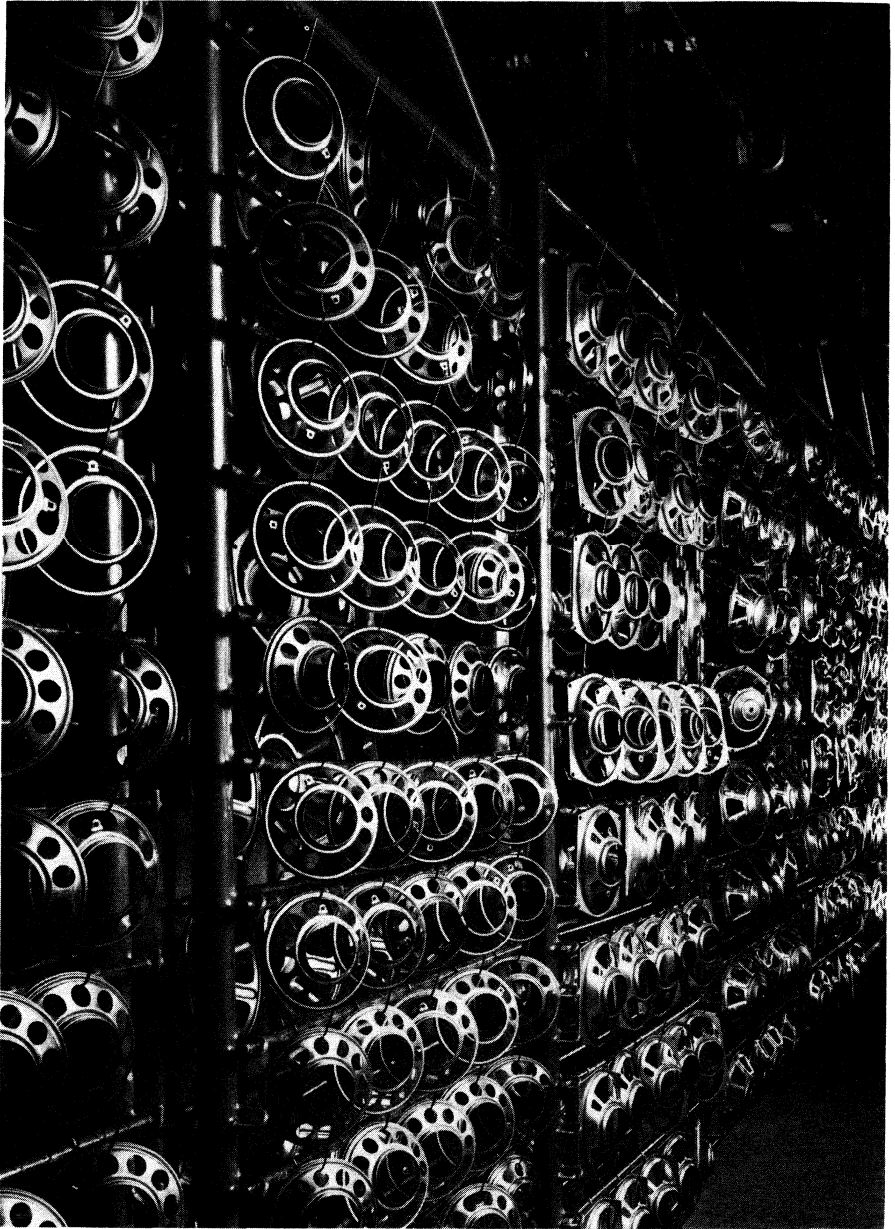

|||||

TYPE NUMBER SYSTEM

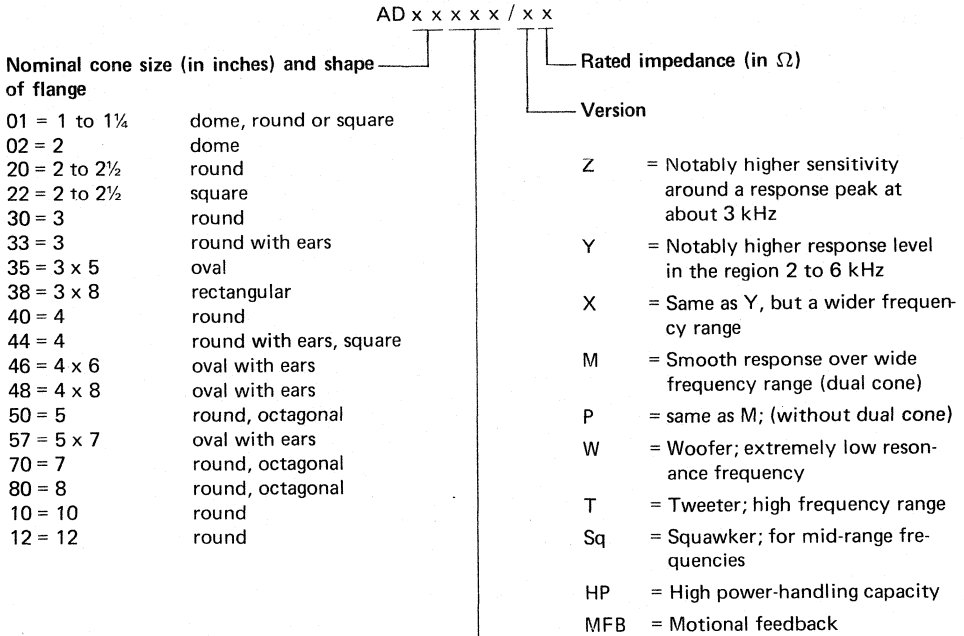

Magnet system

- 10 = ceramic, 102 mm φ
- 40 to 49 = ceramic, 60 mm φ
- 400 to 449 = ceramic, 60 mm φ
- 500 to 559 = ceramic, 60 – 69 mm φ with compensation
- 60 to 64 = ceramic, 72 mm φ
- 600 to 649 = ceramic, 72 mm φ
- 65 to 67 = ceramic, 90 mm φ
- 650 to 679 = ceramic, 90 mm φ
- 70 to 74 = ceramic, 30 mm φ
- 80 to 84 = ceramic, 53 mm φ
- 800 to 849 = ceramic, 53 mm φ
- 85 to 89 = ceramic, 46 mm φ
- 90 to 94 = steel alloy, 18 mm φ
- 900 to 949 = ceramic, 40 to 49 mm φ with compensation
- 95 to 97 = steel alloy, 14 mm φ
- 98, 99 = steel alloy, 10 mm φ
- 100 = ceramic, 130 mm φ
- 200 = ceramic, 125 mm φ
- 250 = ceramic, 138 mm φ

Example: AD01632/T8 = 1-inch dome, 72 mm φ ceramic magnet, tweeter, 8 Ω.

CHOICE OF TYPE

A correctly chosen loudspeaker is essential to obtain adequate acoustic results from electro-acoustic equipment.

The following factors should be considered when choosing a loudspeaker:

- Shape, size and attachment with reference to the available space;
- Quality and sensitivity, a compromise between fidelity of reproduction and price;
- The frequency response characteristic in relation to the kind of application;
- Impedance and power handling capacity, which should be adapted to the output stage of the equipment;
- Appearance and finish.

To assist customers in making their choice, our loudspeakers have been divided into three main groups:

- High power (hi-fi/full range);
- Medium power;
- Low power.

The high power series comprises top-quality woofers, squawkers and tweeters intended for use in special combinations with appropriate filters and enclosures. Their excellent sound reproduction conforms in every respect to the high fidelity standards IEC 268 and DIN 45 500. The system power handling capacity is from 10 W to 250 W - the latter for theatres and outdoor applications. Full range high power loudspeakers are also available. These speakers also conform to IEC 268 and DIN 45 500 but have been designed to meet somewhat less stringent requirements. They are specially for juke boxes, musical instruments, monitoring and public address systems.

The medium power series may be subdivided according to the application into round and oval versions, usually for radio, audio and television. Loudspeakers having a metal magnet system - which keeps stray magnetic fields low - are particularly recommended for television.

The low power types are mainly used in small radios, intercoms and portable television.

RESPONSE CURVES

For the medium and low power range, a curve of a loudspeaker mounted on an IEC baffle, showing the sound pressure as a function of the frequency, is normally given in the data sheets.

For the high power range, curves are given of a loudspeaker mounted on an IEC baffle or mounted in an enclosure.

TERMS AND DEFINITIONS

Unmounted: The loudspeaker is placed in a clamping set-up which does not influence its radiation characteristics.

Mounted in enclosure: The loudspeaker is front mounted in an enclosure of the dimensions specified on the data sheet.

Baffle: The loudspeaker is fitted to a baffle of the dimensions specified on the data sheet (flush mounted or front mounted).

Half free field: The acoustical conditions on the forward side approach those of free space.

Anechoic room: The acoustical conditions approach those of free space (IEC Publication 268, Part 5, Section 1).

Operating power: Is the sinewave power input to the loudspeaker which corresponds with a sound level of 96 dB with respect to 0,02 mPa at a microphone distance of 1 m. This sound level is the average level over the rated frequency range of the loudspeaker.

Maximum power: The power of a continuous sinusoidal signal within the rated frequency range which the loudspeaker element or system can handle for ten minutes without any damage, e.g. either thermal or mechanical deformation.

Characteristic sensitivity: The sound pressure produced at a distance of 1 m when the loudspeaker is supplied with a pink noise signal, the voltage of which corresponds to a power of 1 W in the rated impedance.

Compliance: The reciprocal of the stiffness of the suspension.



TEST METHODS AND MEASUREMENTS

The atmospheric conditions for measurement are:

Temperature:	15 to 35 °C
Relative humidity:	45 to 75 %
Pressure:	860 to 1060 mbar

1 Impedance

The impedance is the modulus of the lowest value of the electrical impedance in the frequency range above the bass resonance frequency of the loudspeaker as determined by the method specified in 3 below.

1.1 Measuring apparatus

See under 3. In Fig. 1, $R = 1 \Omega$.

1.2 Conditions

- The loudspeaker is unmounted.
- The power input to the loudspeaker will not exceed 0,1 x the power-handling capacity as determined in 4 below.

1.3 Measuring result

Rated impedance is stated in the data sheets. The measured impedance will not be lower than 20% of the rated impedance.

2 Voice coil resistance

The voice coil resistance is the d.c. resistance of the voice coil.

2.1 Measuring apparatus

Low current d.c. ohmmeter.

2.2 Conditions

The d.c. power input to the loudspeaker does not exceed 0,1 x the power-handling capacity.

2.3 Measuring result

The rated resistance is given in the data sheets, tolerance $\pm 10\%$.

3 Resonance frequency

The resonance frequency is that frequency where the modulus of the electrical impedance has its first principal maximum in an ascending scale, the electrical input being such as to have no significant effect on the resonant frequency.

3.1 Measuring apparatus

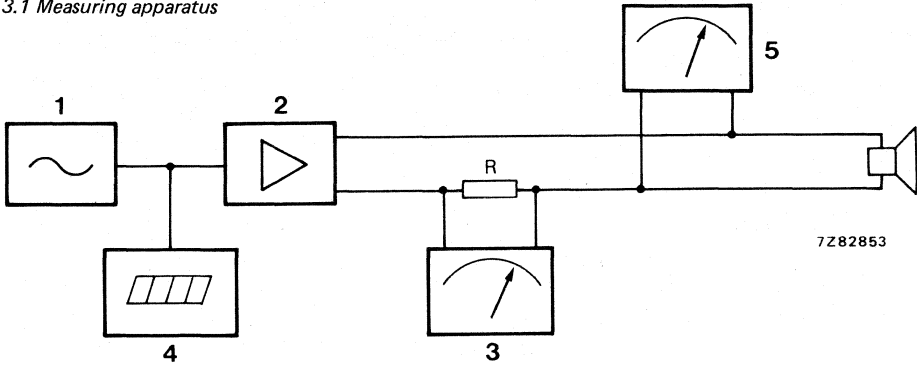

Fig. 1.

- (1) Sinewave generator, Philips PM5126.
 - (2) Power amplifier.
 - (3) and (5) a.c. mV meter, Philips PM2454.
 - (4) Frequency counter, Philips PM6620.
- } or equivalents
- R = 0,1 Ω.

3.2 Conditions

- The loudspeaker is measured unmounted.
- Resonance frequency is measured at least 24 hours after fabrication of the loudspeaker.
- No measurements or tests are carried out before measurement of the resonance frequency.
- Power on the loudspeaker: 1 W.

3.3 Measuring result

The resonance frequency is that frequency at which the voltmeter indicates the first minimum deflection as the frequency is swept slowly from 0 Hz.

The resonance frequency is stated in the data sheets, tolerance ± 15%.

4 Power handling capacity

The power handling capacity is the nominal power which the loudspeaker will satisfactorily handle as checked by an accelerated life test.

4.1 Measuring apparatus

- Generator supplying test signal in accordance with IEC Publication 268, Part 5, Section 9.3.
- Power amplifier with an output impedance not greater than 1/3 of the rated impedance of the loudspeaker.
- Voltmeter indicating the r.m.s. value of the voltage.

4.2. Conditions

- A test voltage is applied to the loudspeaker for an uninterrupted period of 100 h. The r.m.s. value of this voltage corresponds with the specified power handling capacity of the loudspeaker.
- The test voltage has a frequency distribution corresponding with that of the output of a filter as specified in IEC Publication 268, Part 5, Section 9.3 when fed from a white noise source.

- If the loudspeaker is designed to operate in a restricted frequency range, the corresponding network (filter) which is connected to the loudspeaker during the test, is specified in the data sheet. The test voltage is measured at the input terminals of the network.
- The method of mounting is as specified in the data sheet.

4.3 Measuring result

To pass this test the loudspeaker has to function properly at the end of the test period. Deviation from the specified resonance frequency is allowed. Refer to 11 (Life test).

5 Total non-linear distortion

This is the ratio between the r.m.s. value of the harmonic content of the sound pressure to the value of the total sound pressure over the frequency range of the loudspeaker

The difference in dB between fundamentals and harmonic contents, can be converted into a distortion percentage with the aid of following nomogram.

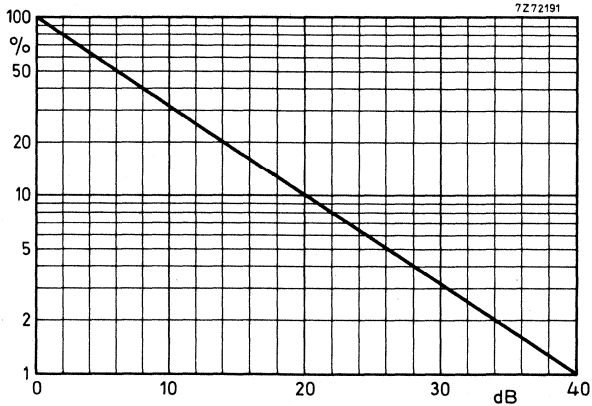
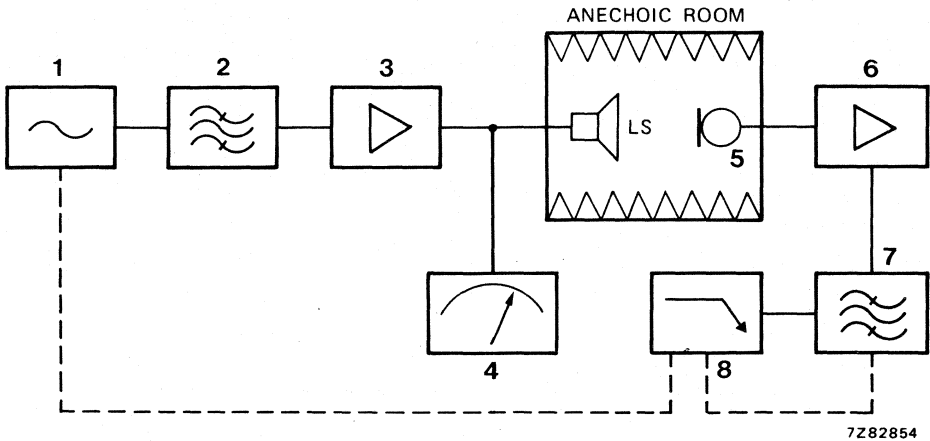

Fig. 2 Difference in dB converted into % distortion.

5.1 Measuring apparatus



7Z82854

Fig. 3.

- | | |
|---|------------------|
| <ul style="list-style-type: none"> (1) Sinewave generator, Bruel & Kjaer, type 1027. (2) Bandpass filter, Krohn - Hite, type 3700. (3) Power amplifier, Bruel & Kjaer, type 2706. (4) Electronic voltmeter, Bruel & Kjaer, type 2425. (5) Microphone, Bruel & Kjaer, type 4145. (6) Measuring amplifier, Bruel & Kjaer, type 2608. (7) Bandpass filter set, Bruel & Kjaer, type 1615. (8) Level recorder, Bruel & Kjaer, type 2307. | } or equivalents |
|---|------------------|

5.2 Conditions

- The loudspeaker is mounted as specified in the data sheet.
- The power input to the loudspeaker is the operating power (see under Terms and Definitions).
- The microphone distance is 1 m unless otherwise specified in the data sheet.

5.3 Measuring result

The distortion curve of high power loudspeakers is given in the data sheet.

6 Sweep voltage

The sweep voltage test involves the loudspeaker receiving a sinusoidal test signal of specified constant amplitude. The frequency of this signal is swept through the specified frequency range.

6.1 Measuring apparatus

- Audio-frequency sinewave generator with a constant output voltage over the range from 0 to 20 000 Hz.
- Linear amplifier with an output power appropriate to the loudspeaker under test and an output impedance not greater than $1/3 \times$ the rated loudspeaker impedance. For power see 6.2.
- An electronic voltmeter with high input impedance.

6.2 Conditions

- The loudspeaker is tested unmounted.
- The input voltage is:
 - (a) for the *medium and low power range* such that the power input to the loudspeaker is 0,5 x the specified power handling capacity.
 - (b) for the *high power range* as specified in the data sheets.
- If the loudspeaker is designed to operate in a restricted frequency range, the corresponding network (filter) which is connected to the loudspeaker during the test, is specified in the data sheet. The test voltage is measured at the input terminals of the network.

6.3 Measuring result

The sound reproduction must be correct and undistorted. (The faults can be classified according to the fault list mentioned in 'Procedure of inspection for loudspeakers'.)

7 Flux density

This is the magnetic flux density measured in the air gap.

7.1 Measuring apparatus

- Differential search coil pair.
- Galvanometer.

7.2 Conditions

- The distance between the centres of the two coils is equal to the air-gap height minus 1 mm.
- The two coils are put into the air gap symmetrical with respect to the pole plate.

7.3 Measuring result

The minimum flux density as measured on production samples is stated in the data sheet.

8 Frequency response

The frequency response is the graph representing the sound pressure as a function of frequency applying to the loudspeaker a constant sinewave signal V.

8.1 Measuring apparatus

- Microphone, Bruel & Kjaer, type 4131, 4145.
 - Microphone amplifier, Bruel & Kjaer, type 2606, 2607, 2608.
 - Cathode follower, Bruel & Kjaer, type 2619.
 - Sine/random generator, Bruel & Kjaer, type 1024.
 - Level recorder, Bruel & Kjaer, type 2305, 2307.
- } or equivalents

The apparatus is set as follows:

- Writing speed, 125 mm/s
- Paper speed, 3 mm/s
- Range potentiometer, 50 dB
- Lower limiting frequency, 10 Hz
- Rectifier response, r.m.s.
- Writing width, 100 mm
- Compressor speed, 300 dB/s

8.2 Conditions

– Sinewave signal $V = \sqrt{P \cdot Z_r}$,

where:

for anechoic room measurements $P = 50$ mW, unless otherwise stated in the data sheets.

V = test voltage,

Z_r = rated impedance as specified in the data sheet.

– Microphone position: in axis of loudspeaker at a distance of 0,5 m for anechoic room measurements.

8.3 Measuring result

A description of the sensitivity and the frequency response curve(s) are given in the data sheet.

9 Direction of magnetization

The magnet is so magnetized that the centre-pole is *south* for systems with a ring magnet, and *north* for systems with a slug magnet.

10 Polarity

The cone of the loudspeaker will move outwards when a d.c. voltage is applied to the terminals so that the red terminal is positive. The voltage applied does not exceed the "sweep voltage".

11 Life test

11.1 Measuring apparatus

- Pink noise generator, Bruel & Kjaer, type 1405 or equivalent.
- Filter and limiting circuit.
- Emitter follower.
- Power amplifier.
- Electronic r.m.s. voltmeter, Bruel & Kjaer, type 2425 or equivalent.

For tests on tweeters and squawkers a high-pass filter, as mentioned in the data sheet for power handling capacity measurement, must be used between amplifier and speaker.

11.2 Conditions

The output of the generator must be adjusted so that the output peak voltage of the limiter is twice the r.m.s. value.

Voltage on the loudspeaker:

$$V_{rms} = \sqrt{P \cdot Z_r}$$

P = power handling capacity of the relevant loudspeaker.

Z_r = rated impedance as specified in the data sheet.

The loudspeaker will be tested mounted in an enclosure, if it is mentioned in the relevant data sheet.

11.3 Measuring result

After 100 hours the speaker must still meet the requirements stated in the data sheet, except for the resonance frequency, which may be decreased beneath 85%.





12 Climatic tests

test	procedure	recovery time	requirements
dry heat change of temperature	7 days at + 70 °C, loudspeaker unloaded 24 h at -25 °C loudspeaker 8 - 12 h at + 25 °C unloaded 24 h at + 70 °C 4 h at + 25 °C	4 h —	no important changes in electrical, mechanical and acoustical properties, except for the resonance frequency
humidity cycle	12 h at + 45 °C, 85% R.H. 12 h at + 25 °C, 100% R.H. 21 days	4 h	
endurance	100 h at + 45 °C loudspeaker loaded with P.H.C. ref. IEC publ. 268-5-9	4 h	
endurance* under humid conditions	as humidity cycle test, but loudspeaker loaded with ½ P.H.C.		
short overload	3 h at + 45 °C, loaded with P.H.C. followed by 10 min loaded with P _{max}	4 h	

* On request only.

PROCEDURE FOR INSPECTION OF LOUDSPEAKERS

This procedure is applicable:

- for measuring the quality of loudspeakers lots, packed and ready for dispatch to a receiver/user.
- for batch acceptance.

It provides the specification of defects on loudspeakers after inspection by attributes. The types of inspection are: visual inspection, auditive inspection and several measurements. If necessary additional information can be laid down in the Specific Conditions of the Quality Agreement regarding to the deliveries between supplier and customer.

The defects are grouped into two classes:

- Major defects,
- Minor defects.

A defect is any non-conformance of the loudspeaker with its specified requirements.

A *major defect* is a defect that is likely to result in failure or to reduce materially the usability of the loudspeaker.

A *minor defect* is a defect that is not likely to reduce materially the usability of the loudspeaker, or is a departure from established standards having little bearing on the effective operation of the loudspeaker.

Main rules

All independent defects found during inspection must be used for quality evaluation. All epidemic defects must be taken into account.

When more defects appear from the same cause, only the most serious defect must be taken into account.

The evaluation must be within the limits of the specification of the loudspeaker and for unspecified characteristics be related to an approval model or limit samples.

Expression of non-conformance

The extent of non-conformance can be expressed in one or more figures:

- one major and one minor figure for visual and auditive inspection together.
- separate major and minor figures for visual inspection, auditive inspection and measurements.

Acceptability of lots or batches

The AQLs, inspection level(s) and batch sizes are selected according to the specific conditions of the Quality Agreement between supplier and customer.

GENERAL

Visual inspection (workmanship and appearance)

Defects concerning packaging, labelling, quantities and loose dirt or strange material between the loudspeakers are not classified but reported separately.

Incorrect type or not identifiable type.

(Partly) missing, incorrect or unreadable marking.

Missing piece-part.

Missing plating/coating.

Partly missing plating/coating, or corrosion.

Missing connection/joint (soldering, glueing, screwing, riveting, pinning, sealing).

Missing or double polarity marking; incorrect polarity indication.

Short-circuit or chance of short-circuit

Tag terminal having poor solderability or plugability

Mounting in application impossible by incorrect mechanical dimensions.

Dirt, stains, spots (glue, tin, ink, paint), incorrect plating/coating or damaging on car radio boxes or on that part of the loudspeaker which is visible in an open box.

Damaged or wrong piece-part, or incorrectly mounted piece part.

Incorrect or bad connection/joint (soldering, glueing, etc.).

Dirt, stains, spots (glue, tin, ink, paint) or incorrect plating/coating which is not visible in the application.

Auditive inspection

Inoperative or interruptions

Audible low level

Dissonance

Grating or rattling

Rustling

Shrilling

Distortion

	defects	
	major	minor
Incorrect type or not identifiable type.	X	
(Partly) missing, incorrect or unreadable marking.		X
Missing piece-part.	X	
Missing plating/coating.	X	
Partly missing plating/coating, or corrosion.		X
Missing connection/joint (soldering, glueing, screwing, riveting, pinning, sealing).	X	
Missing or double polarity marking; incorrect polarity indication.	X	
Short-circuit or chance of short-circuit	X	
Tag terminal having poor solderability or plugability	X	
Mounting in application impossible by incorrect mechanical dimensions.	X	
Dirt, stains, spots (glue, tin, ink, paint), incorrect plating/coating or damaging on car radio boxes or on that part of the loudspeaker which is visible in an open box.	X	X
Damaged or wrong piece-part, or incorrectly mounted piece part.	X	X
Incorrect or bad connection/joint (soldering, glueing, etc.).	X	X
Dirt, stains, spots (glue, tin, ink, paint) or incorrect plating/coating which is not visible in the application.		X
Inoperative or interruptions	X	
Audible low level	X	
Dissonance		
Grating or rattling	X	
Rustling	X	X
Shrilling	X	X
Distortion	X	X

procedure for inspection of loudspeakers

Measurements

(Only for loudspeakers in approved Hi-fi applications)

Resonance frequency

Deviation more than 30% from the nominal value.
Deviation outside the tolerance.

Voice coil resistance

Outside twice the tolerance.
Outside the tolerance.

Frequency response curve

Sensitivity:
Deviation more than 2 dB from the nominal value.

Shape:
Curve over a bandwidth more than one octave
outside the tolerance.
Curve over a bandwidth more than 1/3 octave
outside the tolerance.

Distortion

Outside the requirements according to DIN 45 500.

Incorrect polarity

P.H.C. test

Damaged piece-part, loose connection/joint or
any other defect mentioned under auditive in-
spection or measurements (except resonance
frequency) appeared at the life test in a
period of maximum 100 hours.

	defects	
	major	minor
	X	X
	X	X
	X	
	X	
		X
	X	
	X	
	X	





LOW POWER LOUDSPEAKERS



771027-11-21

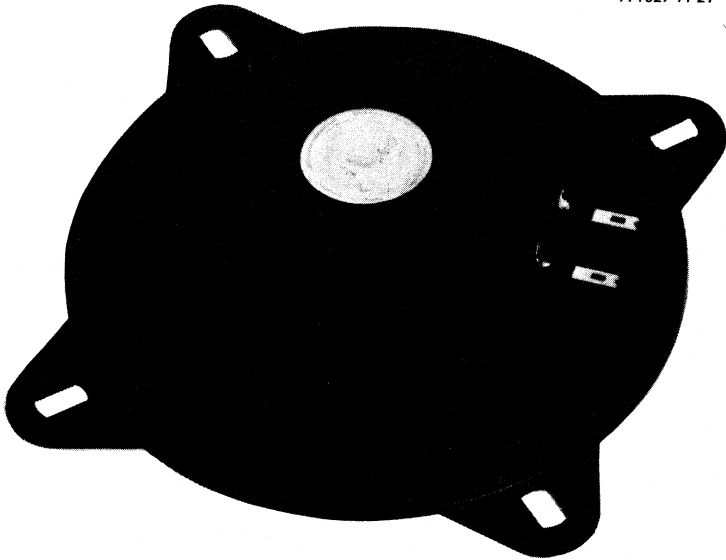

Type AD4472/X15



1¼ INCH LOW POWER LOUDSPEAKER

APPLICATION

The absence of magnetic stray field due to steel alloy sinterpot magnet system, makes this loudspeaker suitable for use in portables, intercoms and dictation equipment where very small dimensions are required.

TECHNICAL DATA

	version		
	Z8	Z15	Z25
Rated impedance	8	15	25 Ω
Voice coil resistance	7,1	13,5	19,8 Ω
Rated frequency range	300 to 7000		Hz
Resonance frequency	500		Hz
Power handling capacity, loudspeaker unmounted, measured without filter	300		mW
Operating power (sound level 74 dB, 0,5 m)	90		mW
Sweep voltage (frequency range: 400 to 15000 Hz)	1,1	1,5	1,9 V
Energy in air gap	5,3		mJ
Flux density	0,5		T
Air-gap height	2,5		mm
Voice coil height	1,5	2,1	2,3 mm
Core diameter	10		mm
Magnet material	steel alloy		
diameter	10		mm
mass	0,006		kg
Mass of loudspeaker	0,017		kg

The loudspeaker has a polycarbonate cone and surround. Connection to the loudspeaker by soldering.

Dimensions in mm

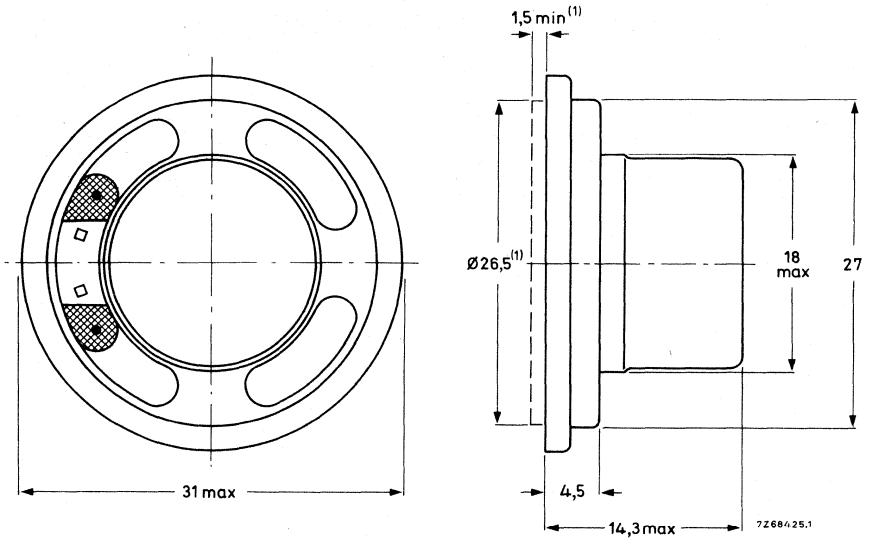

Fig. 1.

(1) Baffle hole and clearance depth required for cone movement at the specified power handling capacity.

→ One tag is indicated by a red mark for in-phase connection.

→ **AVAILABLE VERSIONS**

AD0198/Z25, catalogue number 2403 256 12121

AD0198/Z15, catalogue number 2403 256 12122

AD0198/Z8, catalogue number 2403 256 12123

these numbers apply to bulk packed loudspeakers, minimum packing quantity 228 per unit.

FREQUENCY RESPONSE CURVE (see Fig. 2)

Sound pressure measured in anechoic room, loudspeaker mounted on IEC baffle.

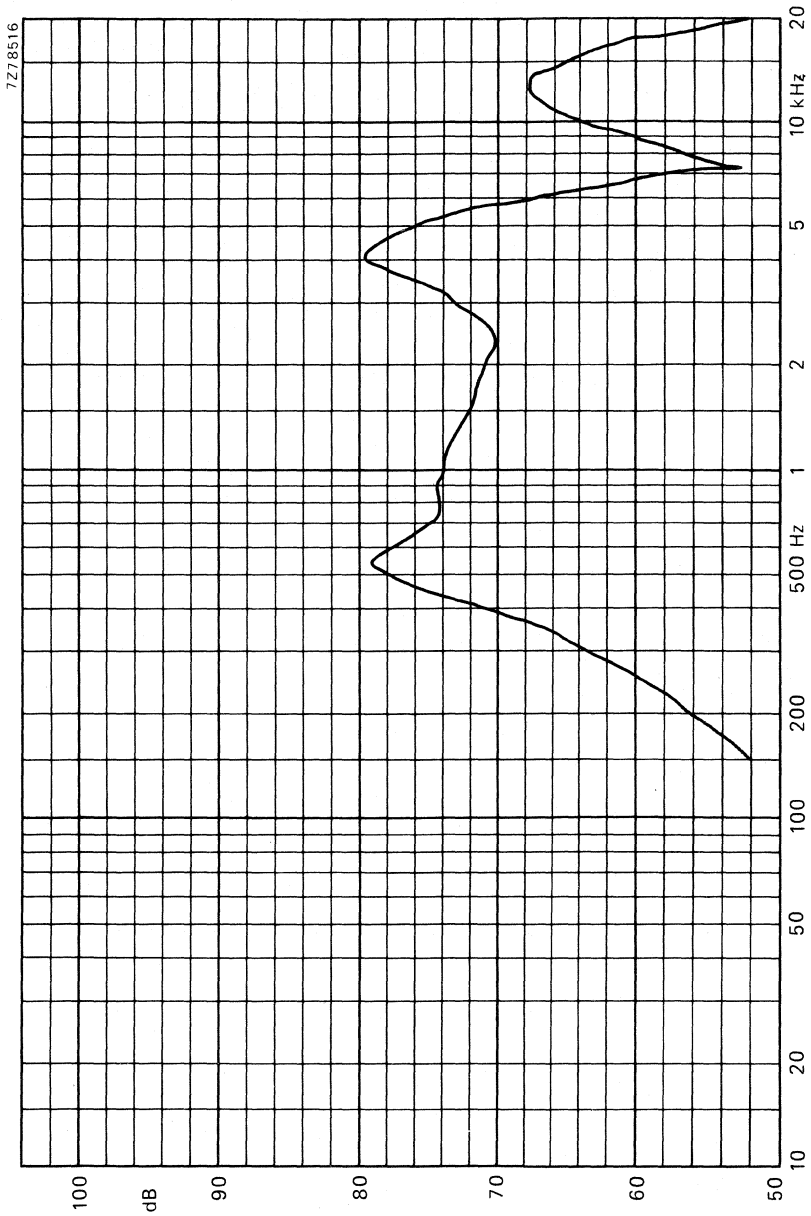

Fig. 2.



2½ INCH LOW POWER LOUDSPEAKER

APPLICATION

For portable receivers and intercoms.

TECHNICAL DATA

	version					
	Z4	Z8	Z15	Z25	Z50	Z150
Rated impedance	4	8	15	25	50	150 Ω
Voice coil resistance	3,5	7,1	13,7	22,8	37	127 Ω
Rated frequency range	180 to 4000					Hz
Resonance frequency	360					Hz
Power handling capacity, loudspeaker unmounted, measured without filter	1					W
Operating power (sound level 90 dB, 0,5 m)	0,55					W
Sweep voltage (frequency range: 240 to 15000 Hz)	1	1,4	1,9	2,5	5	8,7 V
Energy in air gap	12,7					mJ
Flux density	0,74					T
Air-gap height	2,5					mm
Voice coil height	2,7	2,2	3,0	3,6	3,9	3,5 mm
Core diameter	10					
Magnet material	ceramic					
diameter	28,5					mm
mass	0,018					kg
Mass of loudspeaker	0,05					kg

The loudspeaker has a plastic frame, and a paper cone and surround. Connection to the loudspeaker by means of 2,8 mm (0,11 inch) tag connectors or by soldering.

Dimensions (mm)

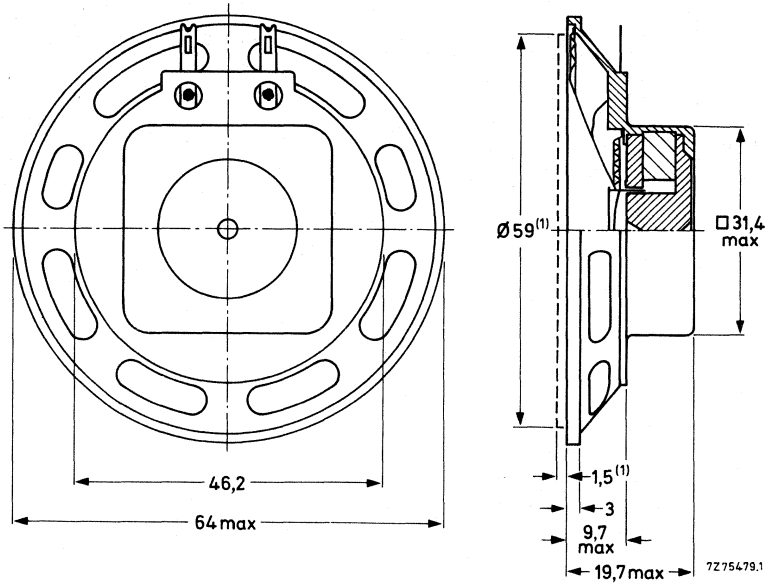

Fig. 1.

*Baffle hole and clearance depth required for cone movement at the specified power handling capacity.

One tag is indicated by + sign for in-phase connection.

AVAILABLE VERSIONS

- AD2071/Z4, catalogue number 2403 257 23821
- AD2071/Z8, catalogue number 2403 257 23822
- AD2071/Z15, catalogue number 2403 257 23823
- AD2071/Z25, catalogue number 2403 257 23824
- AD2071/Z50, catalogue number 2403 257 23826
- AD2071/Z150, catalogue number 2403 257 23825

these numbers apply to bulk packed loudspeakers, minimum packing quantity 125 per unit.

FREQUENCY RESPONSE CURVE (see Fig. 2)

Sound pressure measured in anechoic room, loudspeaker mounted on IEC baffle.

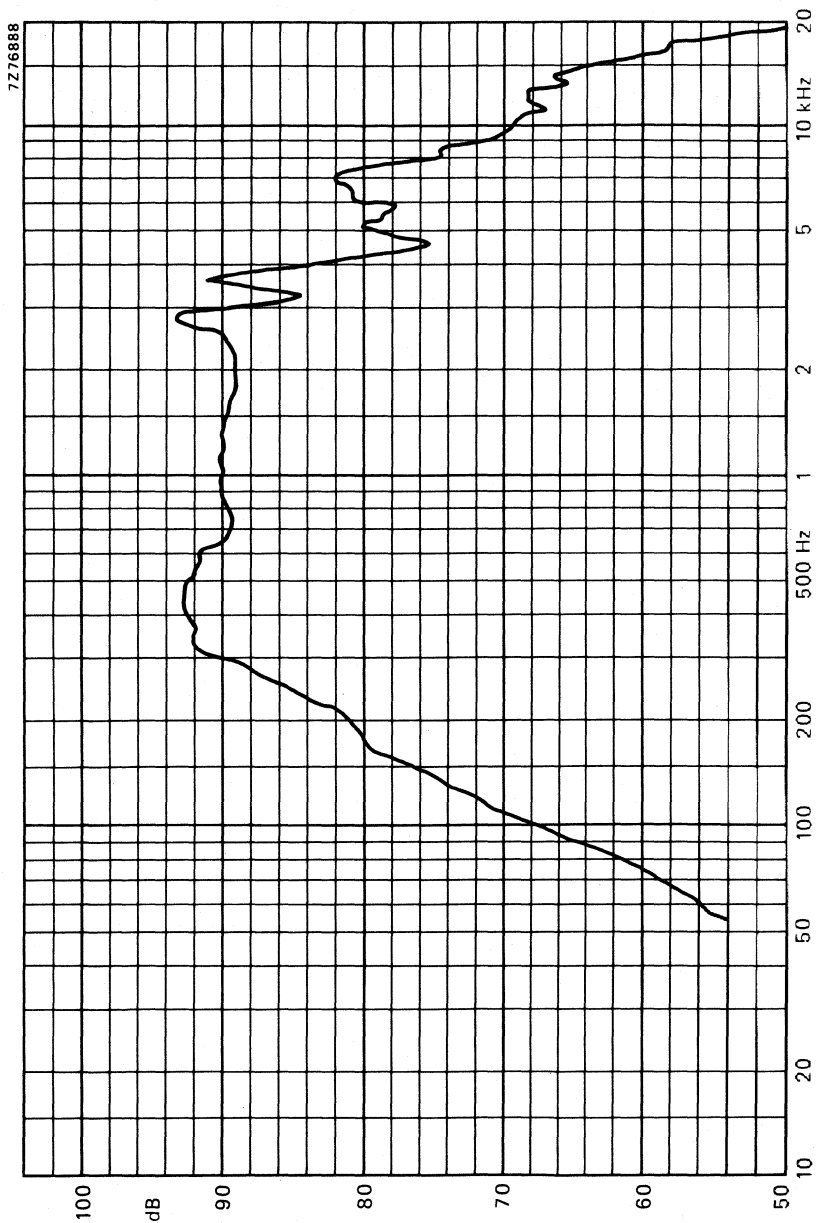

Fig.2.



2 INCH LOW POWER LOUDSPEAKER

APPLICATION

The absence of magnetic stray field due to steel alloy sinterpot magnet system, makes this loudspeaker suitable for use in portables, intercoms and dictation equipment where very small dimensions are required.

TECHNICAL DATA

	version		
	Z8	Z15	Z25
Rated impedance	8	15	25 Ω
Voice coil resistance	7,1	13,5	19,8 Ω
Rated frequency range	300 to 4000		Hz
Resonance frequency	420		Hz
Power handling capacity, loudspeaker unmounted, measured without filter	500		mW
Operating power (sound level 74 dB, 0,5 m)	37		mW ←
Sweep voltage (frequency range: 300 to 10 000 Hz)	1,4	1,9	2,5 V
Energy in air gap	5,3		mJ
Flux density	0,5		T
Air-gap height	2,5		mm
Voice coil height	1,7	2,1	2,3 mm
Core diameter	10		mm
Magnet material	steel alloy		
diameter	10		mm
mass	0,006		kg.
Mass of loudspeaker	0,021		kg

The loudspeaker has a paper cone and surround. Connection to the loudspeaker by soldering.

Dimensions in mm

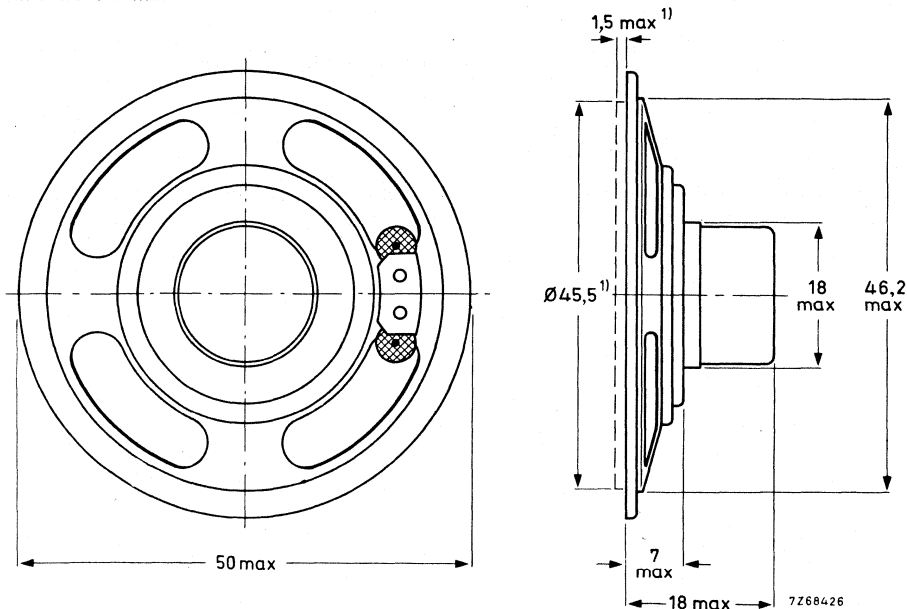

Fig. 1.

(1) Baffle hole and clearance depth required for cone movement at the specified power handling capacity.

One tag is indicated by a red mark for in-phase connection.

AVAILABLE VERSIONS

AD2099/Z25, catalogue number 2422 256 22221

AD2099/Z15, catalogue number 2422 256 22222

AD2099/Z8, catalogue number 2422 256 22223

} these numbers apply to bulk packed loudspeakers, minimum packing quantity 100 per unit.

FREQUENCY RESPONSE CURVE (Fig. 2)

Sound pressure measured in anechoic room, loudspeaker mounted on IEC baffle. Above 1000 Hz the sensitivity may be, over the width of one octave, maximum 2 dB lower than indicated. Input power 50 mW.

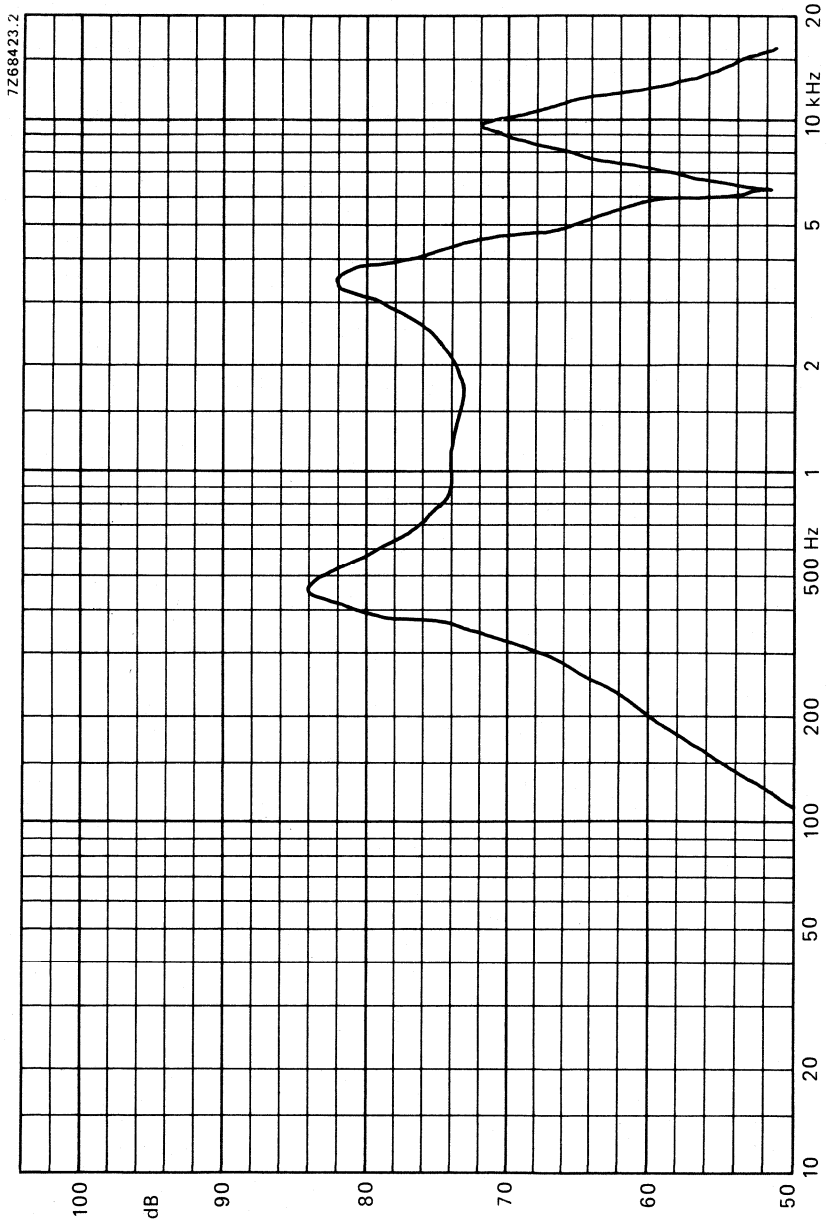

Fig. 2.



3 INCH LOW POWER LOUDSPEAKERS

APPLICATION

For portable receivers and intercoms.

TECHNICAL DATA

	version					
	Y4	Y8	Y15	Y25	Y50	Y150
Rated impedance	4	8	15	25	50	150 Ω
Voice coil resistance	3,5	7,1	13,7	22,8	45	127 Ω
Rated frequency range	100 to 6000					Hz
Resonance frequency	250					Hz
Power handling capacity, loudspeaker unmounted, measured without filter	2					W
Operating power (sound level 90 dB, 0,5 m)	0,6					W ←
Sweep voltage (frequency range 170 to 15 000 Hz)	2	2,8	3,9	5	7,1	12,2 V ←
Energy in air gap	12,7					mJ
Flux density	0,74					T
Air-gap height	2,5					mm
Voice coil height	2,7	2,2	3,0	3,6	4,7	3,5 mm
Core diameter	10					mm
Magnet material	ceramic					
diameter	28,5					mm ←
mass	0,018					kg
Mass of loudspeaker	0,059					kg

The loudspeakers have a plastic frame, and a paper cone and surround. Type AD3371/Y. is provided with 4 mounting ears (dotted in Fig. 1). Connection to the loudspeakers by means of 2,8 mm (0,11 inch) tag connectors or by soldering.

AD3071/Y.
AD3371/Y.

Dimensions in mm

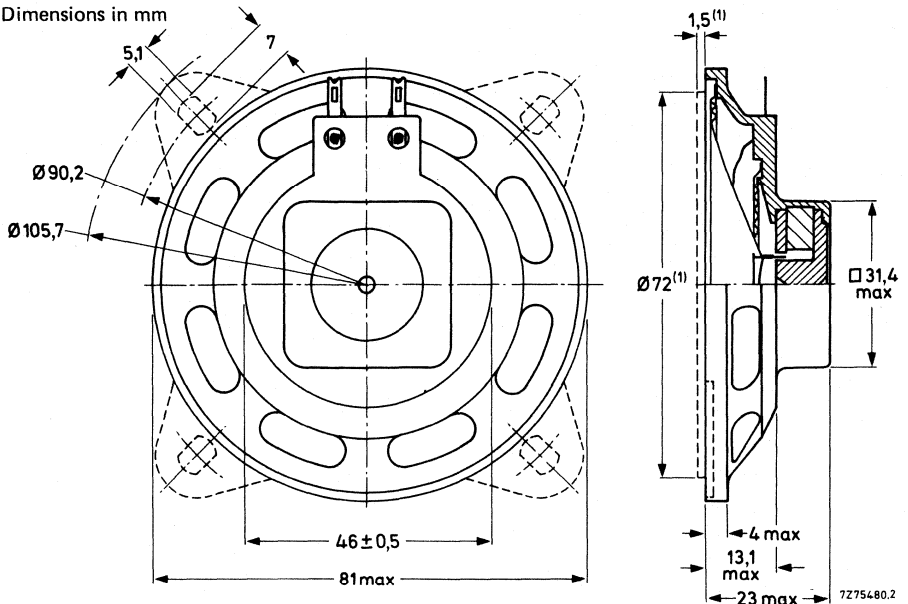

Fig. 1 Dotted mounting ears for type AD3371/Y.

(1) Baffle hole and clearance depth required for cone movement at the specified power handling capacity.

One tag is indicated by a red mark for in-phase connection.

→ AVAILABLE VERSIONS

AD3071/Y4,	catalogue number 2403 257 23621
AD3071/Y8,	catalogue number 2403 257 23622
AD3071/Y15,	catalogue number 2403 257 23623
AD3071/Y25,	catalogue number 2403 257 23624
AD3071/Y50,	catalogue number 2403 257 23625
AD3071/Y150,	catalogue number 2403 257 23626
AD3371/Y4,	catalogue number 2403 257 23521
AD3371/Y8,	catalogue number 2403 257 23522
AD3371/Y15,	catalogue number 2403 257 23523
AD3371/Y25,	catalogue number 2403 257 23524
AD3371/Y50,	catalogue number 2403 257 23525
AD3371/Y150,	catalogue number 2403 257 23526

these numbers apply to bulk packed loudspeakers, minimum packing quantity 50 per unit.

FREQUENCY RESPONSE CURVE (see Fig. 2)

Sound pressure measured in anechoic room, loudspeaker mounted on IEC baffle.

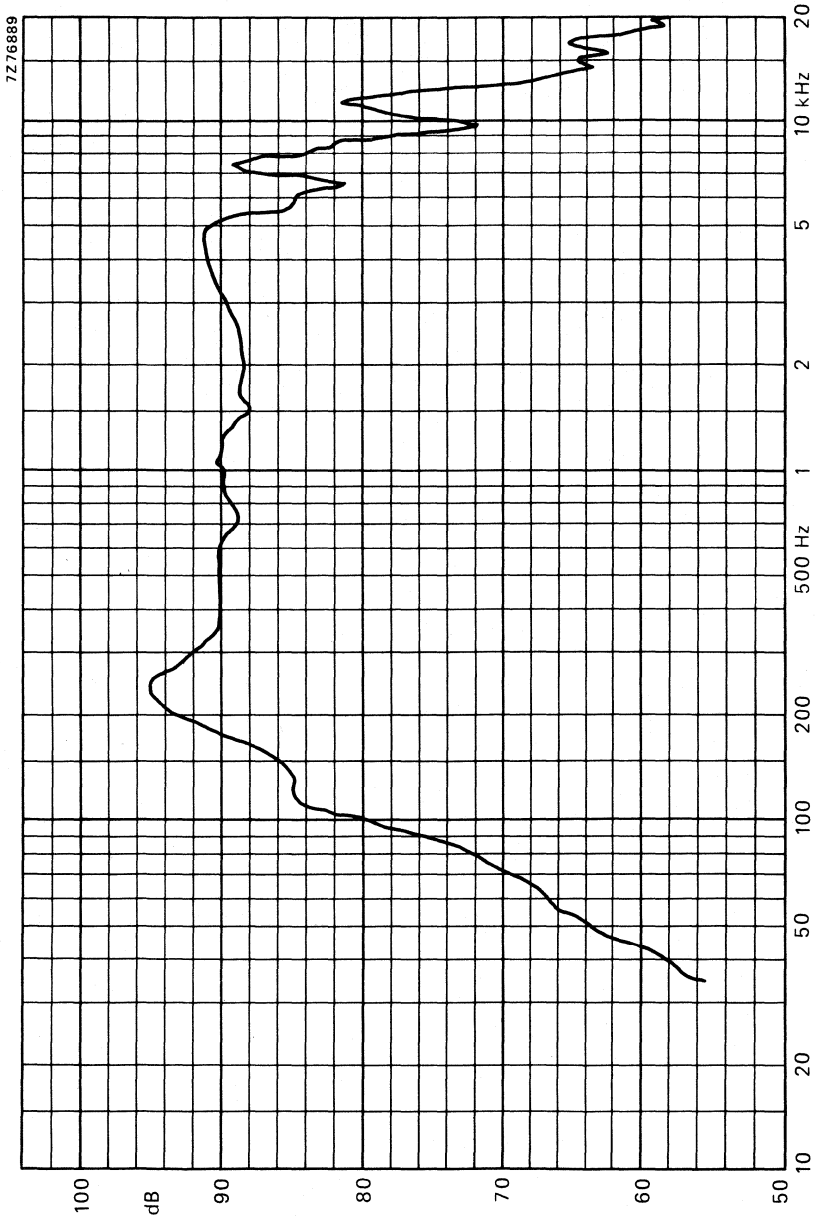

Fig. 2.



4 INCH LOW POWER LOUDSPEAKERS

APPLICATION

For portable receivers and intercoms.

TECHNICAL DATA

	version			
	X4	X8	X15	X25
Rated impedance	4	8	15	25 Ω
Voice coil resistance	3,5	7,1	13,7	22,8 Ω
Rated frequency range	80 to 15 000			Hz
Resonance frequency	170			Hz
Power handling capacity, loudspeaker unmounted, measured without filter	3			W
Operating power (sound level 90 dB, 0,5 m)	0,45			W
Sweep voltage (frequency range 100 to 20 000 Hz)	2,4	3,5	4,7	6,1 V
Energy in air gap	12,7			mJ
Flux density	0,74			T
Air-gap height	2,5			mm
Voice coil height	2,7	2,2	3,0	3,6 mm
Core diameter	10			mm
Magnet material	ceramic			
diameter	28,5			mm
mass	0,018			kg
Mass of loudspeaker, round flange version	0,067			kg
square flange version	0,069			kg

The loudspeakers have a plastic frame, and a paper cone and surround. Connection to the loudspeakers is by means of 2,8 mm (0,11 inch) tag connectors or soldering.

AD4072/X.
AD4472/X.

Dimensions in mm

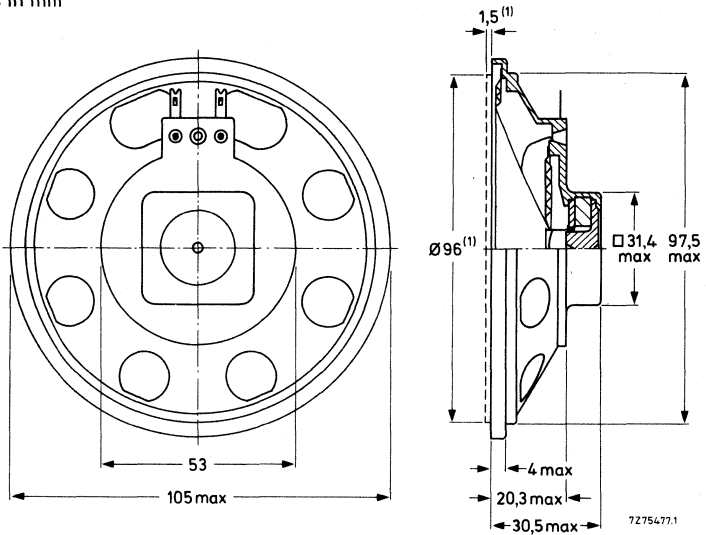

Fig. 1a.

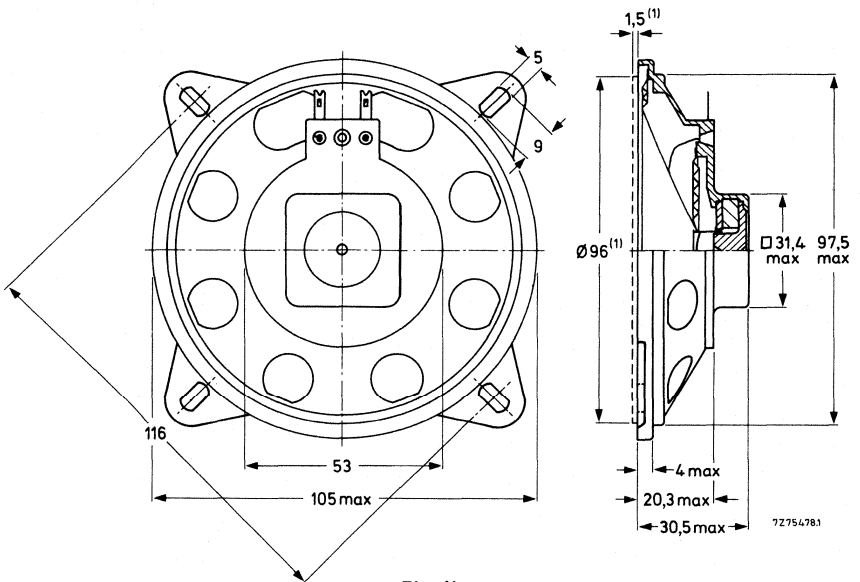

Fig. 1b.

(1) Baffle hole and clearance depth required for cone movement at the specified power handling capacity.

One tag is indicated by a red mark for in-phase connection.

► AVAILABLE VERSIONS

type according to Fig. 1a.

AD4072/X4, catalogue number 2403 257 24225

AD4072/X8, catalogue number 2403 257 24226

AD4072/X15, catalogue number 2403 257 24227

AD4072/X25, catalogue number 2403 257 24228

type according to Fig. 1b.

AD4472/X4, catalogue number 2403 257 24825

AD4472/X8, catalogue number 2403 257 24826

AD4472/X15, catalogue number 2403 257 24827

AD4472/X25, catalogue number 2403 257 24828

these numbers apply to bulk
packed loudspeakers, minimum
packing quantity 50 per unit.

FREQUENCY RESPONSE CURVE (see Fig.2)

Sound pressure measured in anechoic room, loudspeaker mounted on IEC baffle.



AD4072/X.
AD4472/X.

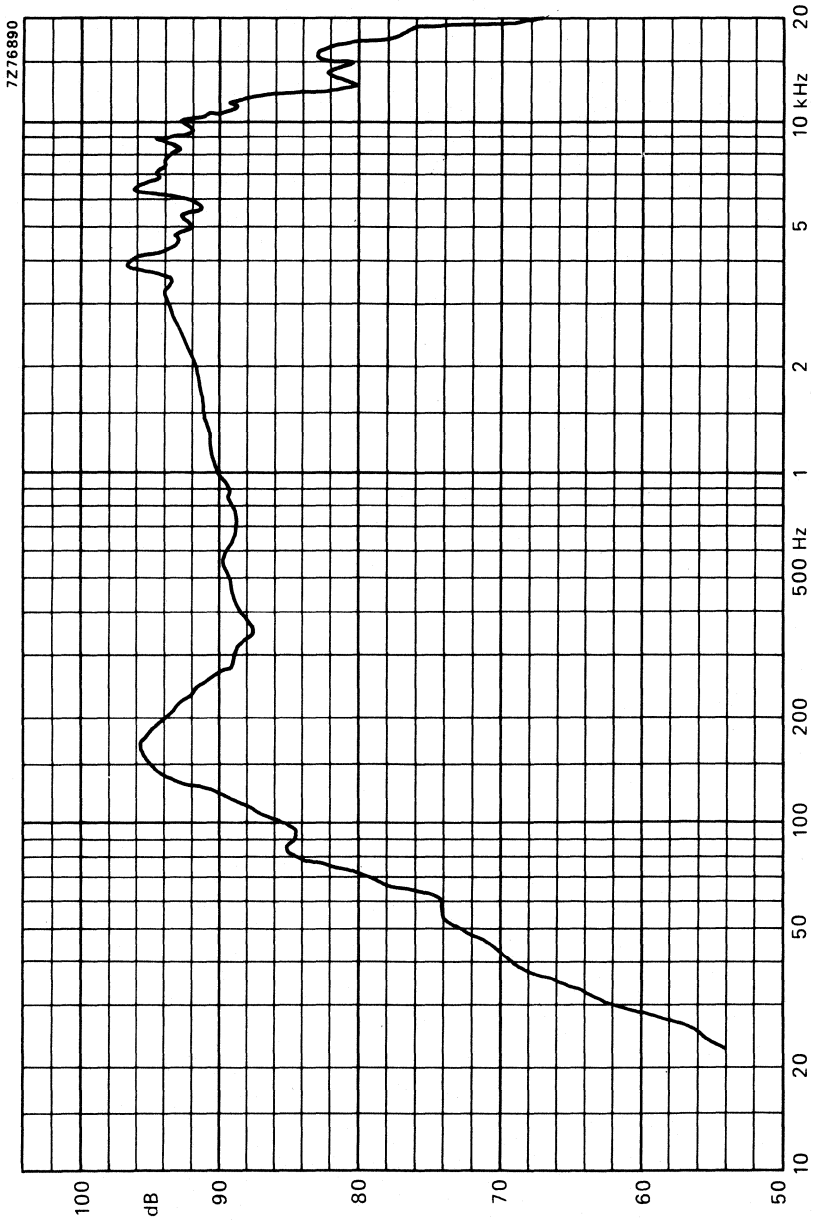

Fig.2.

4 INCH LOW POWER LOUDSPEAKERS

APPLICATION

Very suitable for portable black and white, and colour television sets, because these loudspeakers are provided with a magnetic shield.

TECHNICAL DATA

	version			
	X4	X8	X15	X25
Rated impedance	4	8	15	25 Ω
Voice coil resistance	3,5	7,1	13,7	22,8 Ω
Rated frequency range	80 to 15 000			Hz
Resonance frequency	170			Hz
Power handling capacity, loudspeaker unmounted, measured without filter	2,5			W
Operating power (sound level 90 dB, 0,5 m)	0,18			W
Sweep voltage (frequency range 100 to 20 000 Hz)	2,4	3,5	4,7	6,1 V
Energy in air gap	12,7			mJ
Flux density	0,74			T
Air-gap height	2,5			mm
Voice coil height	2,7	2,2	3,0	3,6 mm
Core diameter	10			mm
Magnet material	ceramic			
diameter	31			mm
mass	0,02			kg
Mass of loudspeaker,				
round flange version	0,067			kg
square flange version	0,069			kg

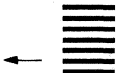

The loudspeakers have a plastic frame, and a paper cone and surround. Connection to the loudspeakers is by means of 2,8 mm (0,11 inch) tag connectors or soldering.

AD4074/X.
AD4474/X.

Dimensions (mm)

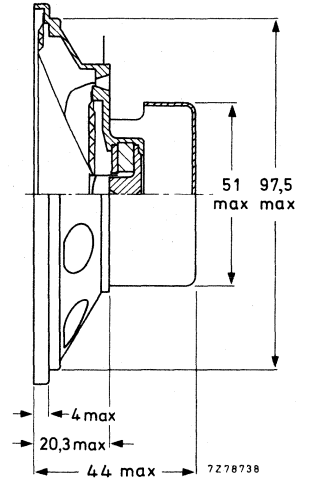
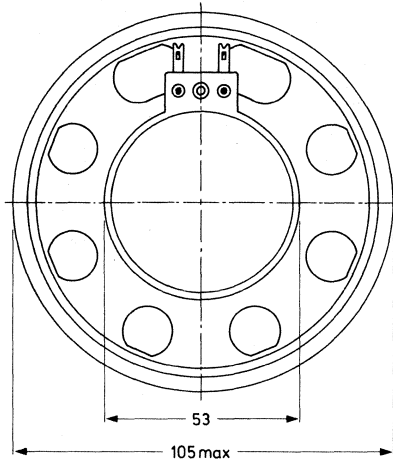

Fig. 1a.

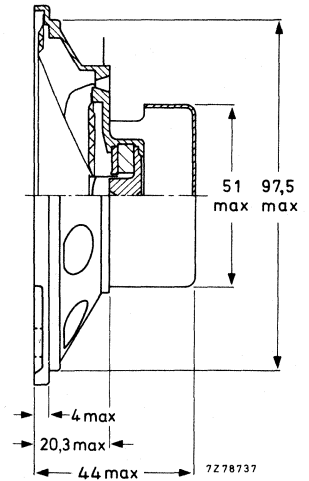
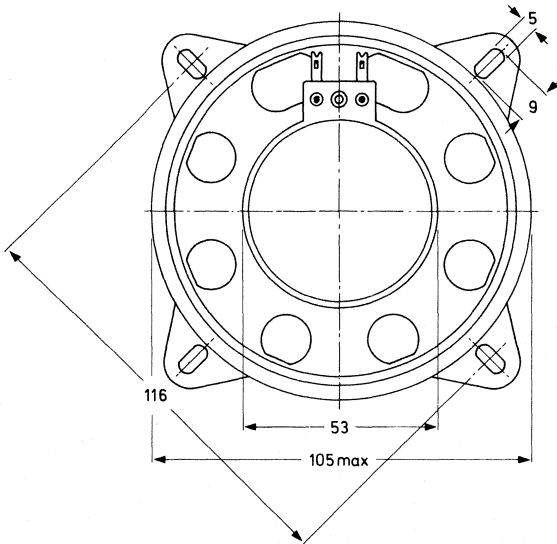

Fig. 1b.

One tag is indicated by a red mark for in-phase connection.

AVAILABLE VERSIONS



type according to Fig. 1a.

- AD4074/X4, catalogue number 2403 257 24325
- AD4074/X8, catalogue number 2403 257 24326
- AD4074/X15, catalogue number 2403 257 24327
- AD4074/X25, catalogue number 2403 257 24328

type according to Fig. 1b.

- AD4474/X4, catalogue number 2403 257 24725
- AD4474/X8, catalogue number 2403 257 24726
- AD4474/X15, catalogue number 2403 257 24727
- AD4474/X25, catalogue number 2403 257 24728

these numbers apply to bulk
packed loudspeakers, minimum
packing quantity 40 per unit.

FREQUENCY RESPONSE CURVE (see Fig. 2)

Sound pressure measured in anechoic room, loudspeaker mounted on IEC baffle.



AD4074/X.
AD4474/X.

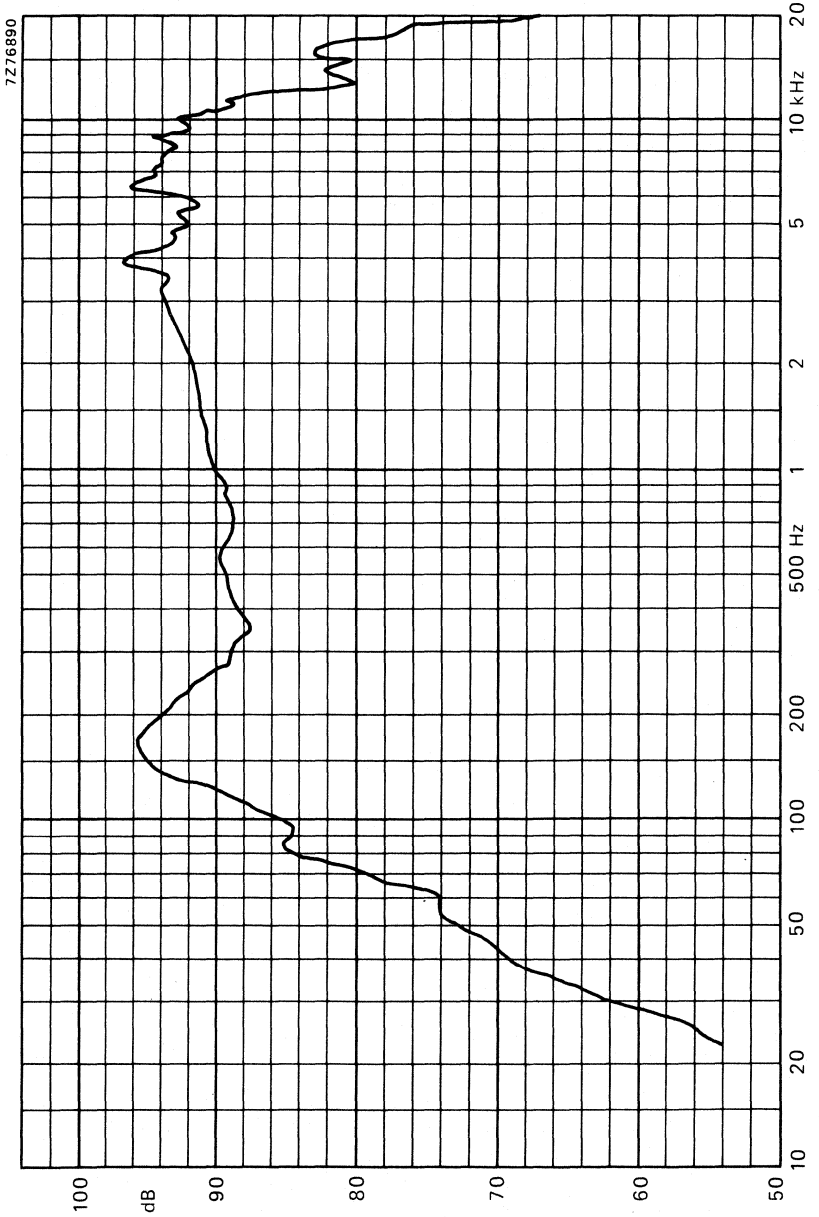
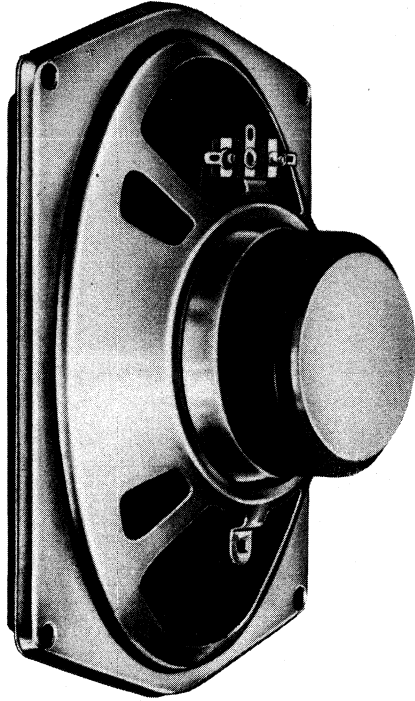

Fig. 2.

MEDIUM POWER LOUDSPEAKERS



721010-26-06



Type AD4681/X4



3 INCH MEDIUM POWER LOUDSPEAKERS

APPLICATION

Mainly for use with car radios.

TECHNICAL DATA

Rated impedance	4 Ω
Voice coil resistance	3,4 Ω
Rated frequency range	100 to 12 000 Hz
Resonance frequency	170 Hz
Power handling capacity, measured without filter unmounted	6 W
Operating power (sound level 90 dB, 1 m)	1,2 W
Sweep voltage, frequency range: 70 to 20 000 Hz	3,5 V
Energy in air gap	55 mJ
Flux density	1 T
Air-gap height	3 mm
Voice coil height	4,4 mm
Core diameter	18 mm
Magnet material	ceramic
diameter	53 mm
mass	0,1 kg
Mass of loudspeaker	0,22 kg

The loudspeakers have a paper dual cone and a textile surround. Connection to the loudspeakers by means of tag connectors or by soldering.



AD3080/M4
AD3380/M4

Dimensions in mm

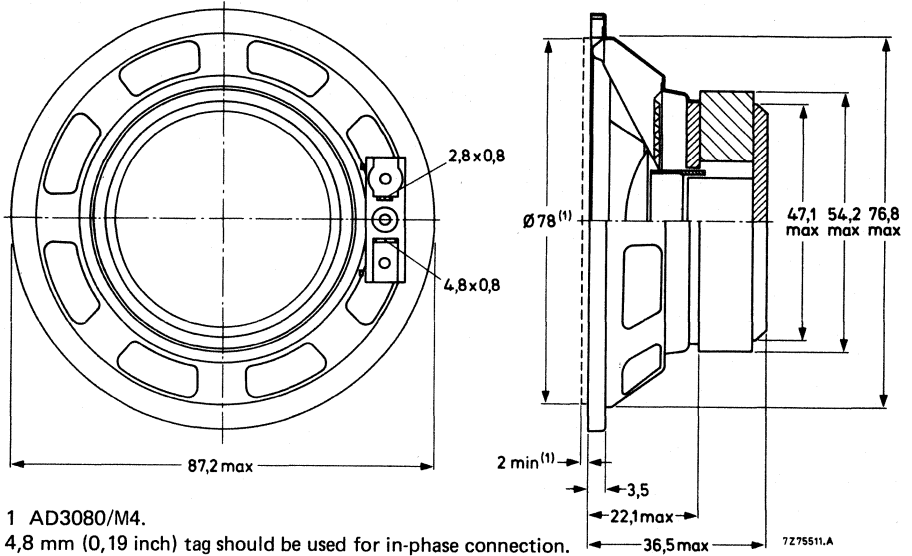

Fig. 1 AD3080/M4.
The 4,8 mm (0,19 inch) tag should be used for in-phase connection.

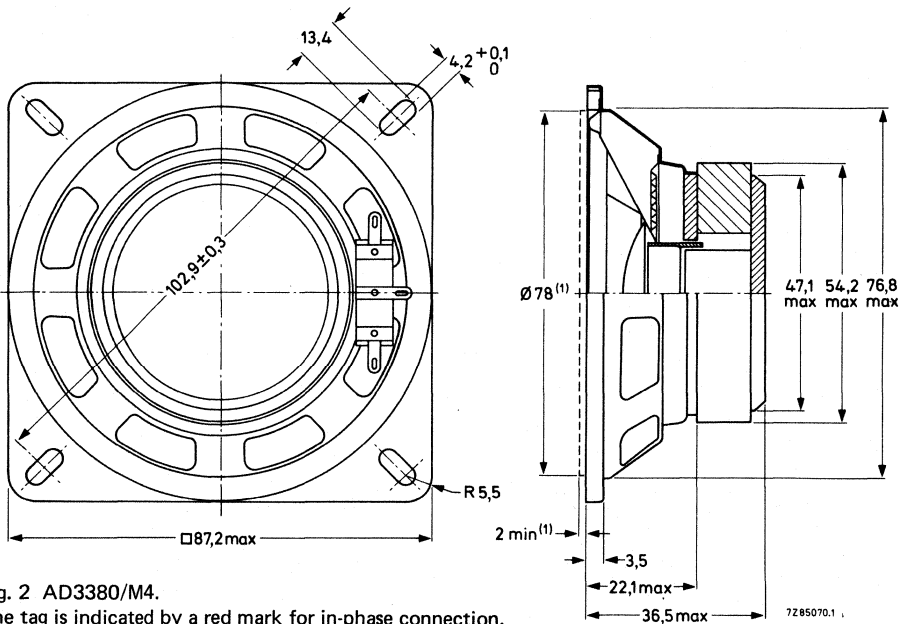

Fig. 2 AD3380/M4.
One tag is indicated by a red mark for in-phase connection.

(1) Baffle hole and clearance depth required for cone movement at the specified power handling capacity.

AVAILABLE VERSIONS

AD3080/M4	catalogue number 2422 257 34537
AD3380/M4	catalogue number 2422 257 34521

} these numbers apply to bulk-packed
loudspeakers, minimum packing
quantity 45 per unit. ←

FREQUENCY RESPONSE CURVES (see Fig. 3)

Measured in anechoic room at the operating power, loudspeaker mounted on IEC baffle.

Curve a: Sound pressure.

Curves d2 and d3: 2nd and 3rd harmonic distortion.



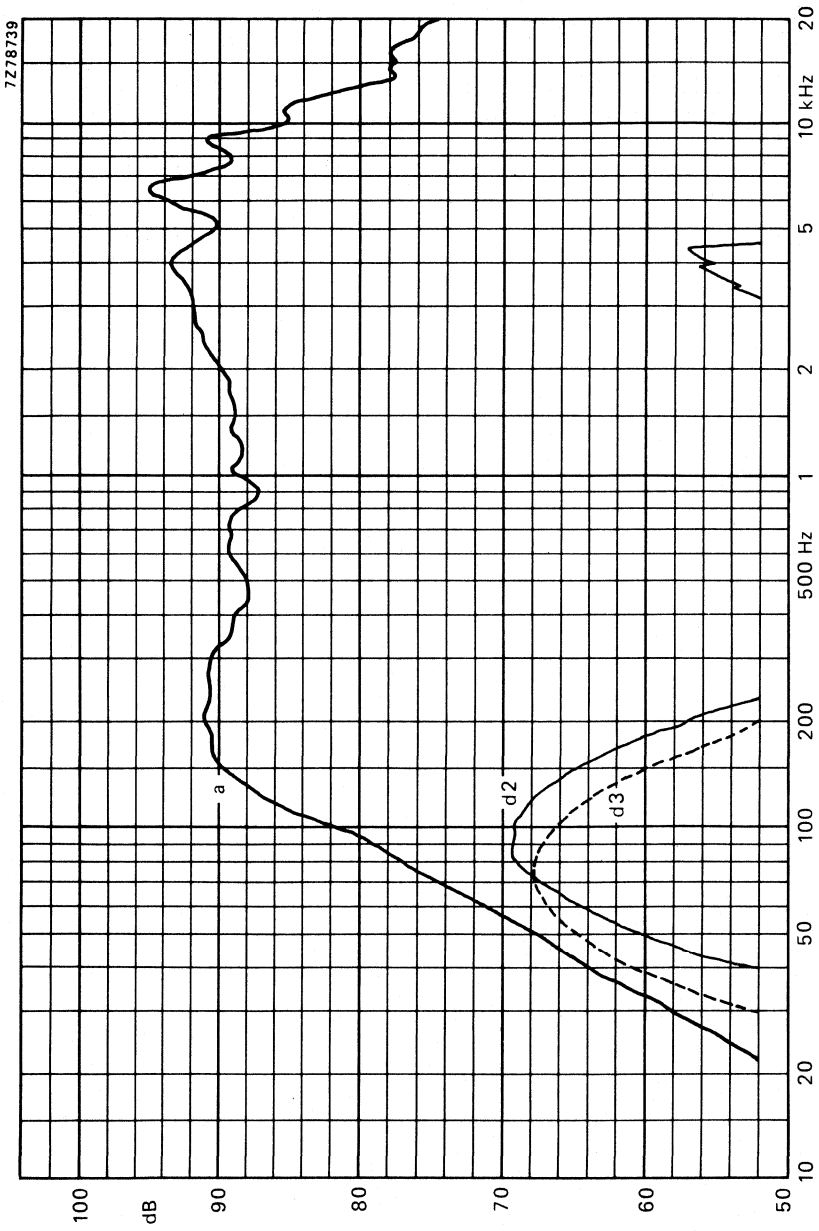

Fig. 3.



3 INCH MEDIUM POWER LOUDSPEAKER

APPLICATION

Mainly for use with car radios.

TECHNICAL DATA

Rated impedance	4 Ω
Voice coil resistance	3,4 Ω
Rated frequency range	35 to 15 000 Hz
Resonance frequency	85 Hz
Power handling capacity, measured without filter unmounted	6 W
mounted in 1 l sealed enclosure	10 W
Operating power (sound level 90 dB, 1 m)	2,5 W
Sweep voltage, frequency range: 45 to 20 000 Hz	3,5 V
Energy in air gap	55 mJ
Flux density	1 T
Air-gap height	3 mm
Voice coil height	4,4 mm
Core diameter	18 mm
Magnet material	ceramic
diameter	53 mm
mass	0,1 kg
Mass of loudspeaker	0,22 kg

The loudspeaker has a paper cone and a textile surround. Connection to the loudspeaker by means of a 4,8 mm (0,19 inch) and a 2,8 mm (0,11 inch) tag connector or by soldering.

Dimensions in mm

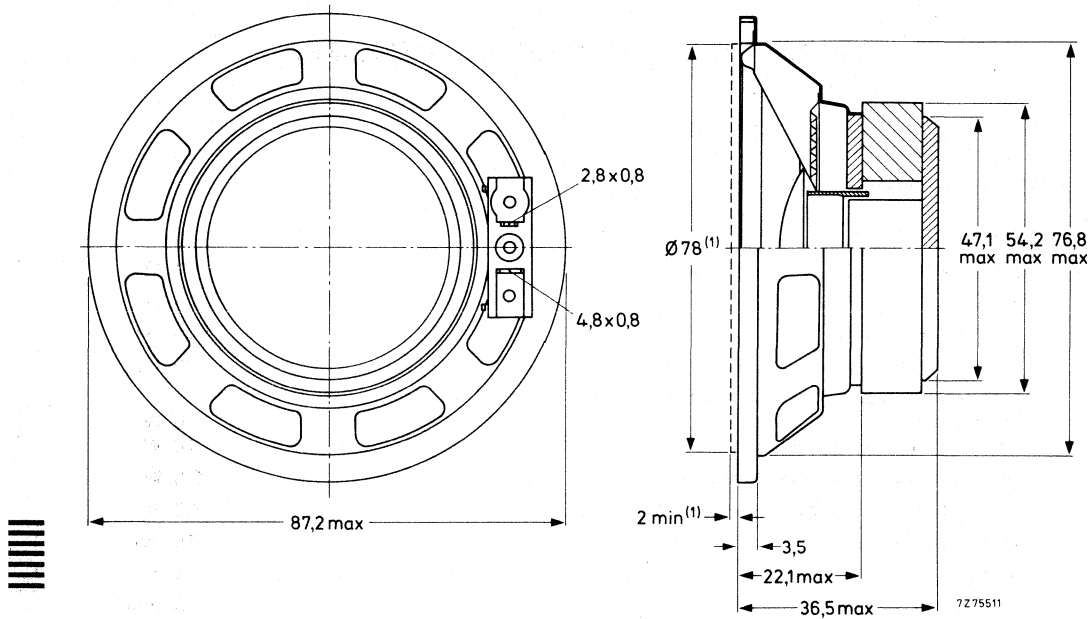

Fig. 1.

(1) Baffle hole and clearance depth required for cone movement at the specified power handling capacity.

→ The 4,8 mm (0,19 inch) tag should be used for in-phase connection.

→ **AVAILABLE VERSION**

AD 3080/X4 catalogue number 2422 257 34539, this number applies to bulk-packed loudspeakers, minimum packing quantity 45 per unit.

FREQUENCY RESPONSE CURVES (see Fig. 2)

Measured in anechoic room at the operating power. Loudspeaker front mounted on IEC baffle.

Curve a: Sound pressure.

Curves d2 and d3: 2nd and 3rd harmonic distortion.

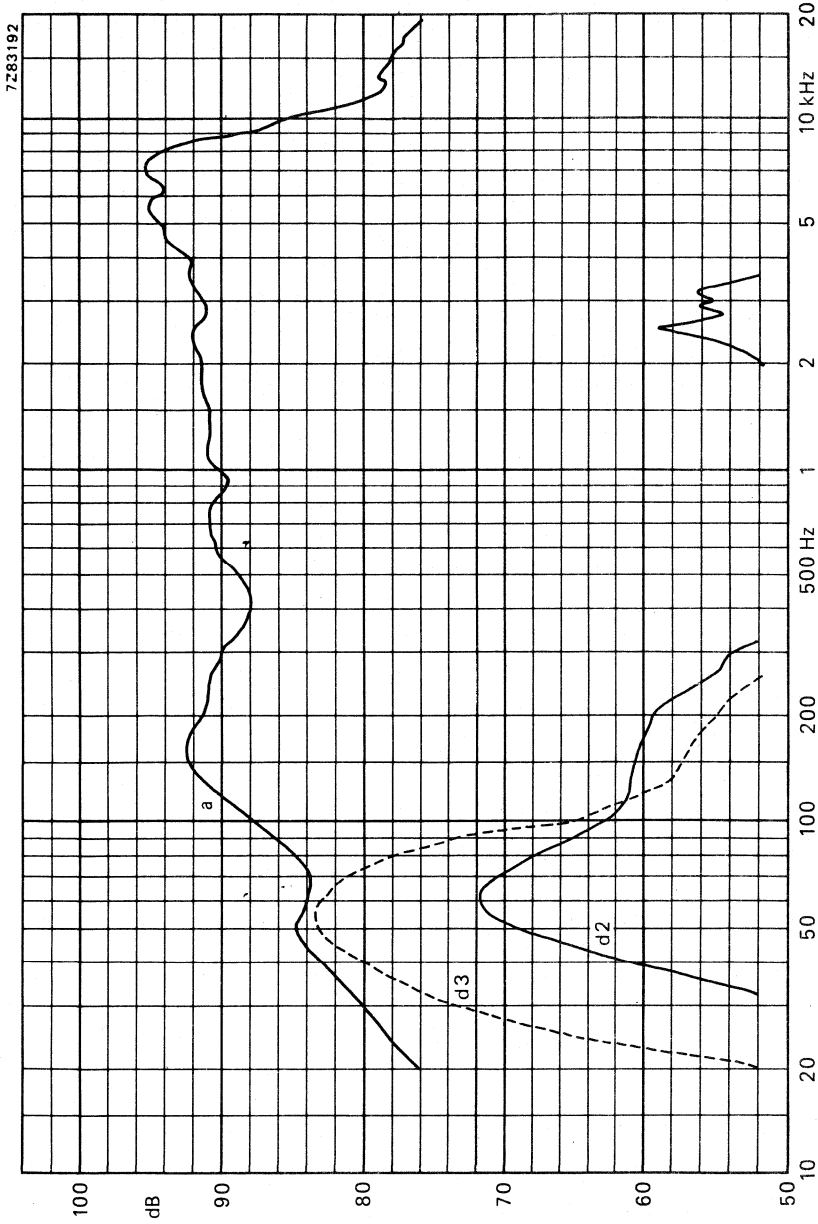

Fig. 2.



3 x 5 INCH MEDIUM POWER LOUDSPEAKER

APPLICATION

For use in portable radios, tape recorders and, due to absence of stray magnetic field, this loudspeaker can also be used in television sets. High sensitivity.

TECHNICAL DATA

	version				
	X4	X8	X15	X25	
Rated impedance	4	8	15	25	Ω
Voice coil resistance	3,4	7,1	13,5	22,5	Ω
Rated frequency range	90 to 15000				Hz
Resonance frequency	180				Hz
Power handling capacity, measured without filter, loudspeaker unmounted	3				W
Operating power (sound level 90 dB, 1 m)	1,5				W
Sweep voltage, frequency range: 80 to 20 000 Hz	2,5	3,5	4,7	6,2	V
Energy in air gap	20,5				mJ
Flux density	0,77				T
Air-gap height	2,5				mm
Voice coil height	3,5	4,2	2,7	3,3	mm
Core diameter	14,5				mm
Magnet material	steel alloy				
diameter	14,5				mm
mass	0,013				kg
Mass of loudspeaker	0,13				kg

The loudspeaker has a paper cone and surround. Connection to the loudspeaker by means of 2,8 mm (0,11 inch) tag connectors or by soldering.

Dimensions (mm)

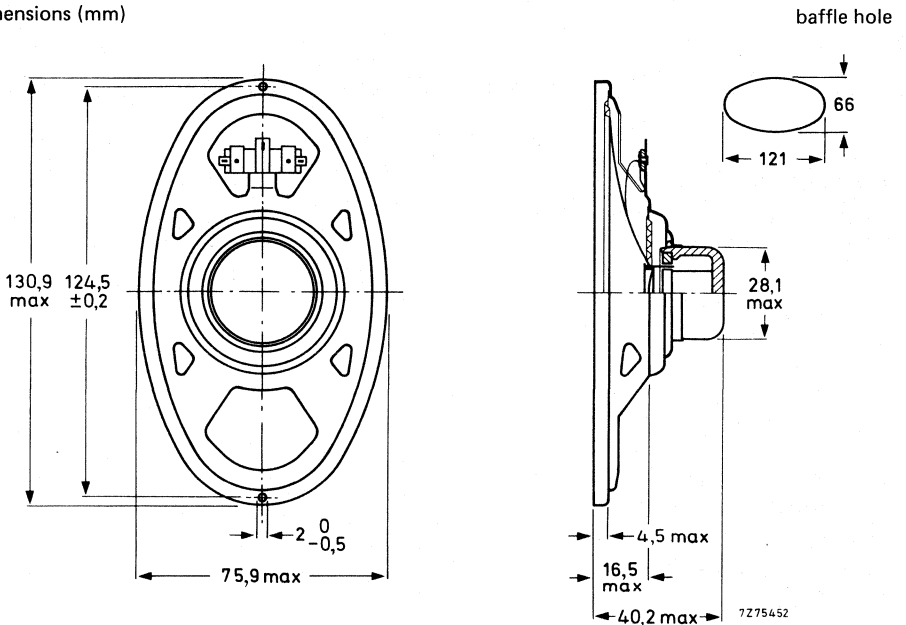

Fig. 1.

One tag is indicated by a red mark for in-phase connection.

→ AVAILABLE VERSION

- AD3595/X4, catalogue number 2422 256 30331
- AD3595/X8, catalogue number 2422 256 30332
- AD3595/X15, catalogue number 2422 256 30333
- AD3595/X25, catalogue number 2422 256 30334

} these numbers apply to bulk packed loudspeakers, minimum packing quantity 120 per unit.

FREQUENCY RESPONSE CURVES (see Fig. 2)

Curve a: Sound pressure.

Curves d2 and d3: 2nd and 3rd harmonic distortion, measured at the operating power of 1,5 W.

The curves are measured in anechoic room, loudspeaker mounted on IEC baffle.

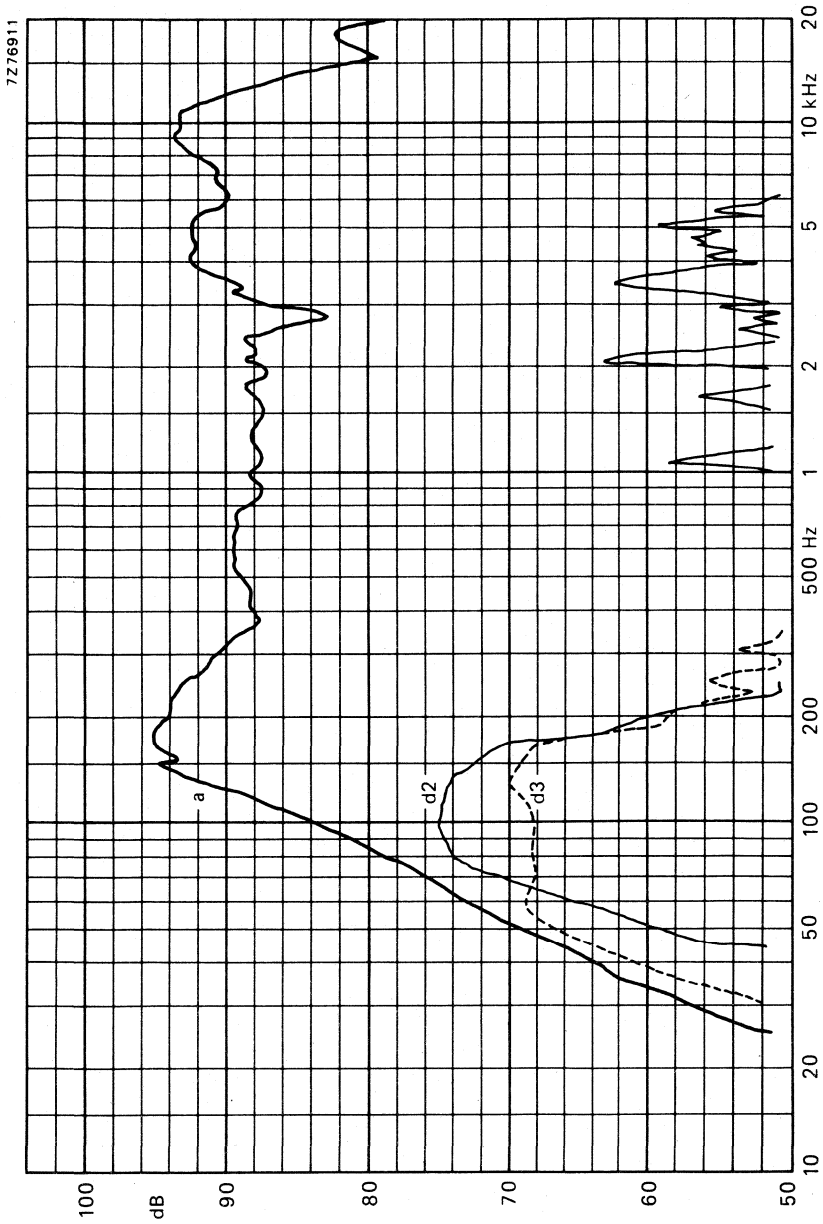

Fig. 2.



4 INCH MEDIUM POWER LOUDSPEAKER

APPLICATION

For audio equipment in general. Frequency response up to 14 kHz, high sensitivity in bass region.

TECHNICAL DATA

	version			
	X4	X8	X15	
Rated impedance	4	8	15	Ω
Voice coil resistance	3,4	7,1	13,5	Ω
Rated frequency range	80 to 14 000			Hz
Resonance frequency	150			Hz
Power handling capacity, measured without filter, loudspeaker unmounted	3			W
Operating power (sound level 90 dB, 1 m)	0,7			W
Sweep voltage (75 to 20 000 Hz)	2,5	3,5	4,7	V
Energy in air gap	38			mJ
Flux density	1,1			T
Air-gap height	2,5			mm
Voice coil height	3,5	4,1	2,7	mm
Core diameter	14			mm
Magnet material	ceramic			
diameter	46			mm
mass	0,053			kg
Mass of loudspeaker	0,16			kg

The loudspeaker has a paper cone and surround. Connection to the loudspeaker by means of 2,8 mm (0,11 inch) tag connectors or by soldering.



AD4085/X.
AD4485/X.

Dimensions (mm)

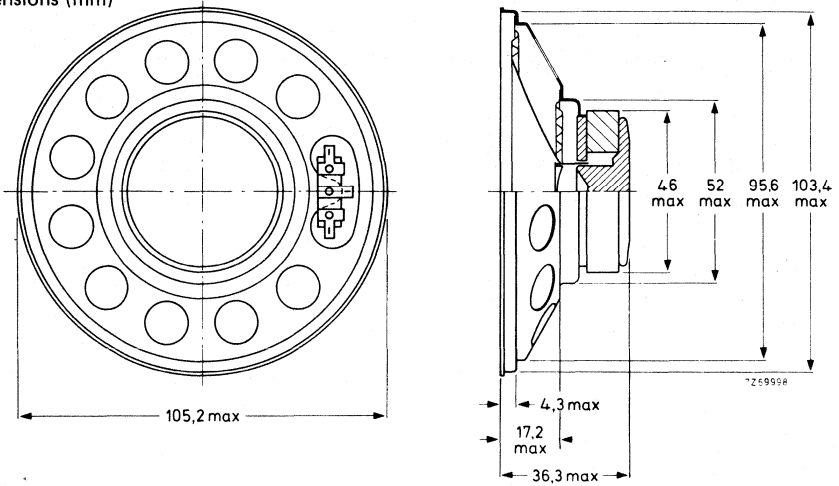

Fig. 1a Round flange type AD4085/X.

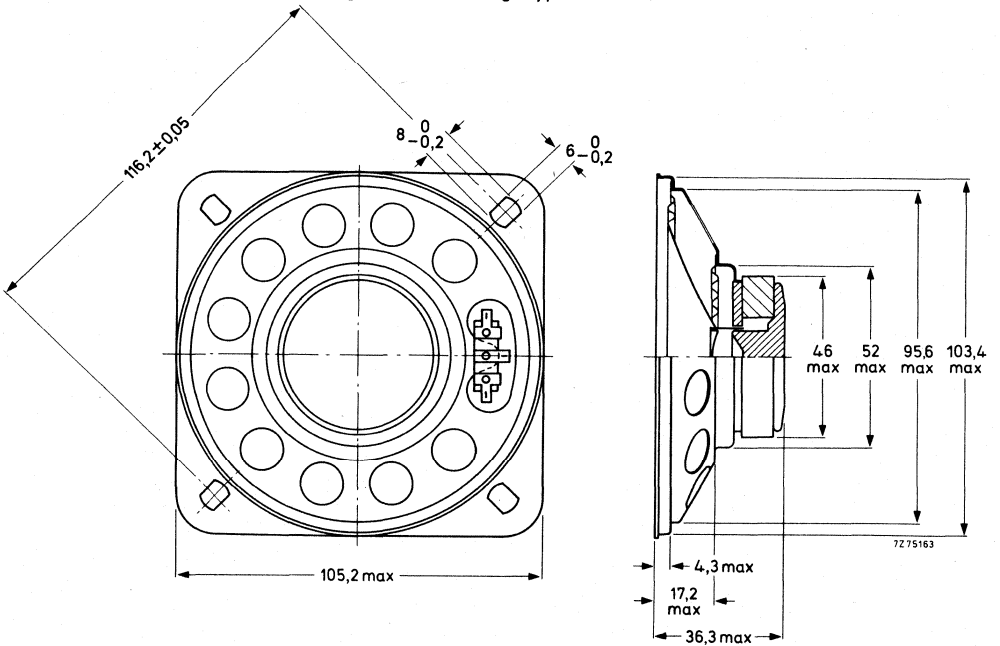

Fig. 1b Square flange type AD4485/X.

Baffle hole diameter 96 mm.

One tag is indicated by a red mark for in-phase connection.

→ **AVAILABLE VERSIONS**

Round flange type

AD4085/X4, catalogue number 2422 257 24321

AD4085/X8, catalogue number 2422 257 24322

AD4085/X15, catalogue number 2422 257 24323

Square flange type

AD4485/X4, catalogue number 2422 257 24331

AD4485/X8, catalogue number 2422 257 24332

AD4485/X15, catalogue number 2422 257 24333

these numbers apply to bulk
packed loudspeakers, minimum
packing quantity 108 per unit.

FREQUENCY RESPONSE CURVES (see Fig. 2)

Curve b: Sound pressure measured in anechoic room, loudspeaker mounted on baffle according to IEC 268-5, par. 4.4.

Curve c: 2nd and 3rd harmonic distortion measured at the operating power of 0,6 W in anechoic room. Loudspeaker front mounted on IEC baffle.



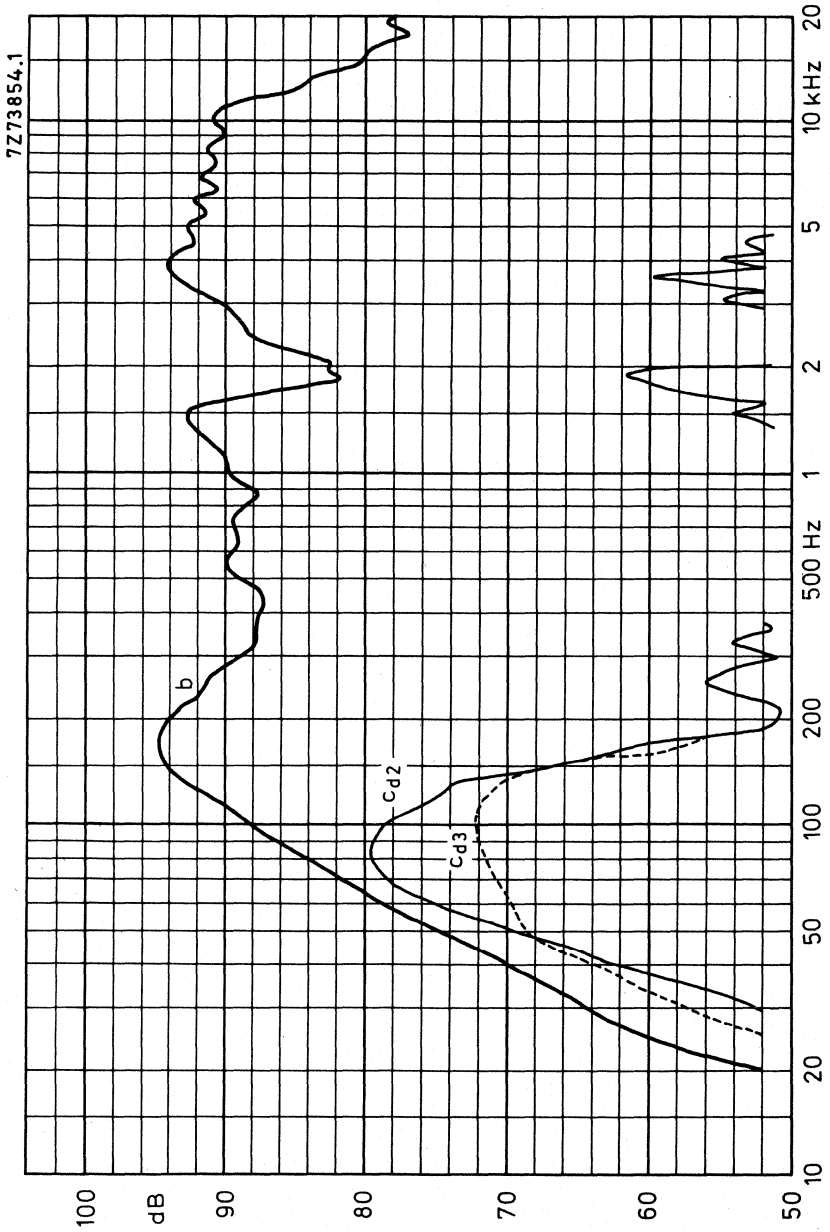

Fig. 2.

4 INCH MEDIUM POWER LOUDSPEAKERS

APPLICATION

For portable receivers and intercoms. Particularly suited for television receivers due to absence of stray field.

TECHNICAL DATA

	version				
	X4	X8	X15	X25	
Rated impedance	4	8	15	25	Ω
Voice coil resistance	3,4	7,1	13,5	22,5	Ω
Rated frequency range	80 to 15 000				Hz
Resonance frequency	150				Hz
Power handling capacity, loudspeaker unmounted, measured without filter	3				W
Operating power (sound level 90 dB, 0,5 m)	1	1,2	1	1	W
Sweep voltage (frequency range 75 to 20 000 Hz)	2,45	3,45	4,74	6,2	V
Energy in air gap	19				mJ
Flux density	0,77				T
Air-gap height	2,5				mm
Voice coil height	3,5	4,2	2,7	3,3	mm
Core diameter	14,5				mm
Magnet material	steel alloy				
diameter	14,5				mm
mass	0,013				kg
Mass of loudspeaker	0,11				kg



The loudspeakers have a paper cone and surround. Type AD4095/X. has a round flange, type AD4495/X. has a square flange. Connection to the loudspeakers is by means of 2,8 mm (0,11 inch) tag connectors or by soldering.

AD4095/X.
AD4495/X.

Dimensions in mm

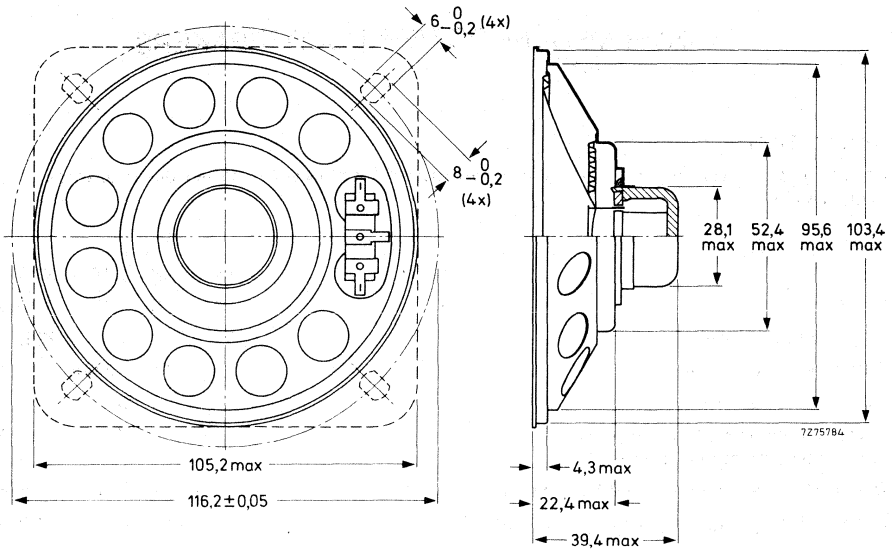

Fig. 1 The dotted lines show the square flange with fixing holes of type AD4495/X.

Baffle hole diameter 96 mm.

One tag is indicated by a red mark for in-phase connection.

→ AVAILABLE VERSIONS

Round flange type

- AD4095/X4, catalogue number 2422 256 24321
- AD4095/X8, catalogue number 2422 256 24322
- AD4095/X15, catalogue number 2422 256 24323
- AD4095/X25, catalogue number 2422 256 24324

Square flange type

- AD4495/X4, catalogue number 2422 256 24331
- AD4495/X8, catalogue number 2422 256 24332
- AD4495/X15, catalogue number 2422 256 24333
- AD4495/X25, catalogue number 2422 256 24334

these numbers apply to bulk packed loudspeakers, minimum packing quantity 99 per unit.

FREQUENCY RESPONSE CURVE (see Fig. 2)

Curve a: Sound pressure measured in anechoic room, loudspeaker mounted on IEC baffle.

Curves d2 and d3: 2nd and 3rd harmonic distortion measured at the operating power in anechoic room.

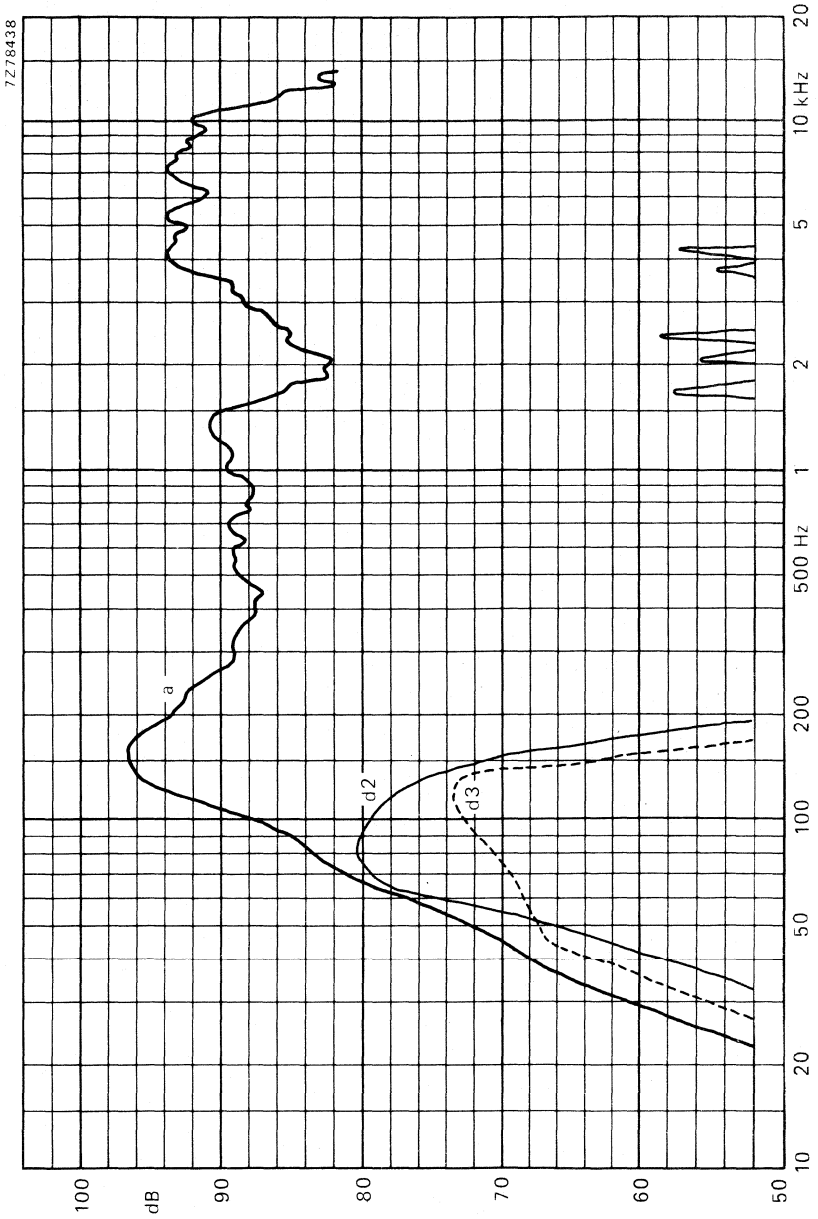

Fig. 2.



4 INCH MEDIUM POWER LOUDSPEAKER

APPLICATION

With its excellent power handling capacity very suitable for car radios.

TECHNICAL DATA

	version	
	X4	X8
Rated impedance	4	8 Ω
Voice coil resistance	3,4	7,1 Ω
Rated frequency range	90 to 14000 Hz	
Resonance frequency	140 Hz	
Power handling capacity, measured without filter loudspeaker unmounted	8 W	
Operating power (sound level 90 dB, 1 m)	0,8 W	
Sweep voltage (80 to 20 000 Hz)	3,5	5,7 V
Energy in air gap	50 mJ	
Flux density	0,95 T	
Air-gap height	3 mm	
Voice coil height	4,4	3,9 mm
Core diameter	18 mm	
Magnet material	ceramic	
diameter	54 mm	
mass	0,1 kg	
Mass of loudspeaker	0,25 kg	

The loudspeaker has a paper cone and a textile surround. Connection to the loudspeaker by means of 2,8 mm (0,11 inch) tag connectors or by soldering.



Dimensions in mm

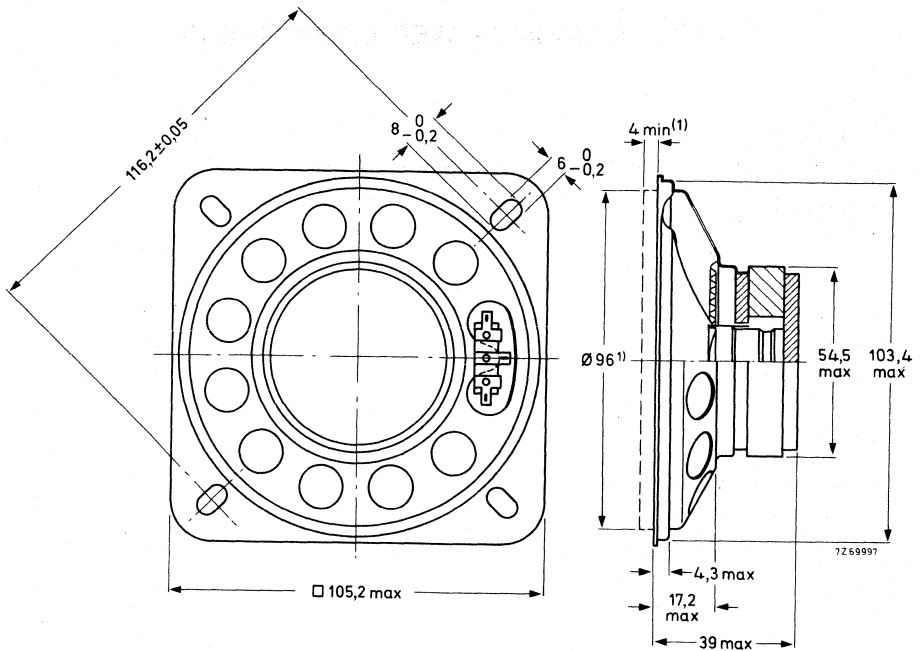

Fig. 1.

(1) Baffle hole and clearance depth required for cone movement at the specified power handling capacity.

One tag is indicated by a red mark for in-phase connection.

→ AVAILABLE VERSIONS

AD4481/X4, catalogue number 2422 257 34331
 AD4481/X8, catalogue number 2422 257 34437

these numbers apply to bulk packed loudspeakers, minimum packing quantity 99 per unit.

FREQUENCY RESPONSE CURVES (see Fig. 2)

Measured in anechoic room at the operating power of 0,8 W. Loudspeaker front mounted on IEC baffle.

Curve b: Sound pressure.

Curves c: 2nd and 3rd harmonic distortion.

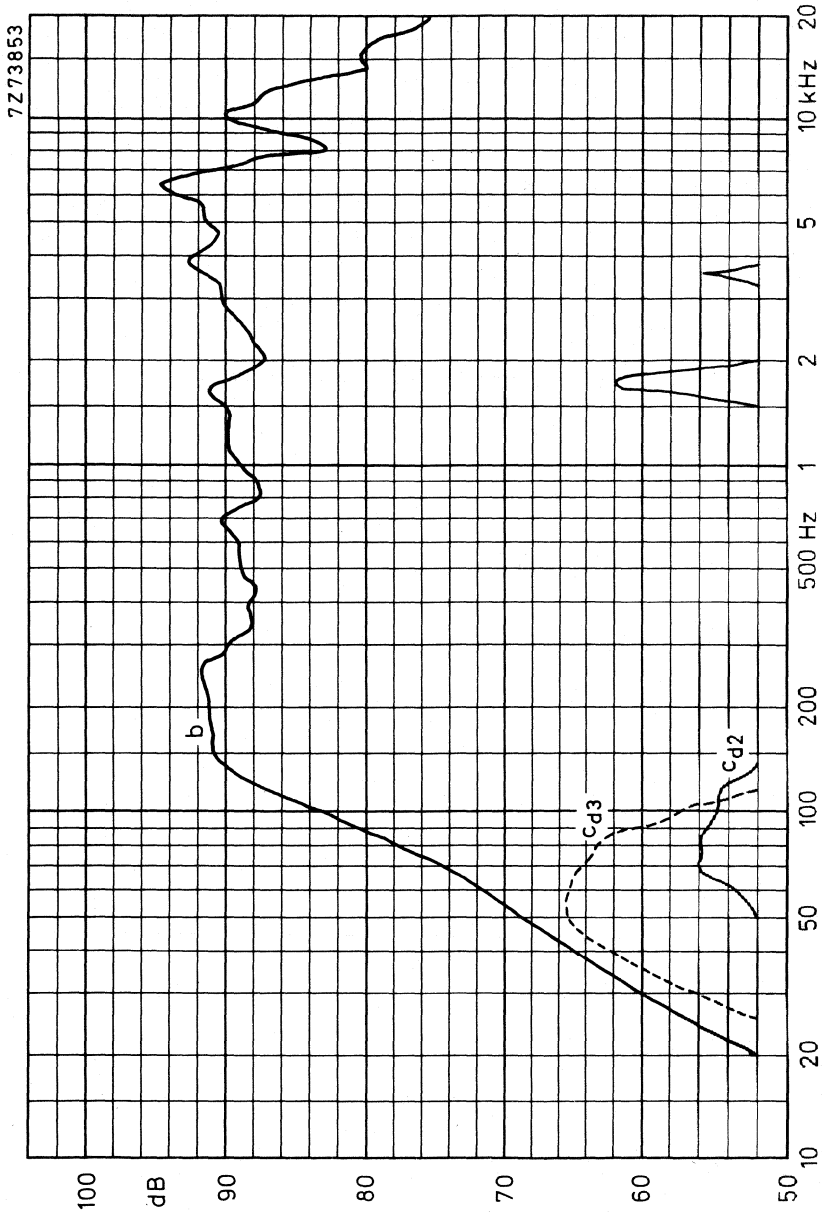

Fig. 2.



4 × 6 inch OVAL MEDIUM POWER LOUDSPEAKER

APPLICATION

A full range loudspeaker for car and domestic radios, tape recorders and portable record players.

This speaker has an extended frequency response up to 20 kHz.

TECHNICAL DATA

version

	M4	M8	M25
Rated impedance	4	8	25 Ω
Voice coil resistance	3,4	7,1	22,7 Ω
Resonance frequency	135	135	135 Hz
Power handling capacity, measured without filter loudspeaker unmounted	6	6	6 W
Sweep voltage	2,8	4	7,1 V
Energy in airgap	55	55	55 mJ
Flux density	1	1	1 T
Airgap height	3	3	3 mm
Voice coil height	4,5	3,9	4 mm
Core diameter	18	18	18 mm
Magnet material	ceramic	ceramic	ceramic
diameter	53	53	53 mm
mass	0,1	0,1	0,1 kg
Mass of loudspeaker	0,26	0,26	0,26 kg

The loudspeaker has a paper dual cone and surround and a foam plastic gasket on the flange. Connection to the loudspeaker by means of 2,8 mm (0,11 inch) tag connectors or by soldering.

Dimensions in mm

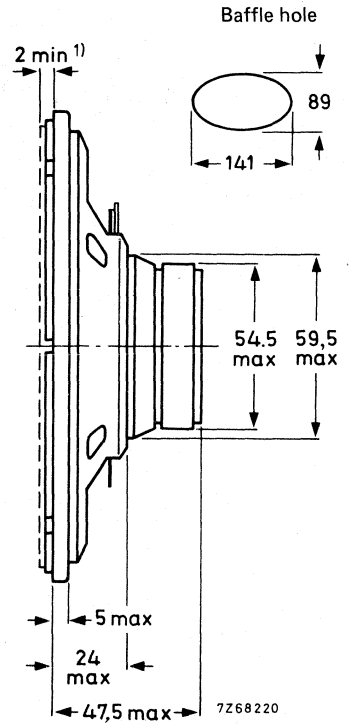
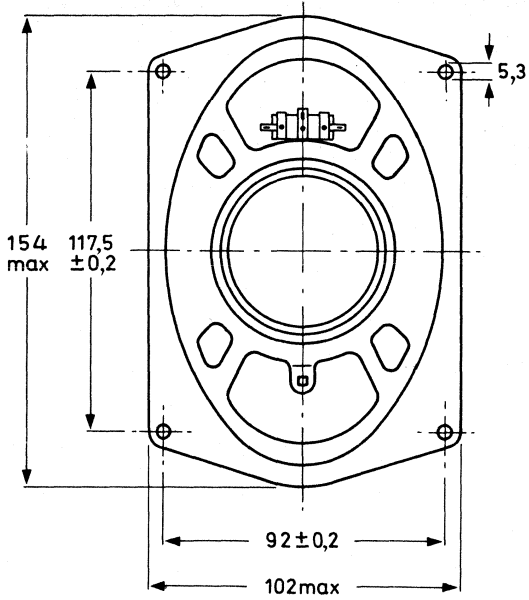

Fig. 1.

(1) Clearance depth required for cone movement at specified power handling capacity.
 One tag is indicated by a red mark for in-phase connection.

→ **AVAILABLE VERSIONS**

AD4681/M4, catalogue number 2422 257 30429
AD4681/M8, catalogue number 2422 257 30431
AD4681/M25, catalogue number 2422 257 30433

} these numbers apply to bulk
packed loudspeakers, minimum
packing quantity 63 per unit.

FREQUENCY RESPONSE CURVE

Fig. 2 Sound pressure measured in anechoic room, loudspeaker mounted on IEC baffle. Input power 50 mW.



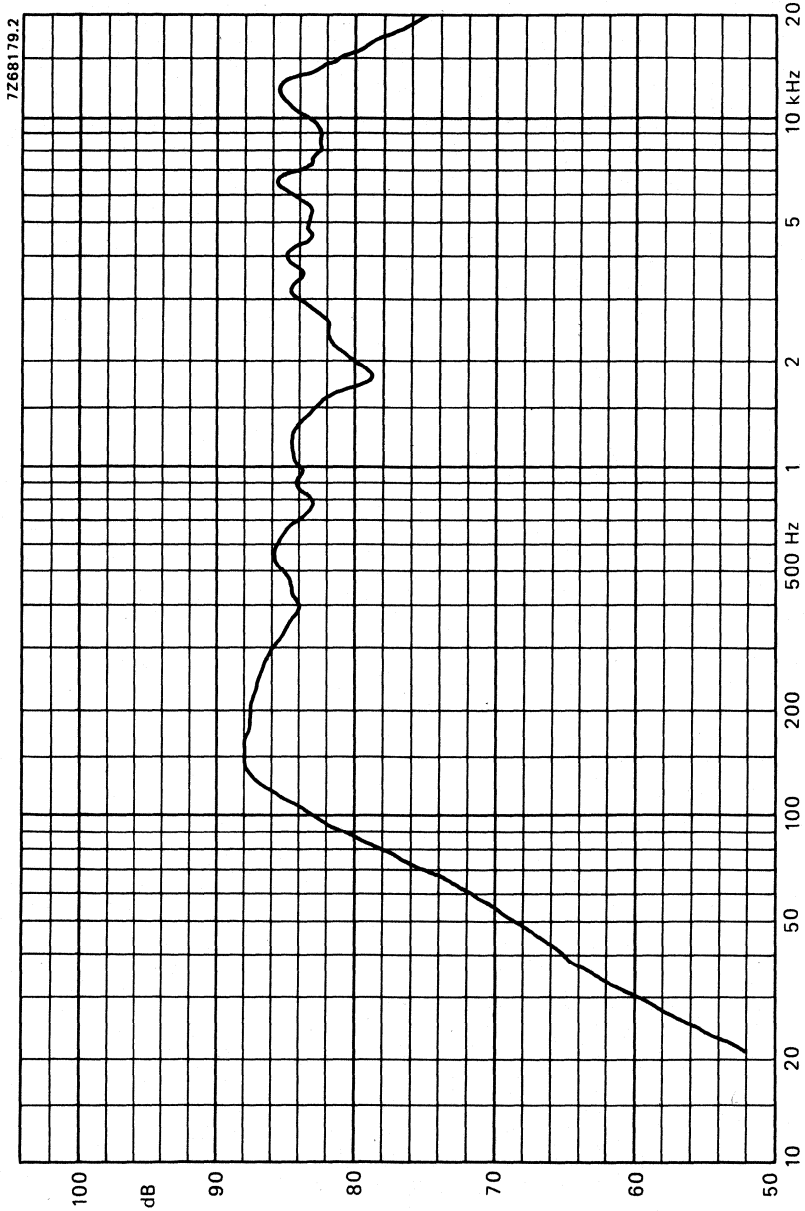

Fig. 2



4 x 6 INCH MEDIUM POWER LOUDSPEAKER

APPLICATION

For car and domestic radios, tape recorders and portables. High sensitivity at 3000 Hz.

TECHNICAL DATA

	version			
	X4	X8	X15	X25
Rated impedance	4	8	15	25 Ω
Voice coil resistance	3,1	7,1	13,5	22,7 Ω
Rated frequency range	75 to 12000			Hz
Resonance frequency	140			Hz
Power handling capacity, measured without filter loudspeaker unmounted	6			W
Sweep voltage	3,5	4,9	6,7	8,7 V
Energy in air gap	55			mJ
Flux density	1			T
Air-gap height	3			mm
Voice coil height	4,5	3,9	3,2	4 mm ←
Core diameter	18			mm
Magnet material	ceramic			
diameter	53			mm
mass	0,1			kg
Mass of loudspeaker	0,26			kg

The loudspeaker has a paper cone and surround and a foam plastic gasket on the flange. Connection to the loudspeaker by means of 2,8 mm (0,11 inch) tag connectors or by soldering.

Dimensions in mm

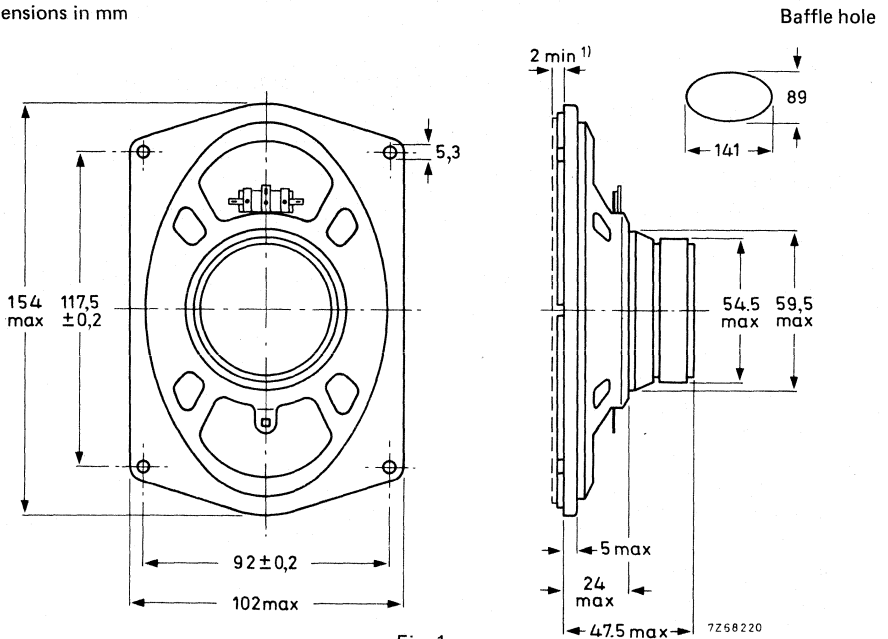

Fig. 1.

(1) Clearance depth required for cone movement at specified power handling capacity.
One tag is indicated by a red mark for in-phase connection.

→ AVAILABLE VERSIONS

- AD4681/X4, catalogue number 2422 257 30421
- AD4681/X8, catalogue number 2422 257 30422
- AD4681/X15, catalogue number 2422 257 30423
- AD4681/X25, catalogue number 2422 257 30424

these numbers apply to bulk packed loudspeakers, minimum packing quantity 63 per unit.

FREQUENCY RESPONSE CURVE (Fig. 2)

Input power 50 mW. Sound pressure measured in anechoic room, loudspeaker mounted on IEC baffle.

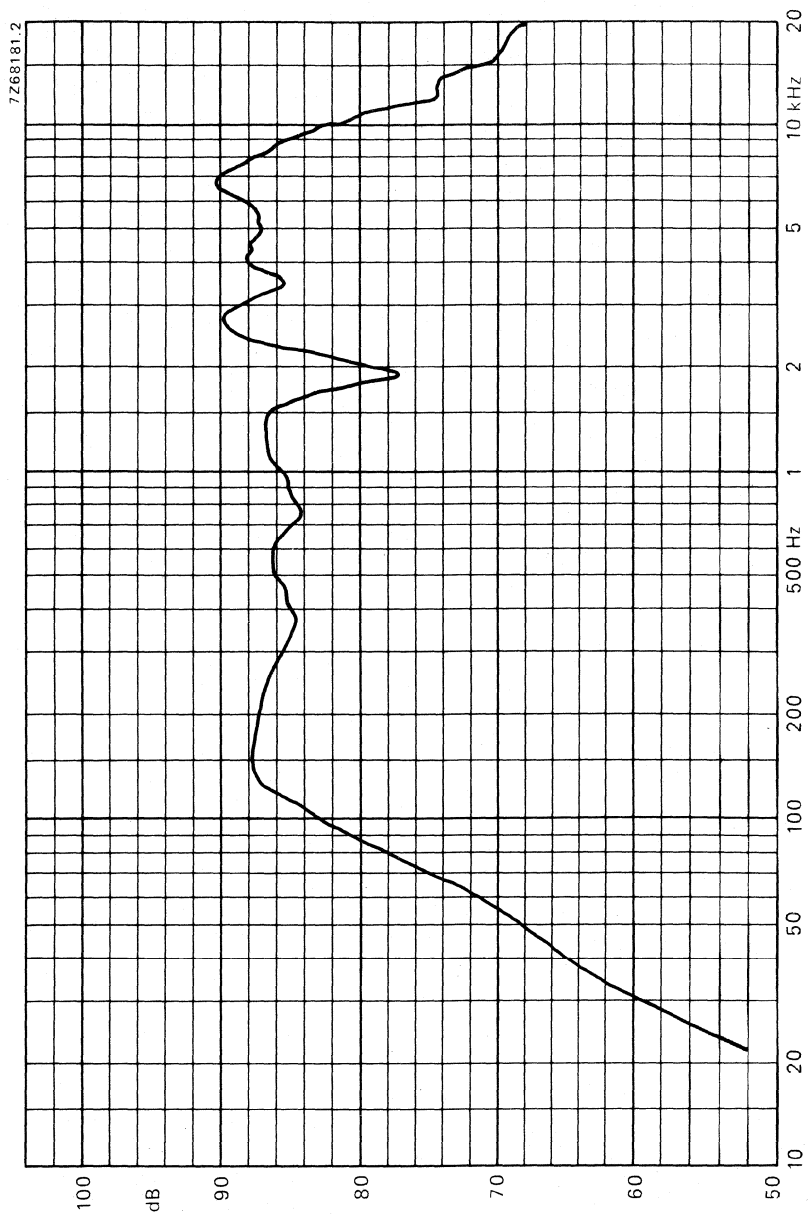

Fig. 2.



3½ x 6 inch OVAL MEDIUM POWER LOUDSPEAKERS

APPLICATION

For car and domestic radios, tape recorders, portable record players and intercoms.

TECHNICAL DATA

	version				
	X4	X8	X15	X25	
Rated impedance	4	8	15	25	Ω
Voice coil resistance	3,1	7,1	13,5	22,7	Ω
Rated frequency range	80 to 13 000				Hz
Resonance frequency	140				Hz
Power handling capacity, measured without filter, loudspeaker unmounted	6				W
Operating power (sound level 90 dB, 1 m)	0,7				W
Sweep voltage (70 to 20 000 Hz)	3,5	4,9	6,7	8,7	V
Energy in air gap	55				mJ
Flux density	1				T
Air-gap height	3				mm
Voice coil height	4,4	3,9	3,2	4	mm
Core diameter	18				mm
Magnet material	ceramic				
diameter	54				mm
mass	0,1				kg
Mass of loudspeaker	0,25				kg

The loudspeaker has a paper cone and surround and a foam plastic gasket. Connection to the loudspeaker by means of 2,8 mm (0,11 inch) tag connectors or by soldering.

Dimensions in mm

Baffle hole

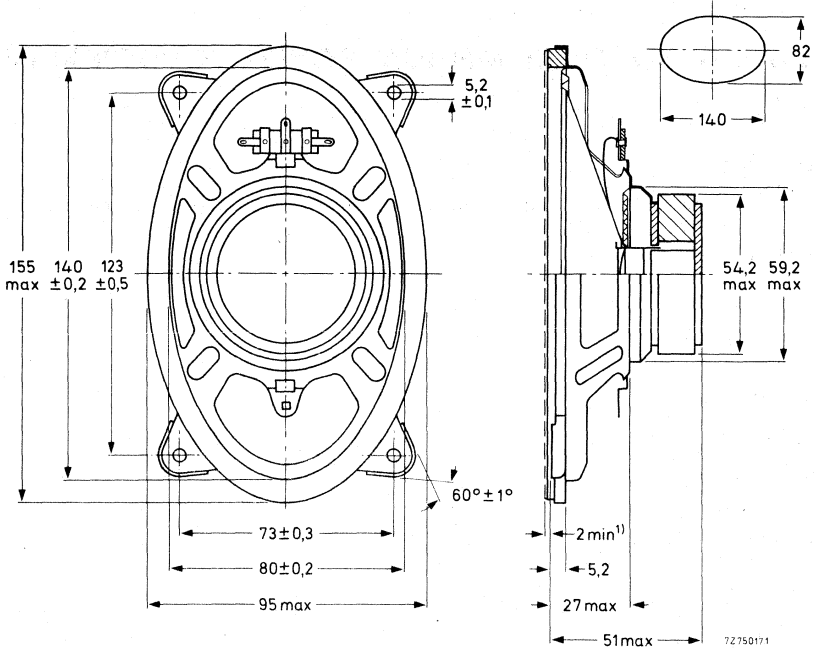

Fig. 1.

(1) Clearance depth required for cone movement at the specified power handling capacity. One tag is indicated by a red mark for in-phase connection.

→ AVAILABLE VERSIONS

- AD4682/X4, catalogue number 2422 257 30621
- AD4682/X8, catalogue number 2422 257 30622
- AD4682/X15, catalogue number 2422 257 30623
- AD4682/X25, catalogue number 2422 257 30624

} these numbers apply to bulk packed loudspeakers, minimum packing quantity 63 per unit.

FREQUENCY RESPONSE CURVES (see Fig. 2)

Curve b: Sound pressure measured in anechoic room, loudspeaker mounted on baffle according to IEC268-5, par. 4.4.

Curve c: 2nd and 3rd harmonic distortion, measured at the operating power of 0,7 W in anechoic room. Loudspeaker front mounted on IEC baffle.

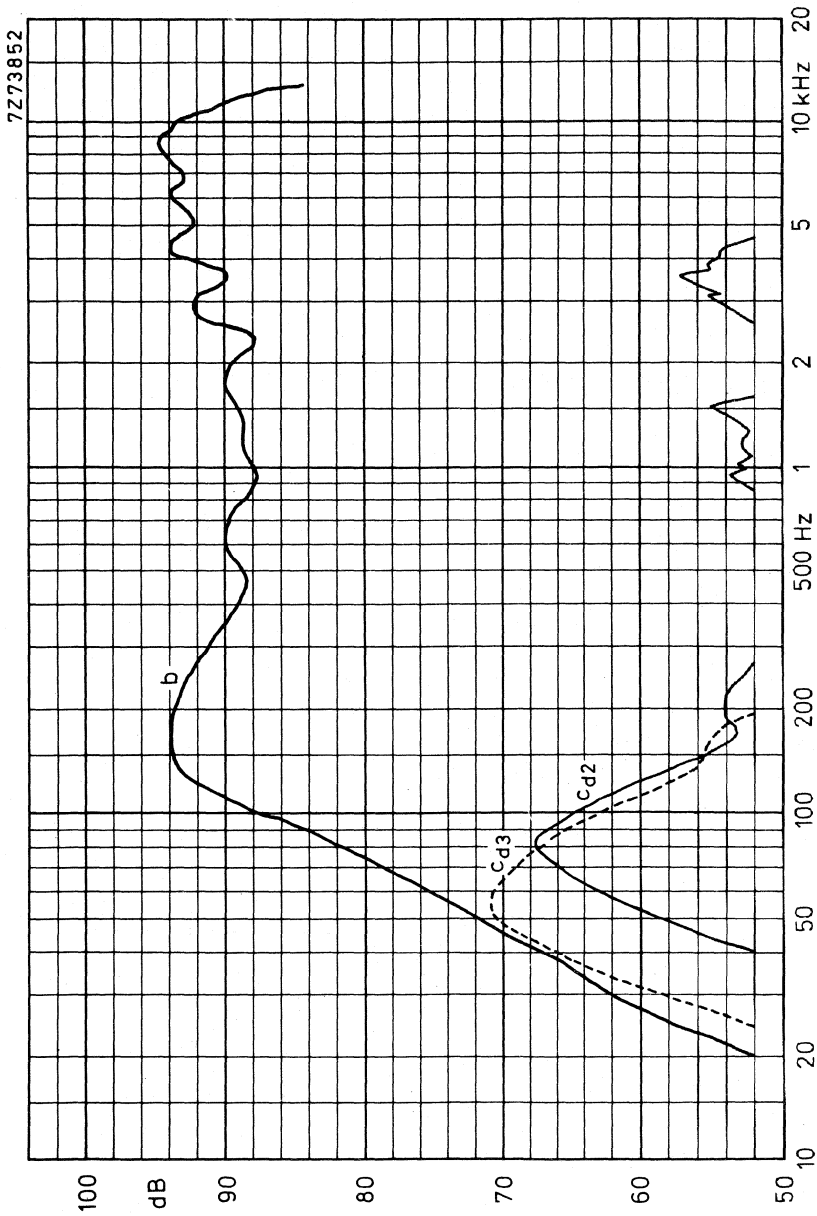

Fig. 2



DEVELOPMENT SAMPLE DATA

This information is derived from development samples made available for evaluation. It does not necessarily imply that the device will go into regular production.

AD4683/M.

4 x 6 INCH MEDIUM POWER LOUDSPEAKER

APPLICATION

For black and white television sets. Low stray field and high sensitivity due to screened ceramic magnet system.

TECHNICAL DATA

	version			
	M4	M8	M15	M25
Rated impedance	4	8	15	25 Ω
Voice coil resistance	3,4	7,1	13,5	22,7 Ω
Rated frequency range		80 to 18 000		Hz
Resonance frequency		140		Hz
Power handling capacity, measured without filter, loudspeaker unmounted		6		W
Operating power (sound level 90 dB, 1 m)		1		W
Sweep voltage (70 to 20 000 Hz)	3,5	4,1	6,7	8,7 V
Energy in air gap		39		mJ
Flux density		0,8		T
Air-gap height		3		mm
Voice coil height	4,4	3,9	3,2	4 mm
Core diameter		18		mm
Magnet material		ceramic		
diameter		54		mm
mass		0,1		kg
Mass of loudspeaker		0,3		kg

The loudspeaker has a paper dual cone and surround and a foam plastic gasket. Connection to the loudspeaker by means of 2,8 mm (0,11 inch) tag connectors or by soldering.

Dimensions in mm

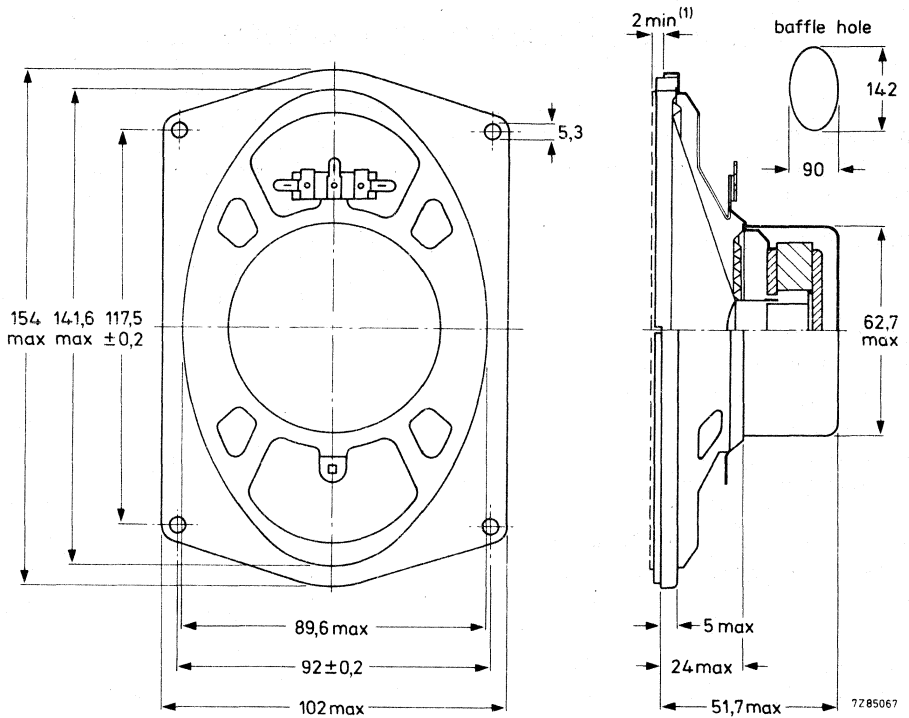

Fig. 1.

(1) Clearance depth required for cone movement at the specified power handling capacity.
One tag is indicated by a red mark for in-phase connection.

→ AVAILABLE VERSIONS

AD4682/M4	catalogue number 2422 257 30525	} these numbers apply to bulk-packed loudspeakers, minimum packing quantity 63 per unit.
AD4682/M8	catalogue number 2422 257 30526	
AD4682/M15	catalogue number 2422 257 30527	
AD4682/M25	catalogue number 2422 257 30528	

FREQUENCY RESPONSE CURVES (see Fig. 2)

Measured in anechoic room at the operating power. Loudspeaker front mounted on IEC baffle.

Curve a: Sound pressure.

Curves d2 and d3: 2nd and 3rd harmonic distortion.

DEVELOPMENT SAMPLE DATA

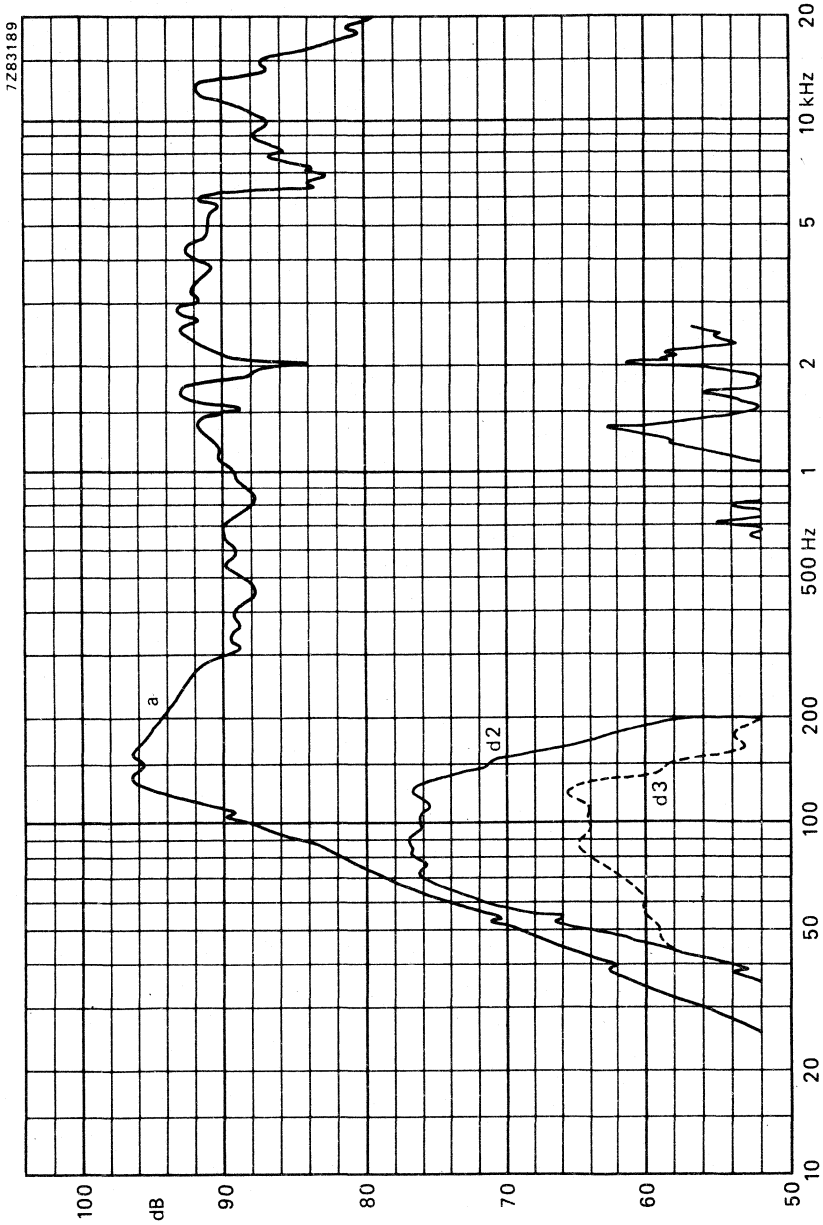

Fig. 2.



4 x 6 INCH MEDIUM POWER LOUDSPEAKER

APPLICATION

For black and white television sets. Low stray field and high sensitivity due to screened ceramic magnet system.

TECHNICAL DATA

	version			
	X4	X8	X15	X25
Rated impedance	4	8	15	25 Ω
Voice coil resistance	3,4	7,1	13,5	22,7 Ω
Rated frequency range	70 to 11 000			Hz
Resonance frequency	140			Hz
Power handling capacity, measured without filter, loudspeaker unmounted	6			W
Operating power (sound level 90 dB, 1 m)	0,8			W
Sweep voltage (70 to 20 000 Hz)	3,5	4,9	6,7	8,7 V
Energy in air gap	39			mJ
Flux density	0,8			T
Air-gap height	3			mm
Voice coil height	4,5	3,9	3,2	4 mm
Core diameter	18			mm
Magnet material	ceramic			
diameter	54			mm
mass	0,1			kg
Mass of loudspeaker	0,3			kg

The loudspeaker has a paper cone and surround and a foam plastic gasket. Connection to the loudspeaker by means of 2,8 mm (0,11 inch) tag connectors or by soldering.

Dimensions in mm

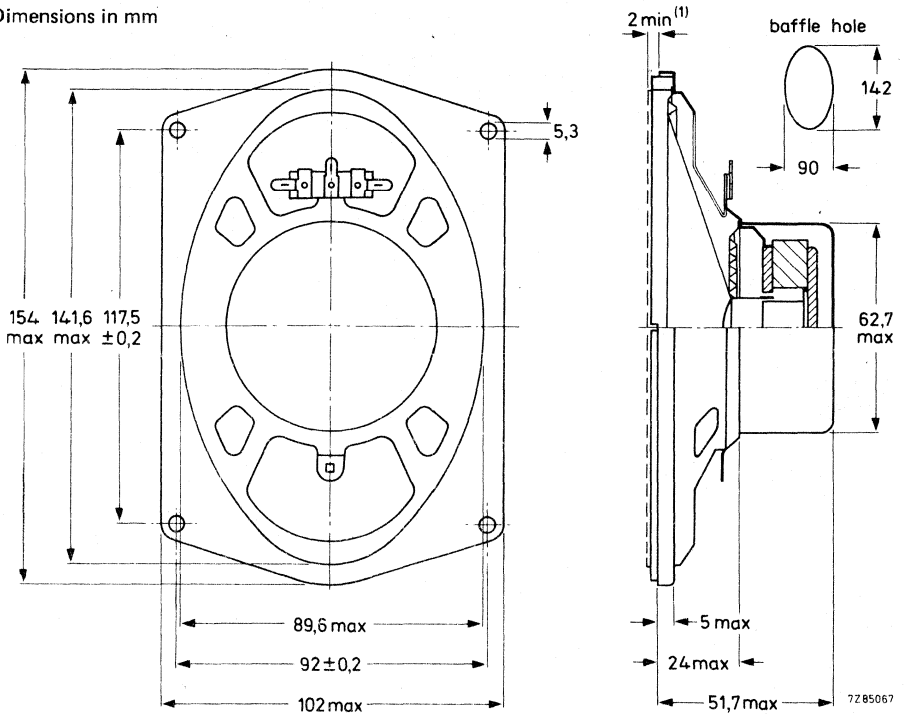

Fig. 1.

(1) Clearance depth required for cone movement at the specified power handling capacity. One tag is indicated by a red mark for in-phase connection.

→ AVAILABLE VERSIONS

AD4683/X4	catalogue number 2422 257 30521	} these numbers apply to bulk-packed loudspeakers, minimum packing quantity 63 per unit.
AD4683/X8	catalogue number 2422 257 30522	
AD4683/X15	catalogue number 2422 257 30523	
AD4683/X25	catalogue number 2422 257 30524	

FREQUENCY RESPONSE CURVES (see Fig. 2)

Measured in anechoic room at the operating power. Loudspeaker front mounted on IEC baffle.

Curve a: Sound pressure.

Curves d2 and d3: 2nd and 3rd harmonic distortion.

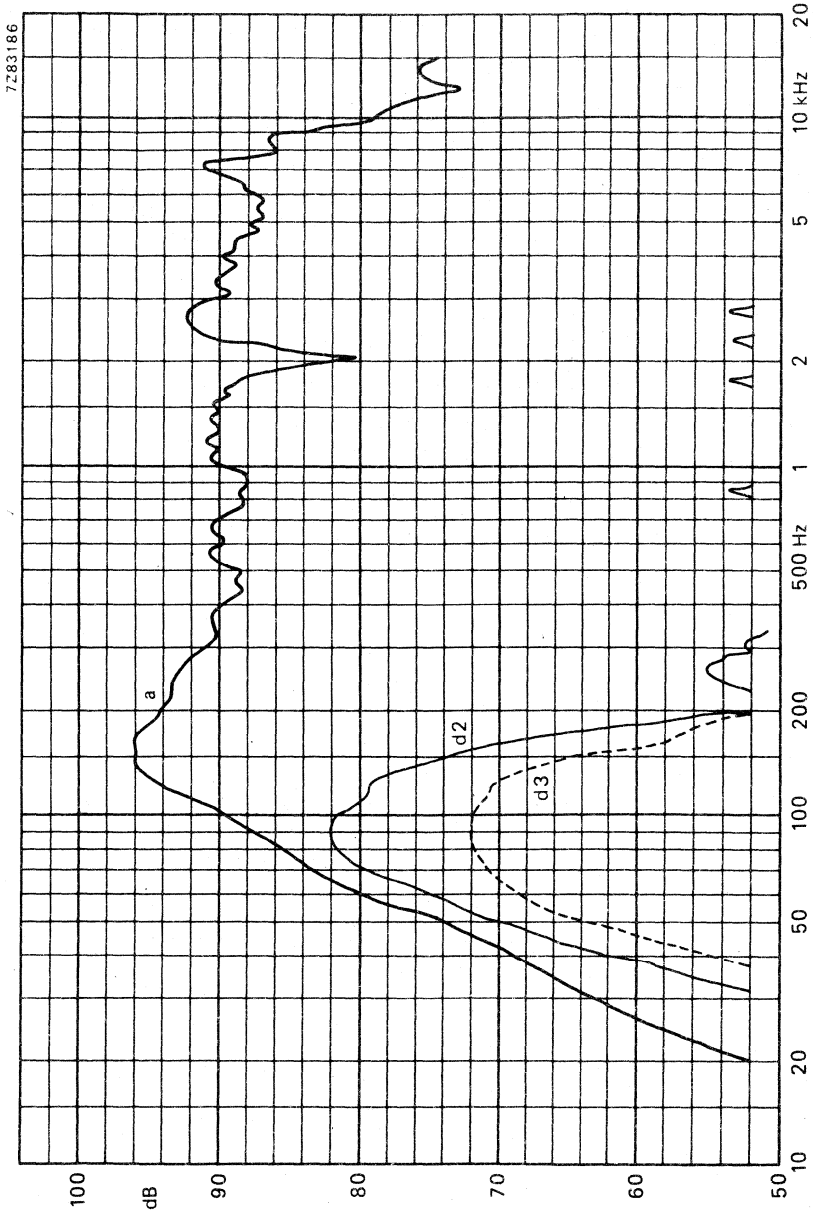

Fig. 2.



3½ x 6 INCH MEDIUM POWER LOUDSPEAKER

APPLICATION

For black and white television sets. Low stray field and high sensitivity due to screened ceramic magnet system.

TECHNICAL DATA

	version				
	X4	X8	•X15	X25	
Rated impedance	4	8	15	25	Ω
Voice coil resistance	3,4	7,1	13,5	22,7	Ω
Rated frequency range	70 to 12 000				Hz
Resonance frequency	140				Hz
Power handling capacity, measured without filter, loudspeaker unmounted	6				W
Operating power (sound level 90 dB, 1 m)	0,8				W
Sweep voltage (70 to 20 000 Hz)	3,5	4,9	6,7	8,7	V
Energy in air gap	39				mJ
Flux density	0,8				T
Air-gap height	3				mm
Voice coil height	4,5	3,9	3,2	4	mm
Core diameter	18				mm
Magnet material	ceramic				
diameter	54				mm
mass	0,1				kg
Mass of loudspeaker	0,29				kg

The loudspeaker has a paper cone and surround and a foam plastic gasket. Connection to the loudspeaker by means of 2,8 mm (0,11 inch) tag connectors or by soldering.

Dimensions in mm

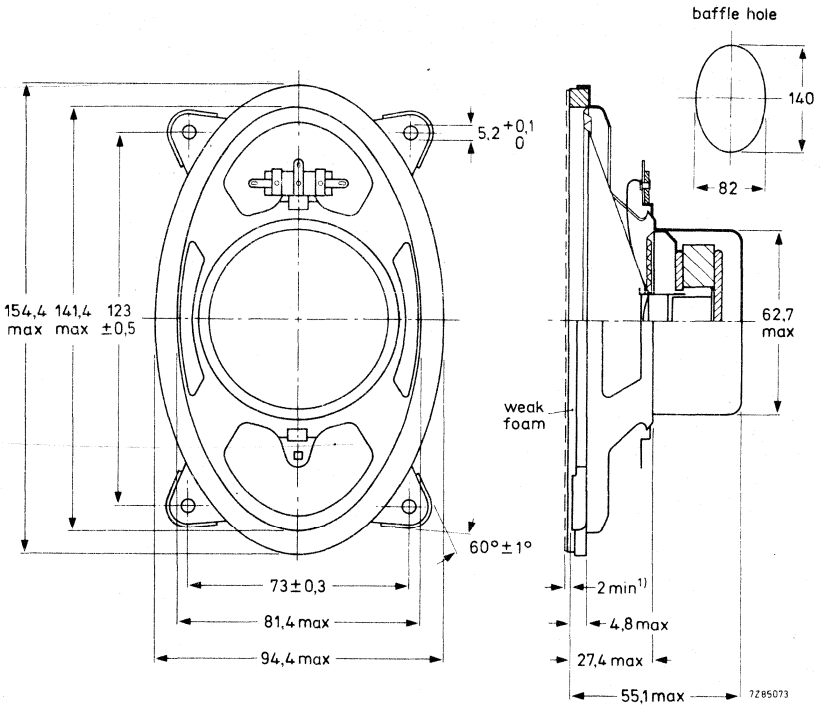

Fig. 1.

(1) Clearance depth required for cone movement at the specified power handling capacity. One tag is indicated by a red mark for in-phase connection.

→ AVAILABLE VERSIONS

AD4684/X4	catalogue number 2422 257 30921
AD4684/X8	catalogue number 2422 257 30922
AD4684/X15	catalogue number 2422 257 30923
AD4684/X25	catalogue number 2422 257 30924

} these numbers apply to bulk-packed loudspeakers, minimum packing quantity 63 per unit.

FREQUENCY RESPONSE CURVES (see Fig. 2)

Measured in anechoic room at the operating power. Loudspeaker front mounted on IEC baffle.

Curve a: Sound pressure.

Curves d2 and d3: 2nd and 3rd harmonic distortion.

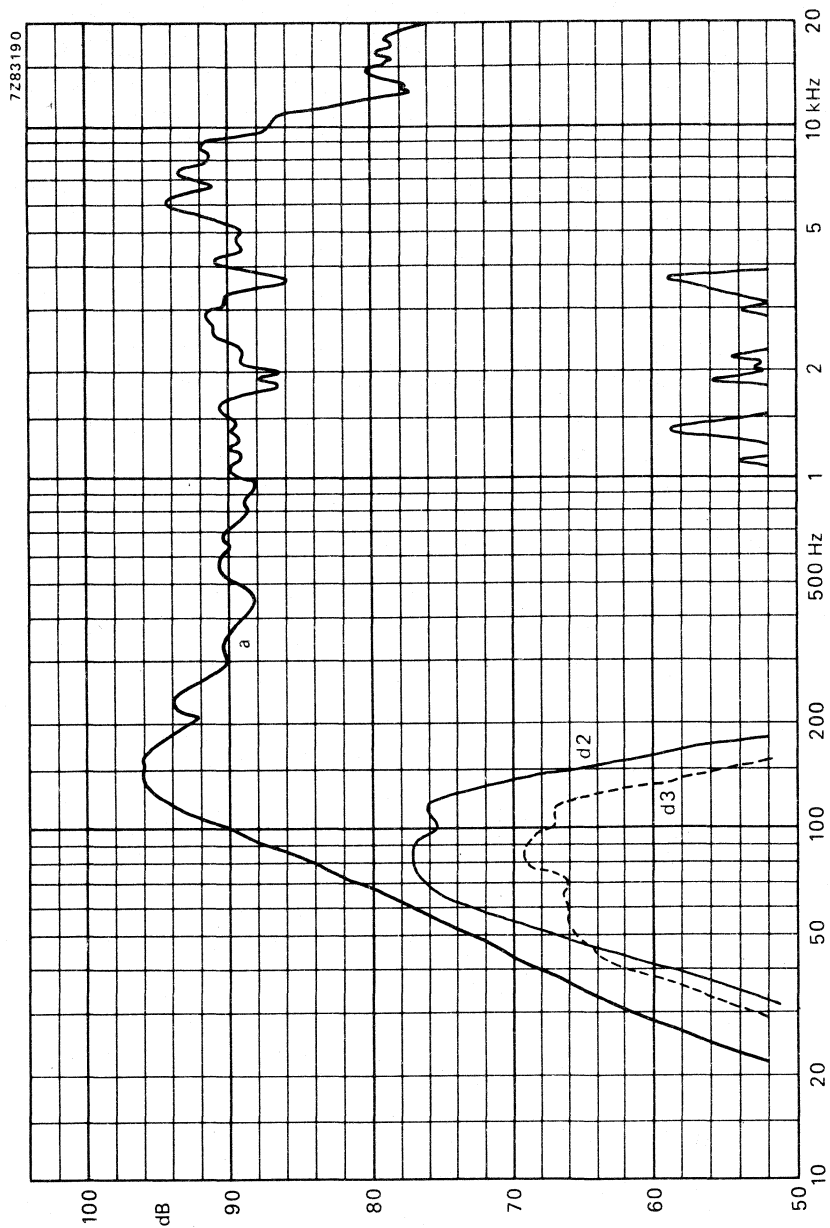

Fig. 2.



3½ x 6 INCH MEDIUM POWER LOUDSPEAKER

APPLICATION

For car and domestic radios, tape recorders, portable record players, and intercoms.

TECHNICAL DATA

	version		
	X4	X8	
Rated impedance	4	8	Ω
Voice coil resistance	3,4	7,1	Ω
Rated frequency range	70 to 15000		Hz
Resonance frequency	140		Hz
Power handling capacity, measured without filter, loudspeaker unmounted	4		W
Operating power (sound level 90 dB, 1 m)	1		W
Sweep voltage (70 to 20 000 Hz)	2,8	4	V
Energy in air gap	38		mJ
Flux density	1,1		T
Air-gap height	2,5		mm
Voice coil height	3,5	4,2	mm
Core diameter	14,5		mm
Magnet material	ceramic		
diameter	46		mm
mass	0,05		kg
Mass of loudspeaker	0,12		kg

The loudspeaker has a paper cone and surround and a foam plastic gasket. Connection to the loudspeaker by means of 2,8 mm (0,11 inch) tag connectors or by soldering.

Dimensions in mm

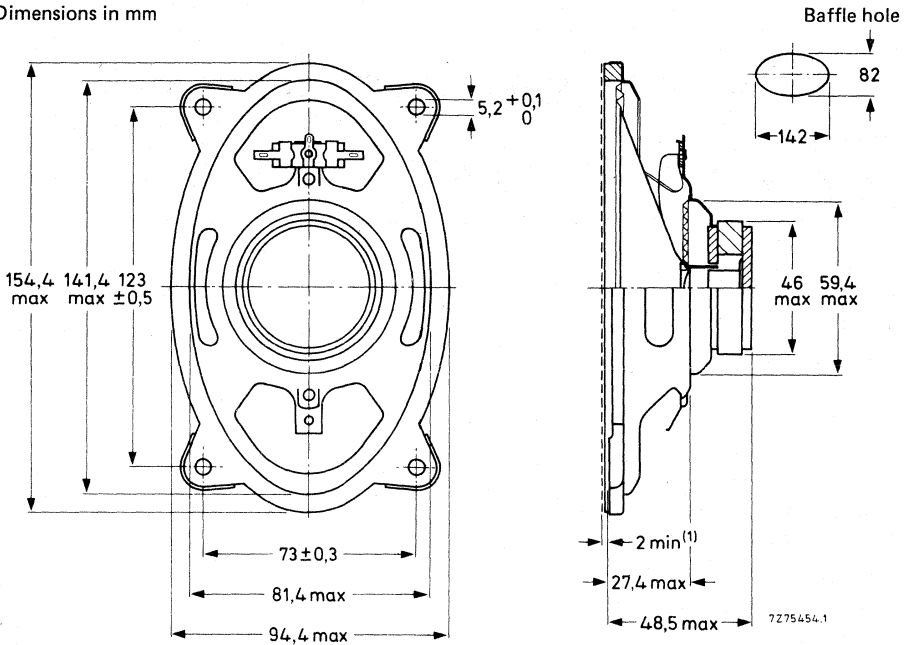

Fig. 1.

(1) Clearance depth required for cone movement at the specified power handling capacity. One tag is indicated by a red mark for in-phase connection.

→ AVAILABLE VERSIONS

AD4685/X4, catalogue number 2422 257 30721
 AD4685/X8, catalogue number 2422 257 30722

} these numbers apply to bulk packed loudspeakers, minimum packing quantity 63 per unit.

FREQUENCY RESPONSE CURVES (see Fig. 2)

Curve a: Sound pressure.

Curves d2 and d3: 2nd and 3rd harmonic distortion, measured at the operating power of 1 W.

The curves are measured in anechoic room, loudspeaker mounted on IEC baffle.

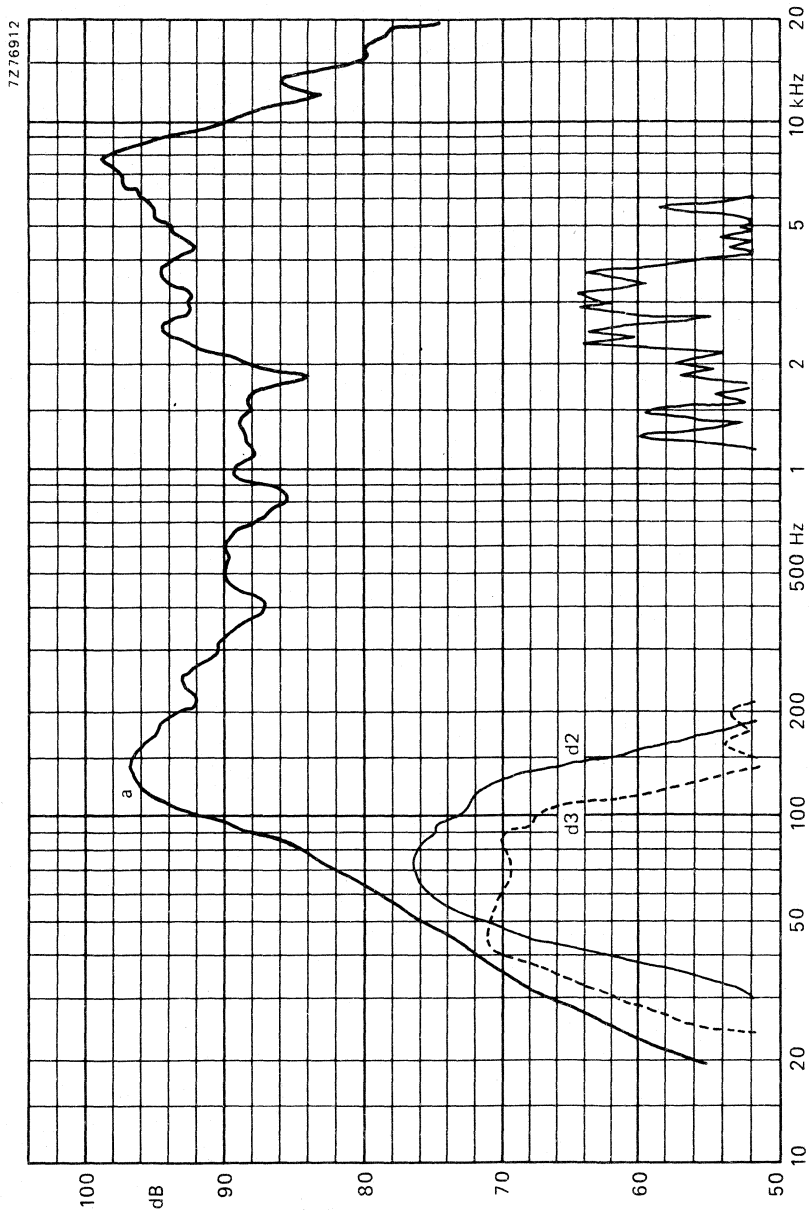

Fig. 2.



4 x 6 INCH MEDIUM POWER LOUDSPEAKER ←

APPLICATION

For car and domestic radios, tape recorders, portable record players and intercoms, where limited depth is available.

TECHNICAL DATA

	version				
	X4	X8	X15	X25	
Rated impedance	4	8	15	25	Ω
Voice coil resistance	3,4	7,1	13,5	22,5	Ω
Rated frequency range	80 to 13 000				Hz
Resonance frequency	140				Hz
Power handling capacity, measured without filter, loudspeaker unmounted	4				W
Operating power (sound level 90 dB, 1 m)	0,7	0,9	0,7	0,7	W
Sweep voltage (70 to 20 000 Hz)	2,8	4,0	5,5	7,1	V
Energy in air gap	38				mJ
Flux density	1,1				T
Air-gap height	2,5				mm
Voice coil height	3,5	4,2	2,7	2,7	mm
Core diameter	14,5				mm
Magnet material	ceramic				
diameter	46				mm
mass	0,1				kg
Mass of loudspeaker	0,26				kg

The loudspeaker has a paper cone and surround and a foam plastic gasket. Connection to the loudspeaker by means of 2,8 mm (0,11 inch) tag connectors or by soldering.

Dimensions in mm

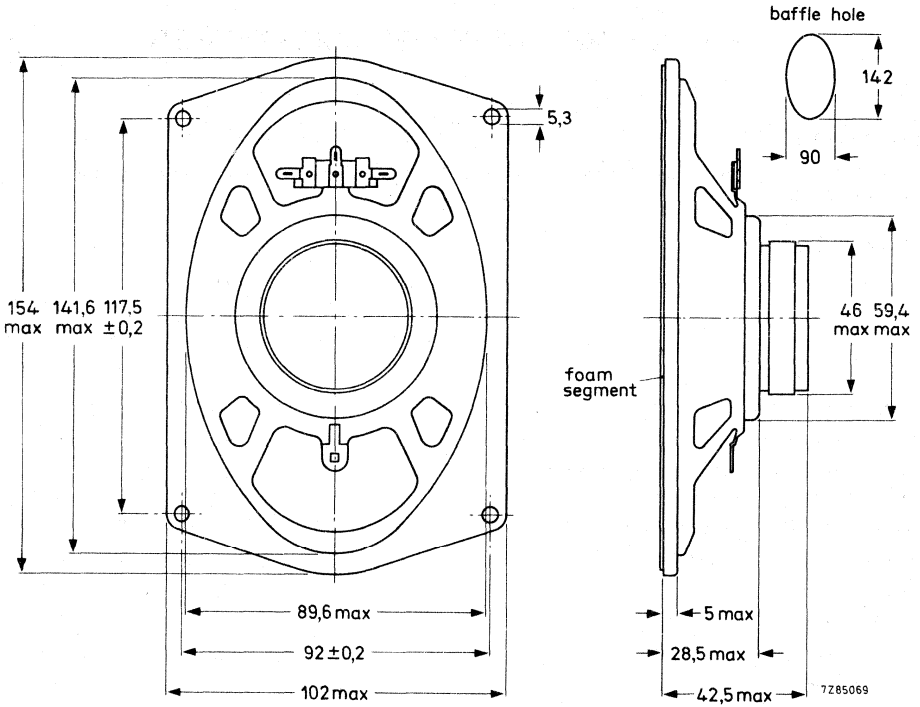

Fig. 1.

One tag is indicated by a red mark for in-phase connection.

→ AVAILABLE VERSIONS

AD4686/X4	catalogue number 2422 257 30821
AD4686/X8	catalogue number 2422 257 30822
AD4686/X15	catalogue number 2422 257 30823
AD4686/X25	catalogue number 2422 257 30824

} these numbers apply to bulk-packed loudspeakers, minimum packing quantity 63 per unit.

FREQUENCY RESPONSE CURVES (see Fig. 2)

Measured in anechoic room at the operating power. Loudspeaker front mounted on IEC baffle.

Curve a: Sound pressure.

Curves d2 and d3: 2nd and 3rd harmonic distortion.

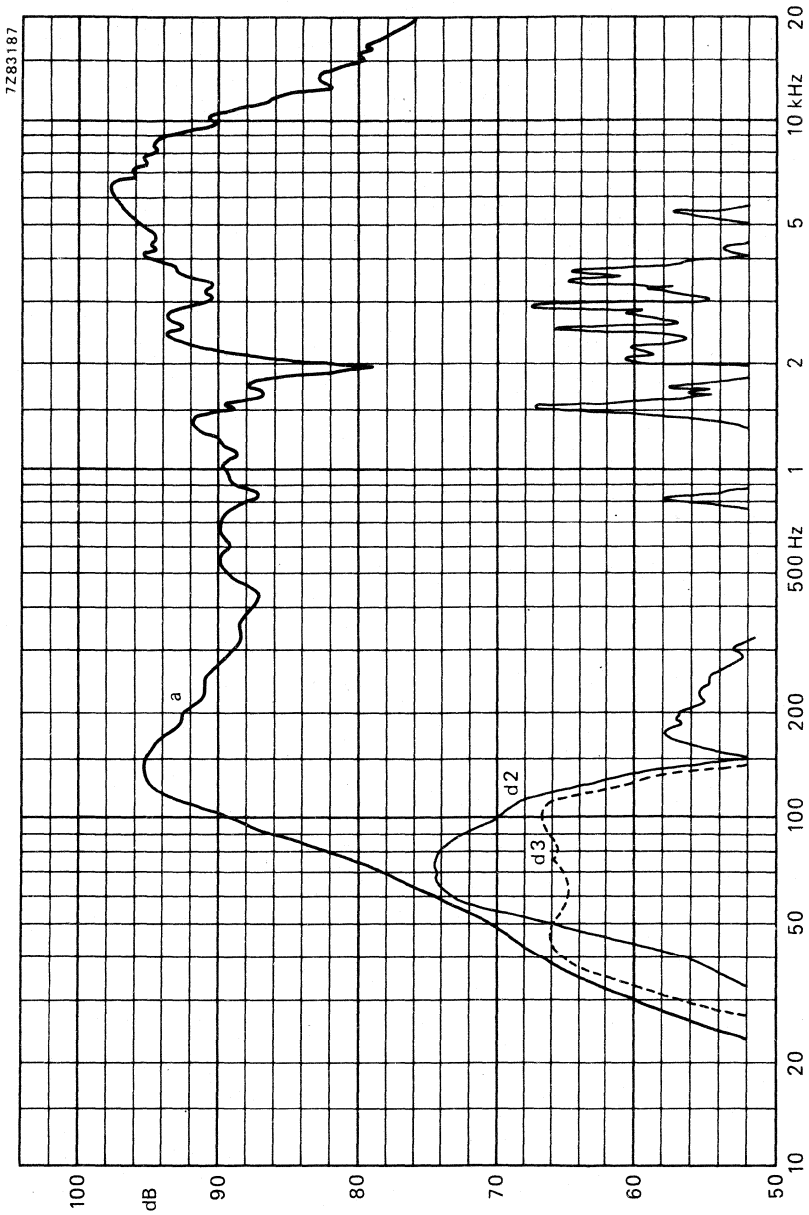

Fig. 2.



4 x 6 inch OVAL MEDIUM POWER LOUDSPEAKER

APPLICATION

A full range loudspeaker with an extended frequency response up to 20 kHz.

This loudspeaker can be used for black and white as well as colour television sets due to absence of stray field from the magnet system.

TECHNICAL DATA

	version			
	M4	M8	M15	M25
Rated impedance	4	8	15	25 Ω
Voice coil resistance	3,4	7,1	13,5	22,7 Ω
Resonance frequency	135	135	135	135 Hz
Power handling capacity, measured without filter loudspeaker unmounted	6	6	6	6 W
Sweep voltage	3,5	4,9	6,7	8,7 V ←
Energy in airgap	39	39	39	39 mJ
Flux density	0,8	0,8	0,8	0,8 T
Airgap height	3	3	3	3 mm
Voice coil height	4,5	3,9	3,2	4 mm
Core diameter	18	18	18	18 mm
Magnet material	steel alloy	steel alloy	steel alloy	steel alloy
diameter	18	18	18	18 mm
mass	0,027	0,027	0,027	0,027 kg
Mass of loudspeaker	0,16	0,16	0,16	0,16 kg

The loudspeaker has a paper dual cone and surround and a foam plastic gasket on the flange. Connection to the loudspeaker by means of 2,8 mm (0,11 inch) tag connectors or by soldering.

Dimensions in mm

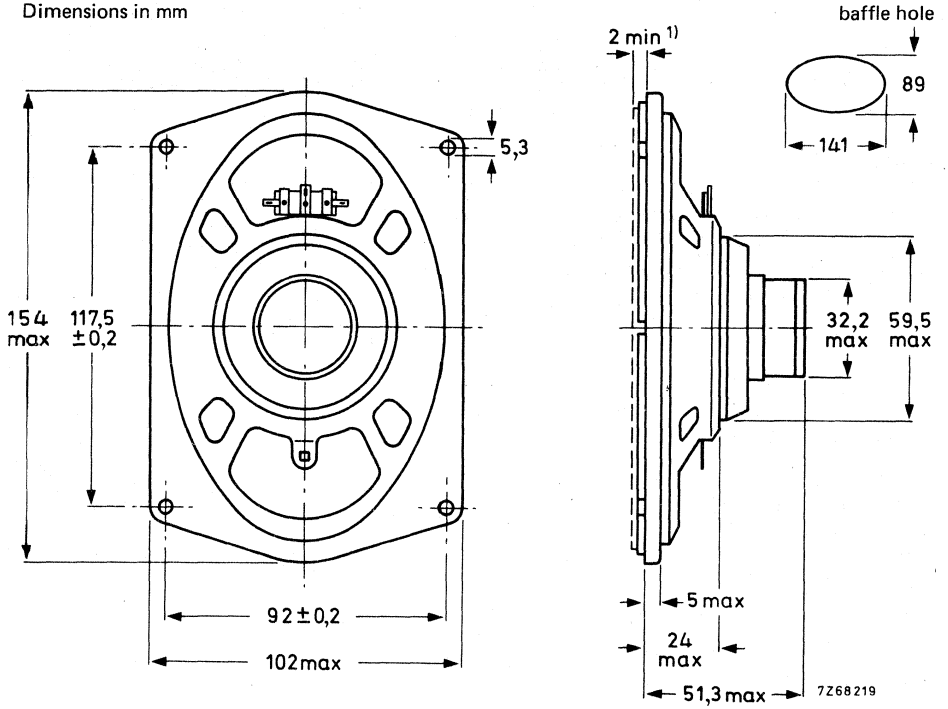

Fig. 1.

(1) Clearance depth required for cone movement at the specified power handling capacity.
 One tag is indicated by a red mark for in-phase connection.

➔ **AVAILABLE VERSIONS**

AD4691/M4, catalogue number 2422 256 30632
AD4691/M8, catalogue number 2422 256 30635
AD4691/M15, catalogue number 2422 256 30634
AD4691/M25, catalogue number 2422 256 30636

} these numbers apply to bulk
packed loudspeakers, minimum
packing quantity 63 per unit.

FREQUENCY RESPONSE CURVE

Fig. 2 Sound pressure measured in anechoic room, loudspeaker mounted on IEC baffle. Input power 50 mW.



AD4691/M.

4 x 6 inch OVAL MEDIUM POWER
LOUDSPEAKER

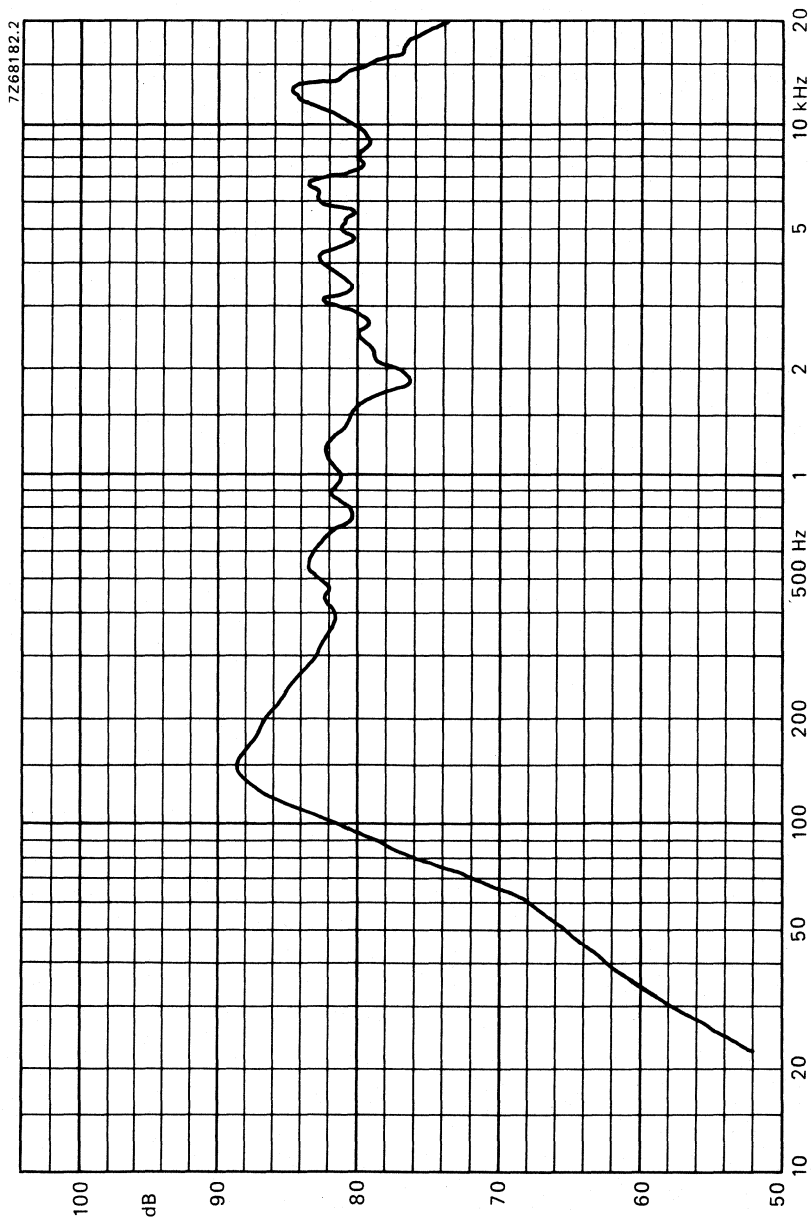

Fig.2

4 × 6 inch OVAL MEDIUM POWER LOUDSPEAKER

APPLICATION

The absence of stray field makes this loudspeaker very suitable for use in black and white as well as colour television sets.

High sensitivity at 3000 Hz. Frequency response up to 12 kHz.

TECHNICAL DATA

	version				
	X4	X8	X15	X25	
Rated impedance	4	8	15	25	Ω
Voice coil resistance	3,4	7,1	13,5	22,7	Ω
Resonance frequency	140	140	140	140	Hz
Power handling capacity, measured without filter, loudspeaker unmounted	6	6	6	6	W
Sweep voltage	3,5	4,9	6,7	8,7	V
Energy in airgap	39	39	39	39	mJ
Flux density	0,8	0,8	0,8	0,8	T
Airgap height	3	3	3	3	mm
Voice coil height	4,5	3,9	3,2	4	mm
Core diameter	18	18	18	18	mm
Magnet material	steel alloy	steel alloy	steel alloy	steel alloy	
diameter	18	18	18	18	mm
mass	0,027	0,027	0,027	0,027	kg
Mass of loudspeaker	0,16	0,16	0,16	0,16	kg

The loudspeaker has a paper cone and surround and a foam plastic gasket on the flange. Connection to the loudspeaker by means of 2,8 mm (0,11 inch) tag connectors or by soldering.

Dimensions in mm

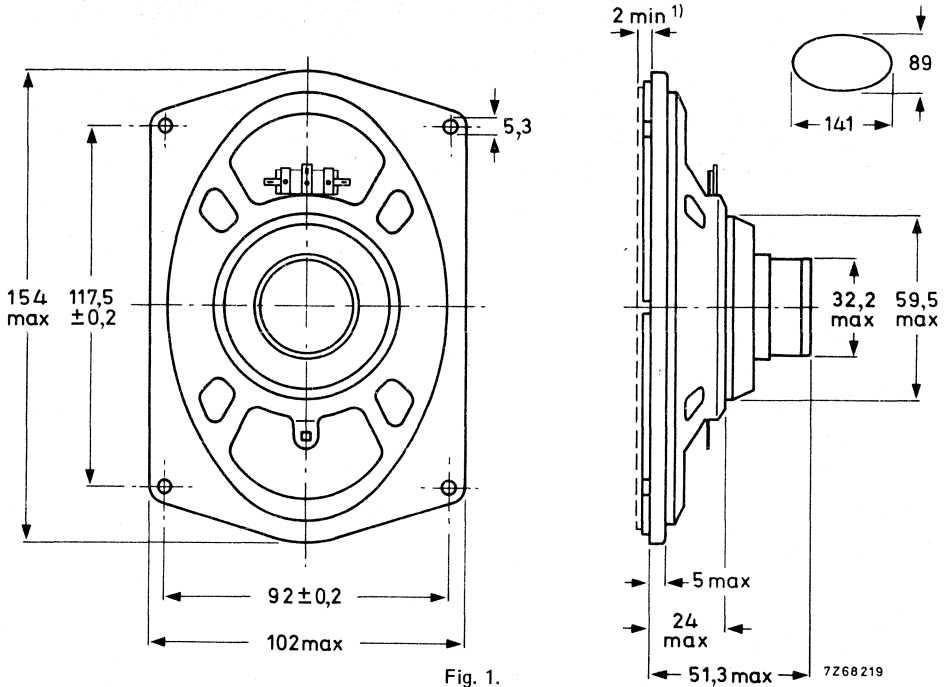

(1) Clearance depth required for cone movement at the specified power handling capacity.
 One tag is indicated by a red mark for in-phase connection.

→ AVAILABLE VERSIONS

- AD4691/X4, catalogue number 2422 256 30621
- AD4691/X8, catalogue number 2422 256 30622
- AD4691/X15, catalogue number 2422 256 30623
- AD4691/X25, catalogue number 2422 256 30624

} these numbers apply to bulk packed loudspeakers, minimum packing quantity 63 per unit.

FREQUENCY RESPONSE CURVE

Fig. 2 Input power 50 mW. Sound pressure measured in anechoic room, loudspeaker mounted on IEC baffle.

4 x 6 inch OVAL MEDIUM POWER
LOUDSPEAKER

AD4691/X.

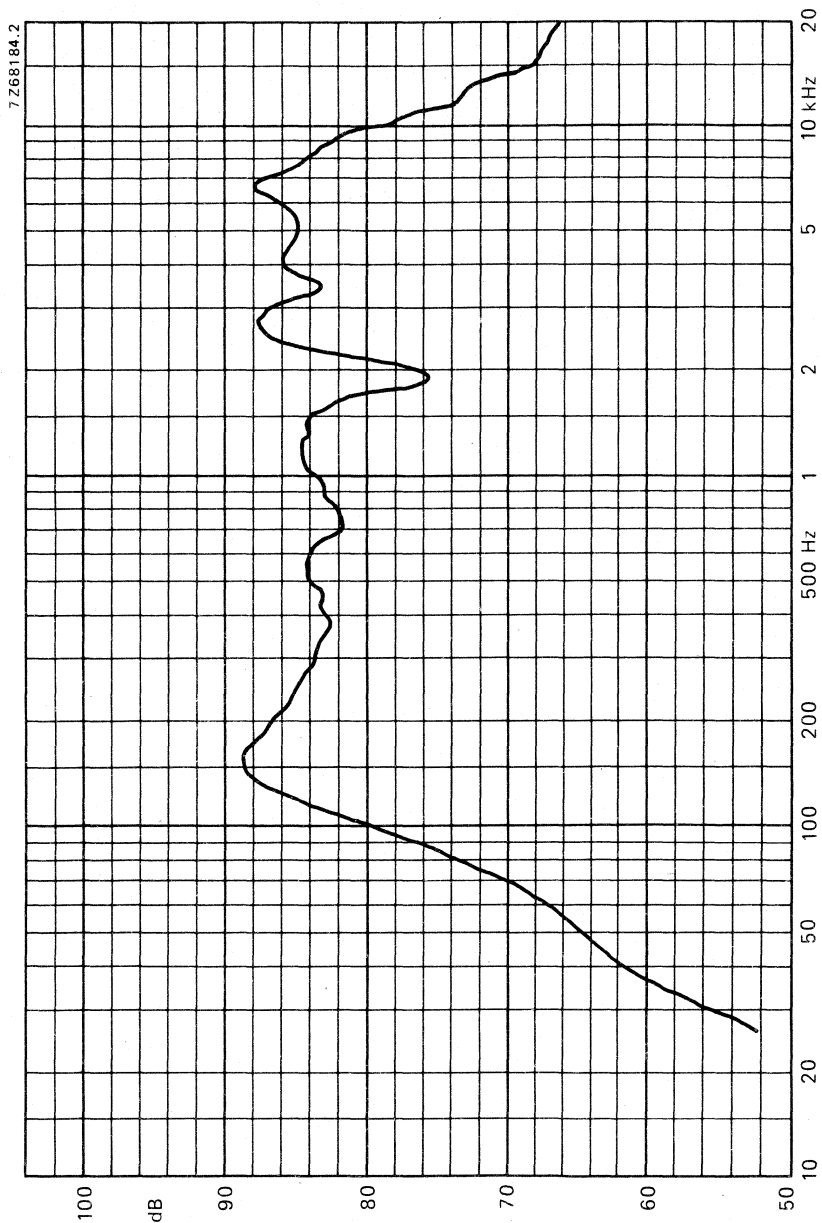

Fig. 2



3½ x 6 inch OVAL MEDIUM POWER LOUDSPEAKERS

APPLICATION

For colour television sets. Low stray field and high sensitivity.

TECHNICAL DATA

	version				
	X4	X8	X15	X25	
Rated impedance	4	8	15	25	Ω
Voice coil resistance	3,1	7,1	13,5	22,7	Ω
Rated frequency range	80 to 13 000				Hz
Resonance frequency	140				Hz
Power handling capacity, measured without filter, loudspeaker unmounted	4				W
Operating power (sound level 90 dB, 1 m)	1				W
Sweep voltage (70 to 20 000 Hz)	2,8	4	5,5	7,1	V
Energy in air gap	39				mJ
Flux density	0,8				T
Air gap height	3				mm
Voice coil height	3	3,9	3,2	4	mm
Core diameter	18				mm
Magnet material	steel alloy				
diameter	18				mm
mass	0,027				kg
Mass of loudspeaker	0,14				kg

The loudspeaker has a paper cone and surround and a foam plastic gasket. Connection to the loudspeaker by means of 2,8 mm (0,11 inch) tag connectors or by soldering.

Dimensions in mm

Baffle hole

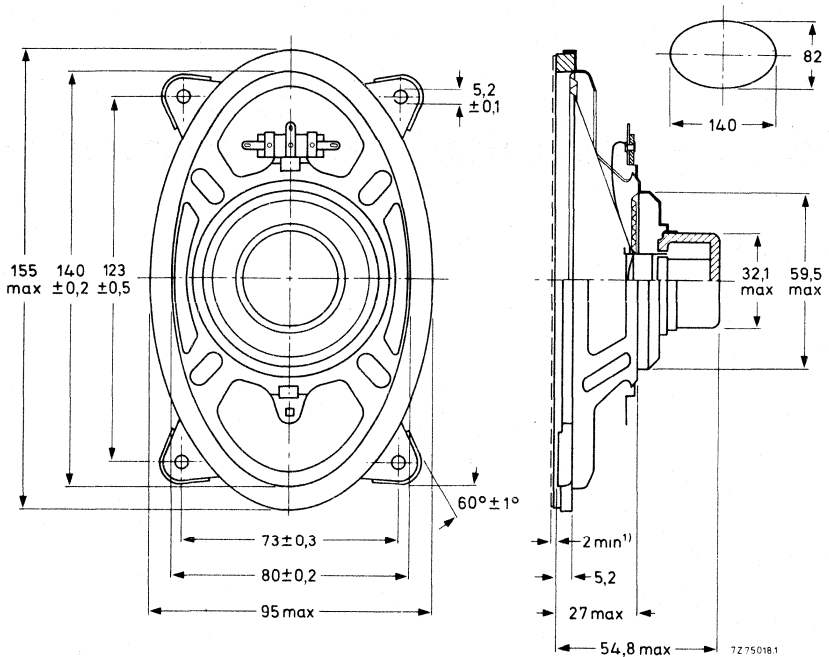

Fig. 1.

(1) Clearance depth required for cone movement at the specified power handling capacity. One tag is indicated by a red mark for in-phase connection.

→ AVAILABLE VERSIONS

AD4692/X4, catalogue number 2422 256 30821	} these numbers apply to bulk packed loudspeakers, minimum packing quantity 63 per unit.
AD4692/X8, catalogue number 2422 256 30822	
AD4692/X15, catalogue number 2422 256 30823	
AD4692/X25, catalogue number 2422 256 30824	

FREQUENCY RESPONSE CURVES (see Fig. 2)

Curve b: Sound pressure measured in anechoic room, loudspeaker mounted on baffle according to IEC 268-5, par. 4.4.

Curve c: 2nd and 3rd harmonic distortion, measured at the operating power of 1 W in anechoic room. Loudspeaker front mounted on IEC baffle.

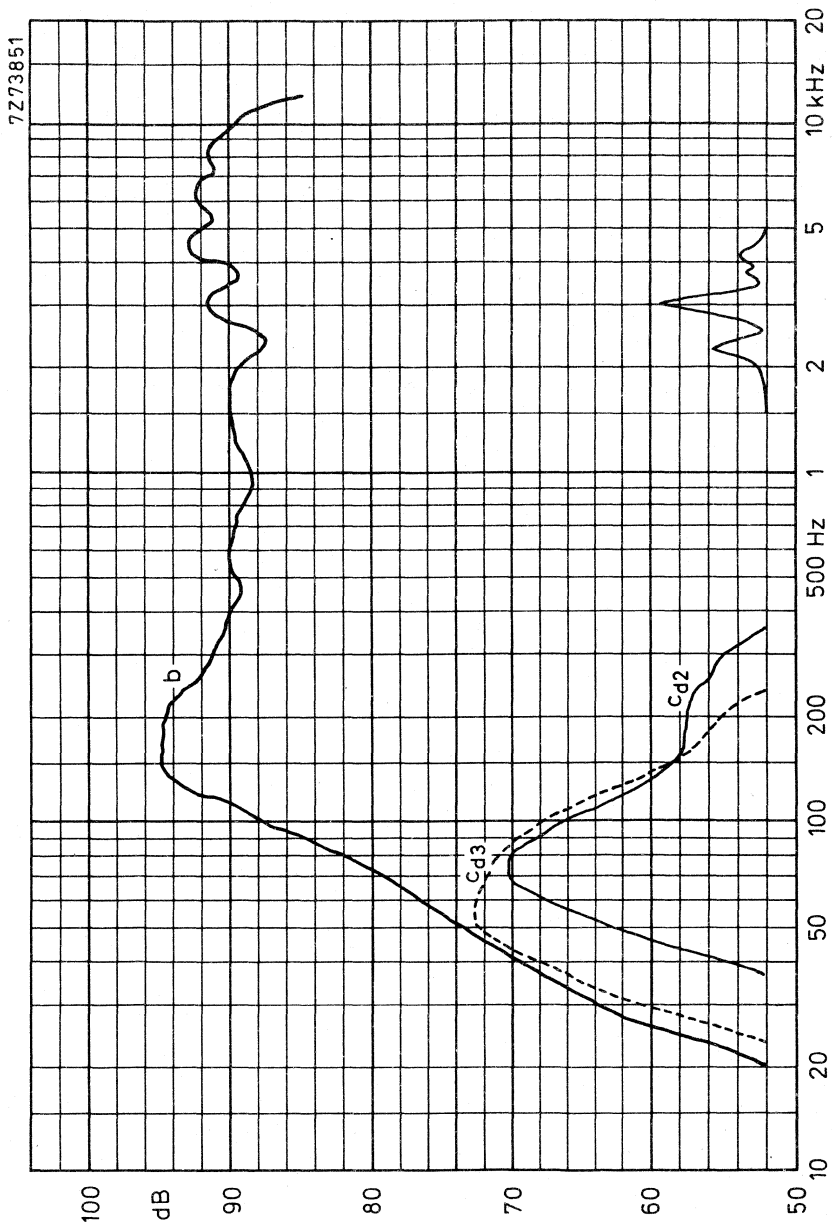

Fig. 2



4 x 6 INCH MEDIUM POWER LOUDSPEAKER

APPLICATION

A full range loudspeaker equipped with a screened and compensated ceramic magnet system for use in video systems.

TECHNICAL DATA

	version			
	X4	X8	X15	X25
Rated impedance	4	8	15	25 Ω
Voice coil resistance	3,4	7,1	13,5	22,7 Ω
Rated frequency range	70 to 12 000			Hz
Resonance frequency	140			Hz
Power handling capacity, measured without filter, loudspeaker unmounted	4			W
Operating power (sound level 90 dB, 1 m)	0,8			W
Sweep voltage (70 to 20 000 Hz)	2,8	4,0	5,5	7,1 V
Energy in air gap	65			mJ
Flux density	1,05			T
Air-gap height	3			mm
Voice coil height	4,4	3,9	3,2	4 mm
Core diameter	18			mm
Magnet material	ceramic			
diameter	45			mm
mass	0,102			kg
Mass of loudspeaker	0,315			kg

The loudspeaker has a paper cone and surround and a foam plastic gasket. Connection to the loudspeaker by means of 2,8 mm (0,11 inch) tag connectors or by soldering.

Dimensions in mm

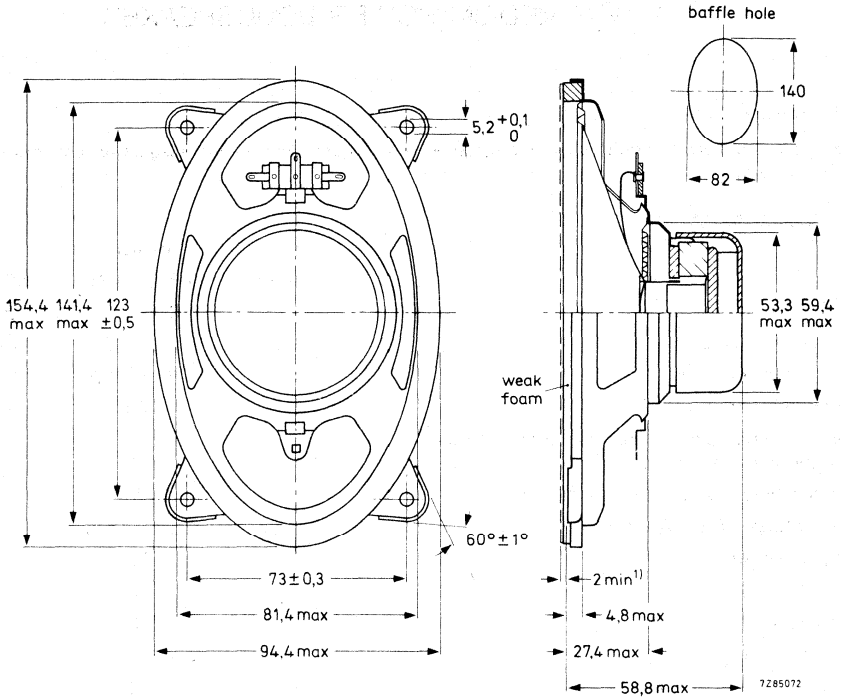

Fig. 1.

(1) Clearance depth required for cone movement at the specified power handling capacity. One tag is indicated by a red mark for in-phase connection.

→ AVAILABLE VERSIONS

AD46920/X4	catalogue number 2422 257 40021	} these numbers apply to bulk-packed loudspeakers, minimum packing quantity 63 per unit.
AD46920/X8	catalogue number 2422 257 40022	
AD46920/X15	catalogue number 2422 257 40023	
AD46920/X25	catalogue number 2422 257 40024	

FREQUENCY RESPONSE CURVES (see Fig. 2)

Measured in anechoic room at the operating power. Loudspeaker front mounted on IEC baffle.

Curve a: Sound pressure.

Curves d2 and d3: 2nd and 3rd harmonic distortion.

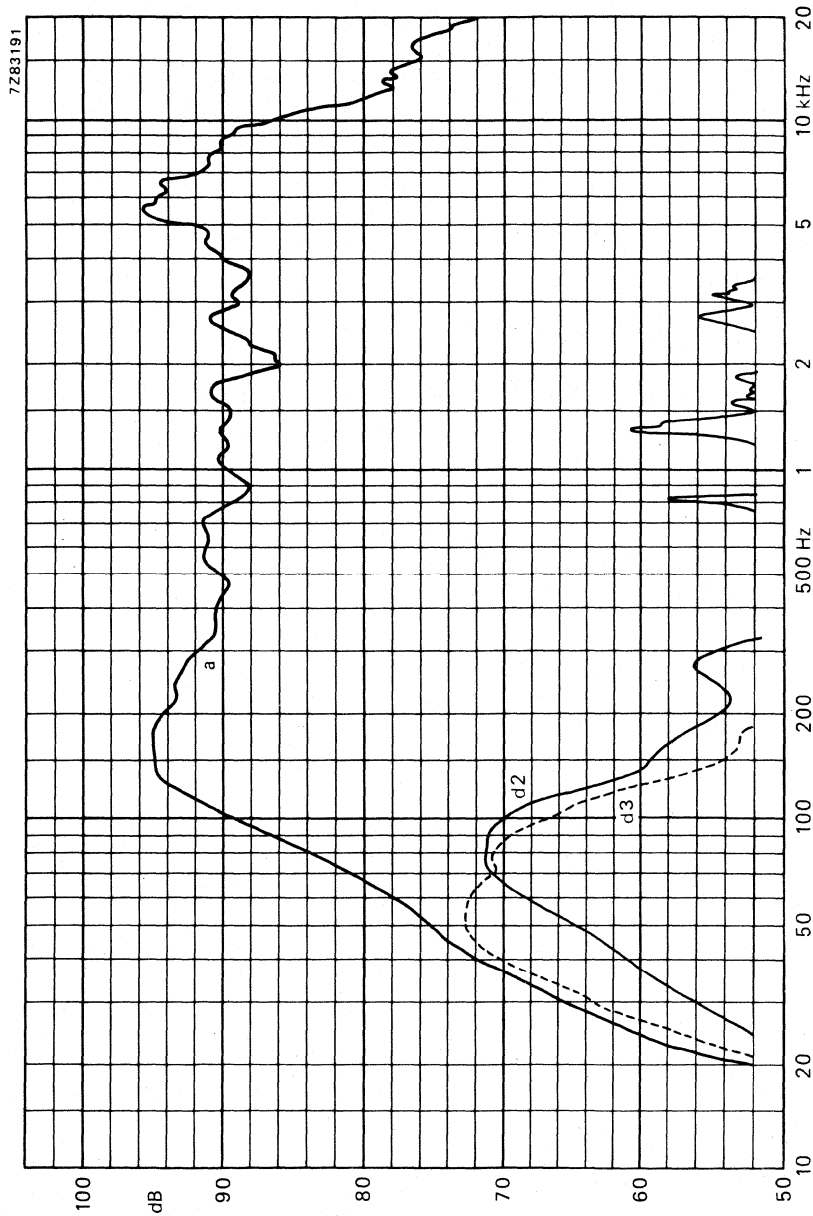

Fig. 2.



4 x 6 inch MEDIUM POWER LOUDSPEAKER

APPLICATION

The absence of stray field makes this loudspeaker very suitable for use in black and white as well as colour television sets.

High sensitivity at 3000 Hz.

TECHNICAL DATA

	version				
	X4	X8	X15	X25	
Rated impedance	4	8	15	25	Ω
Voice coil resistance	3,4	7,1	13,5	22,7	Ω
Rated frequency range	70 to 13 000				Hz
Resonance frequency	150				Hz
Power handling capacity, measured without filter, loudspeaker unmounted	4				W
Operating power (sound level 90 dB, 1 m)	1,2				W
Sweep voltage (70 to 20 000 Hz)	2,8	4,9	6,7	8,7	V
Energy in air gap	19				mJ
Flux density	0,77				T
Air-gap height	3				mm
Voice coil height	4,5	3,9	3,2	4	mm
Core diameter	14				mm
Magnet material	steel alloy				
diameter	14,5				mm
mass	0,1				kg
Mass of loudspeaker	0,26				kg

The loudspeaker has a paper cone and surround and a foam plastic gasket. Connection to the loudspeaker by means of 2,8 mm (0,11 inch) tag connectors or by soldering.

Dimensions in mm

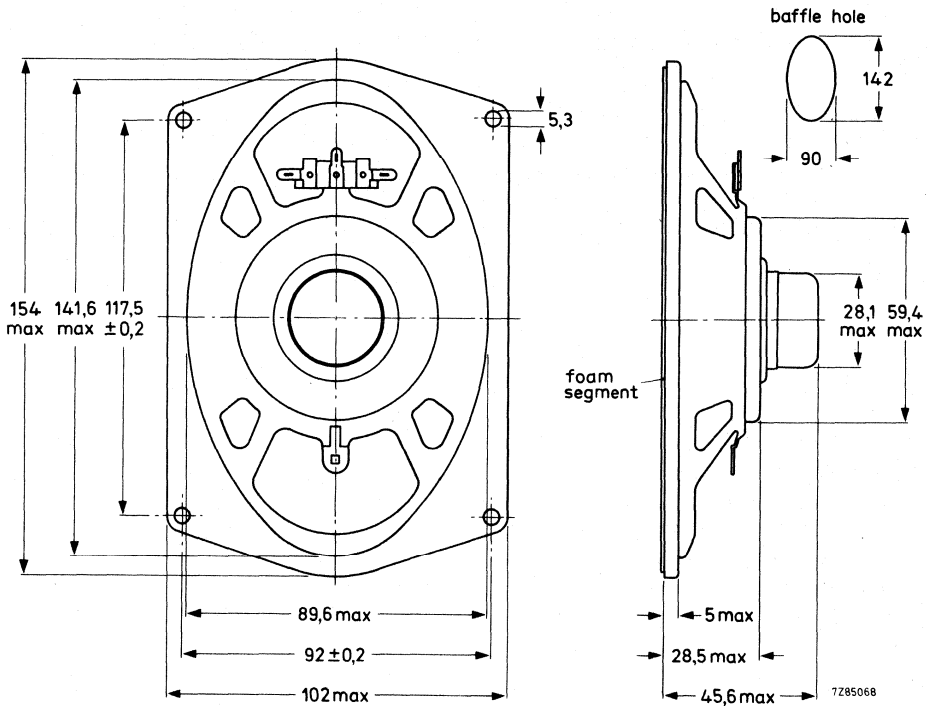

Fig. 1.

One tag is indicated by a red mark for in-phase connection.

→ AVAILABLE VERSIONS

AD4696/X4	catalogue number 2422 256 40121
AD4696/X8	catalogue number 2422 256 40122
AD4696/X15	catalogue number 2422 256 40123
AD4696/X25	catalogue number 2422 256 40124

} these numbers apply to bulk-packed loudspeakers, minimum packing quantity 63 per unit.

FREQUENCY RESPONSE CURVES (see Fig. 2)

Measured in anechoic room at the operating power. Loudspeaker front mounted on IEC baffle.

Curve a: Sound pressure.

Curves d2 and d3: 2nd and 3rd harmonic distortion.

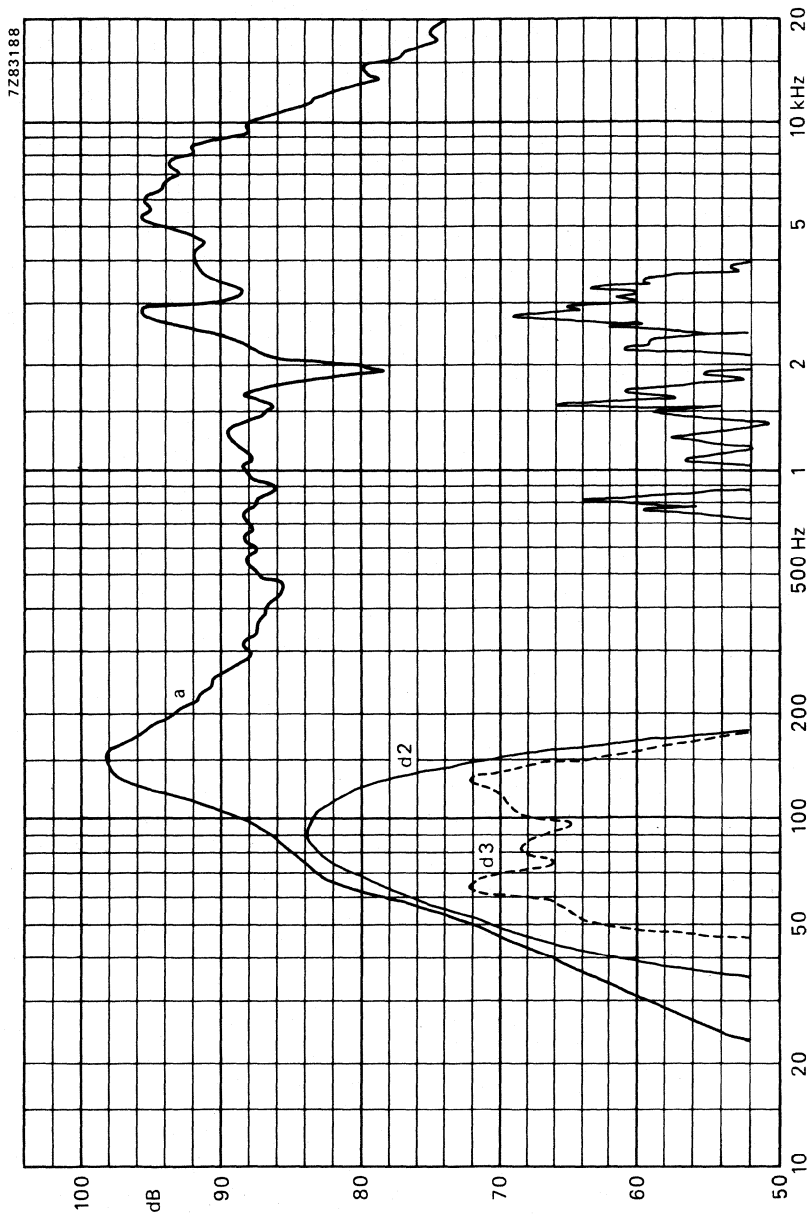

Fig. 2.



DEVELOPMENT SAMPLE DATA

This information is derived from development samples made available for evaluation. It does not necessarily imply that the device will go into regular production.

AD48900/X.

4 × 8 INCH MEDIUM POWER LOUDSPEAKER

APPLICATION

The loudspeaker can be used in black and white and colour television sets. The magnet has a screened and compensated ceramic system with a very low stray magnetic field. High sensitivity at 3000 Hz.

TECHNICAL DATA

	version			
	X4	X8	X15	X25
Rated impedance	4	8	15	25 Ω
Voice coil resistance	3,4	7,1	13,5	22,7 Ω
Rated frequency range	60 to 11 000			Hz
Resonance frequency	110			Hz
Power handling capacity, measured without filter, loudspeaker unmounted	10			W
Maximum power	15			W
Operating power	0,6	0,6	0,6	0,65 W
Sweep voltage, frequency range: 55 to 20 000 Hz	4,5	6,3	8,6	11,2 V
Energy in air gap	65			mJ
Flux density	1,045			T
Stray magnetic field according to DIN 45578 par. 2.2.5, distance 70 mm	0,35			mT
Air-gap height	3			mm
Voice coil height	4,5	4,3	3,2	4 mm
Core diameter	18			mm
Magnet material	ceramic			
diameter	53			mm
mass	0,102			kg
Mass of loudspeaker	0,365			kg

The loudspeaker has a paper cone, a treated paper surround, and a foam plastic gasket on the flange. Connection to the loudspeaker by means of 2,8 mm (0,11 inch) tag connectors or by soldering.

Dimensions in mm

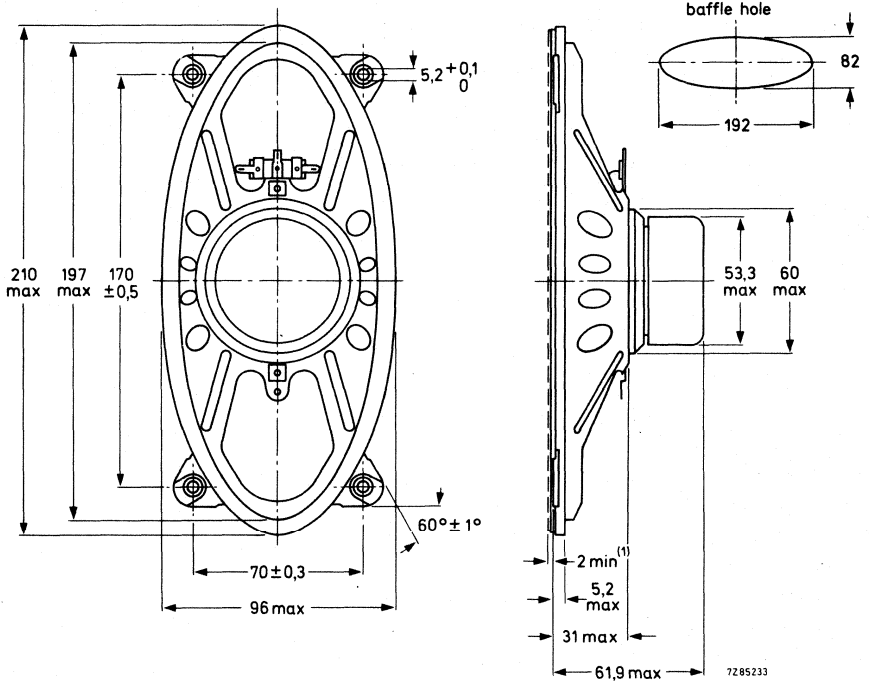

Fig. 1.

(1) Clearance depth required for cone movement at the specified power handling capacity. One tag is indicated by a red mark for in-phase connection.

AVAILABLE VERSIONS

AD48900/X4, catalogue number 2422 257 40121
 AD48900/X8, catalogue number 2422 257 40122
 AD48900/X15, catalogue number 2422 257 40123
 AD48900/X25, catalogue number 2422 257 40124

} these numbers apply to bulk packed loudspeakers, minimum packing quantity 32 per unit.

FREQUENCY RESPONSE CURVES (See Fig. 2)

Measured in anechoic room at the operating power. Loudspeaker mounted on IEC baffle according to IEC 268-5 par. 4-4.

Curve a: Sound pressure.

Curves d2 and d3: 2nd and 3rd harmonic distortion.

DEVELOPMENTAL DATA

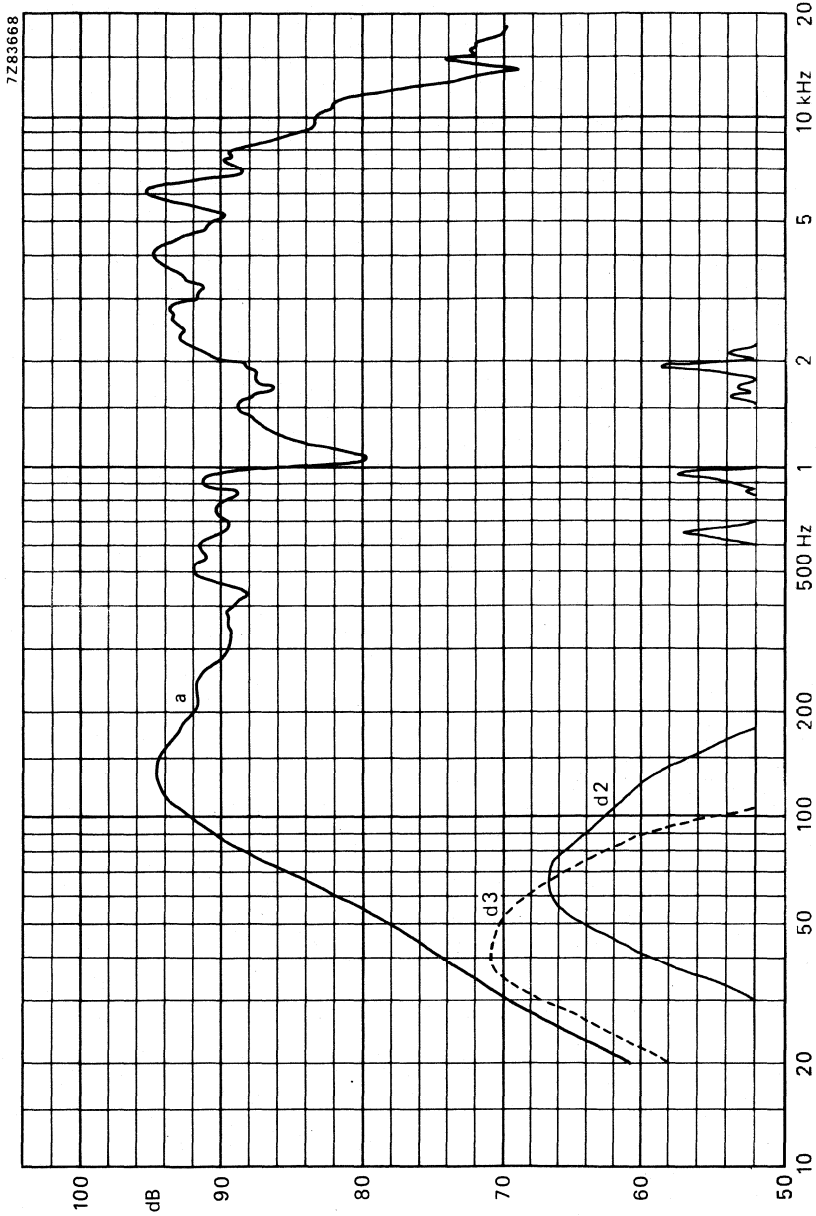

Fig. 2.



4 x 8 INCH MEDIUM POWER LOUDSPEAKER

APPLICATION

For colour television sets. Low stray field, low resonance frequency, high sensitivity in bass region.

TECHNICAL DATA

	version				
	X4	X8	X15	X25	
Rated impedance	4	8	15	25	Ω
Voice coil resistance	3,4	7,1	13,5	22,7	Ω
Rated frequency range	55 to 13 000				Hz
Resonance frequency	110				Hz
Power handling capacity, measured without filter, loudspeaker unmounted	10				W
Operating power (sound level 90 dB, 1 m)	0,8				W
Sweep voltage (55 to 20 000 Hz)	4,5	6,3	8,6	11,2	V
Energy in air gap	39				mJ
Flux density	0,8				T
Air-gap height	3				mm
Voice coil height	4,5	3,9	3,2	4	mm
Core diameter	18				mm
Magnet material	steel alloy				
diameter	18				mm
mass	0,027				kg
Mass of loudspeaker	0,23				kg

The loudspeaker has a paper cone and surround and a foam plastic gasket. Connection to the loudspeaker by means of 2,8 mm (0,11 inch) tag connectors or by soldering.

Dimensions in mm

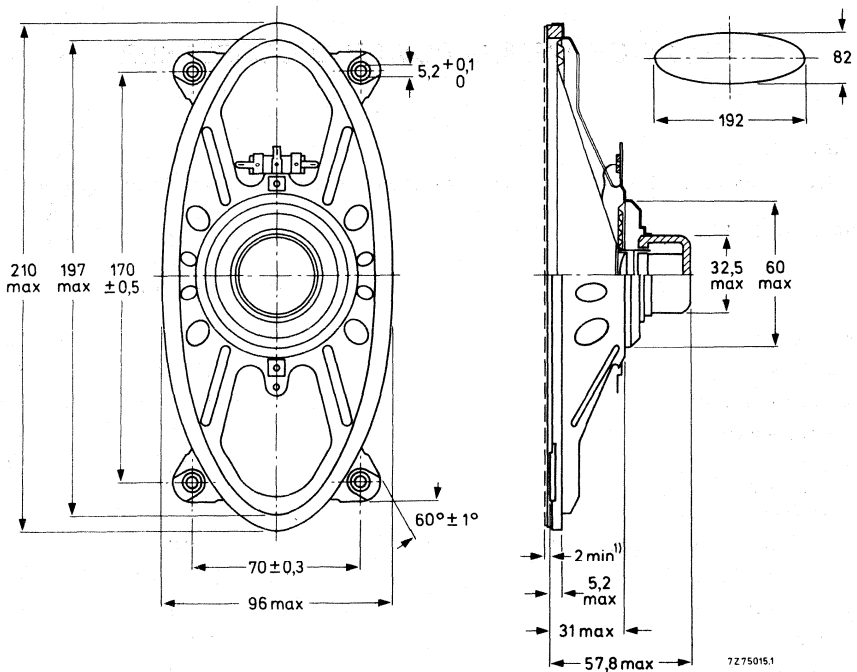

Fig. 1.

(1) Clearance depth required for cone movement at the specified power handling capacity. One tag is indicated by a red mark for in-phase connection.

→ AVAILABLE VERSIONS

- AD4891/X4, catalogue number 2422 256 30731
- AD4891/X8, catalogue number 2422 256 30732
- AD4891/X15, catalogue number 2422 256 30733
- AD4891/X25, catalogue number 2422 256 30734

these numbers apply to bulk packed loudspeakers, minimum packing quantity 32 per unit.

FREQUENCY RESPONSE CURVES (see Fig. 2)

Curve a: Sound pressure measured in anechoic room, loudspeaker mounted on baffle according to IEC 268-5.

Curves d2 and d3: 2nd and 3rd harmonic distortion, measured at the operating power of 0,8 W in anechoic room. Loudspeaker front mounted on IEC baffle.

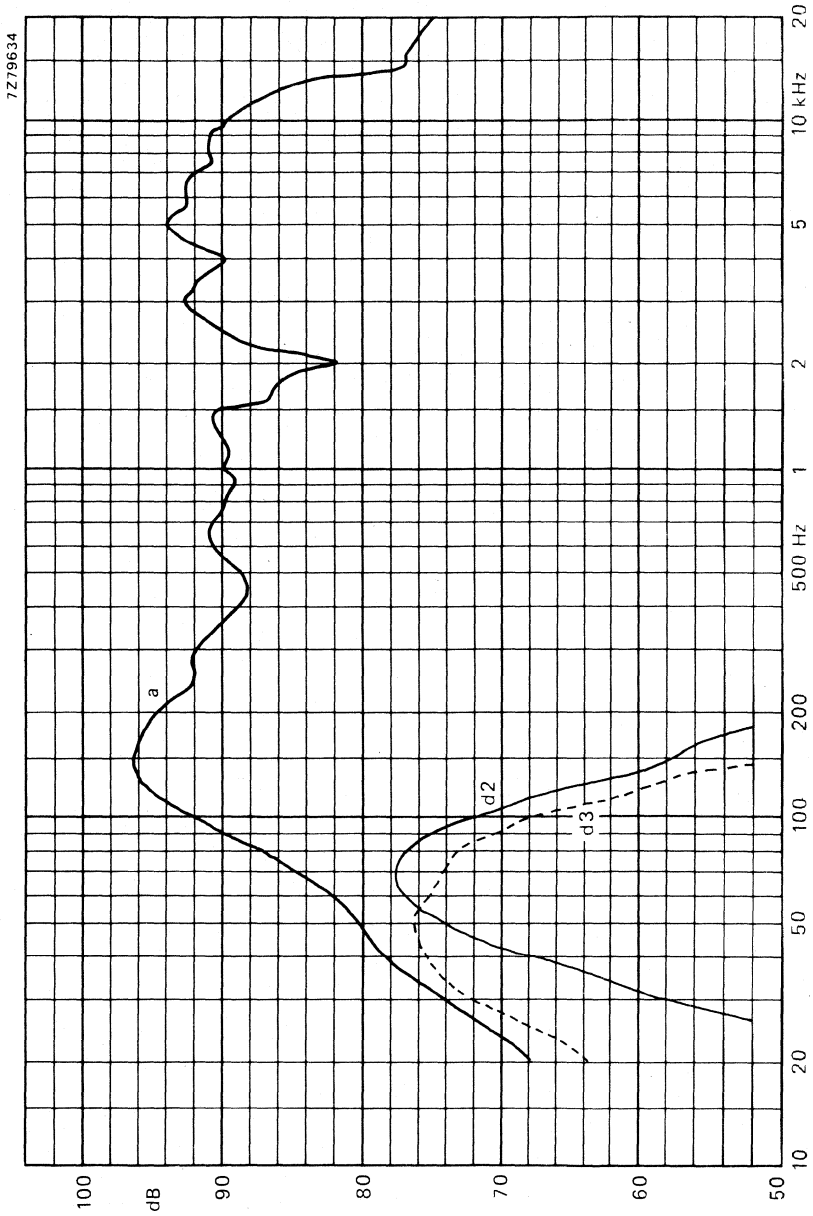

Fig. 2.



5 inch ROUND MEDIUM POWER LOUDSPEAKERS

APPLICATION

Dual cone loudspeaker for car and domestic radios, tape recorders, portable record players and intercoms.

TECHNICAL DATA

	version				
	M4	M8	M15	M25	
Rated impedance	4	8	15	25	Ω
Voice coil resistance	3,4	7,1	13,5	22,7	Ω
Rated frequency range	70 to 20 000				Hz
Resonance frequency	135				Hz
Power handling capacity, measured without filter, loudspeaker unmounted	6				W
Operating power (sound level 90 dB, 1 m)	0,7				W
Sweep voltage (70 to 20 000 Hz)	3,5	4,9	6,7	8,7	V
Energy in air gap	55				mJ
Flux density	1				T
Air-gap height	3				mm
Voice coil height	4,4	3,6	3,2	4	mm
Core diameter	18				mm
Magnet material	ceramic				
diameter	53				mm
mass	0,1				kg
Mass of loudspeaker	0,25				kg

The loudspeaker has a paper dual cone and surround, and a foam plastic gasket on the flange. Connection to the loudspeaker by means of 2,8 mm (0,11 inch) tag connectors or by soldering.

Dimensions in mm

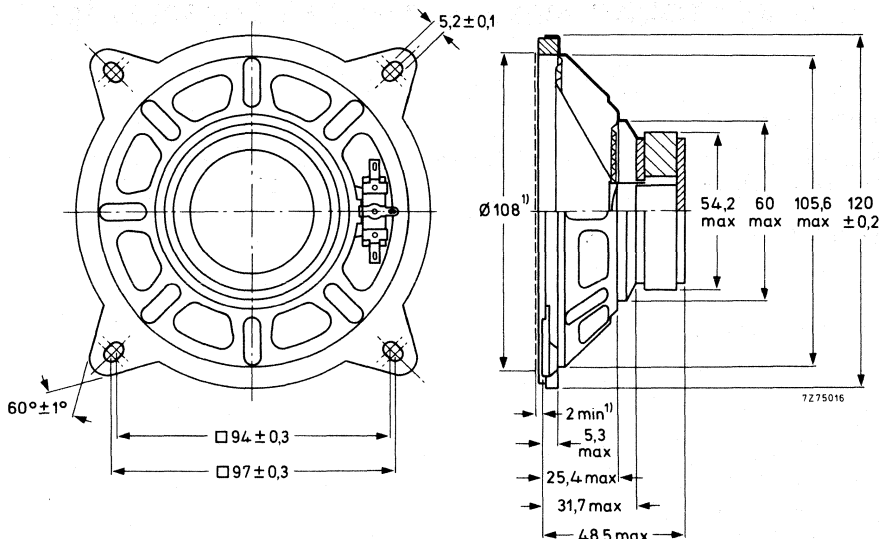

Fig. 1.

(1) Baffle hole and clearance depth required for cone movement at the specified power handling capacity. One tag is indicated by a red mark for in-phase connection.

→ AVAILABLE VERSIONS

- AD5081/M4, catalogue number 2422 257 35725
- AD5081/M8, catalogue number 2422 257 35726
- AD5081/M15, catalogue number 2422 257 35727
- AD5081/M25, catalogue number 2422 257 35728

} these numbers apply to bulk packed loudspeakers, minimum packing quantity 32 per unit.

FREQUENCY RESPONSE CURVE (see Fig. 2)

Input power 50 mW. Sound pressure measured in anechoic room, loudspeaker mounted on baffle according to IEC 268-5, par. 4.4.

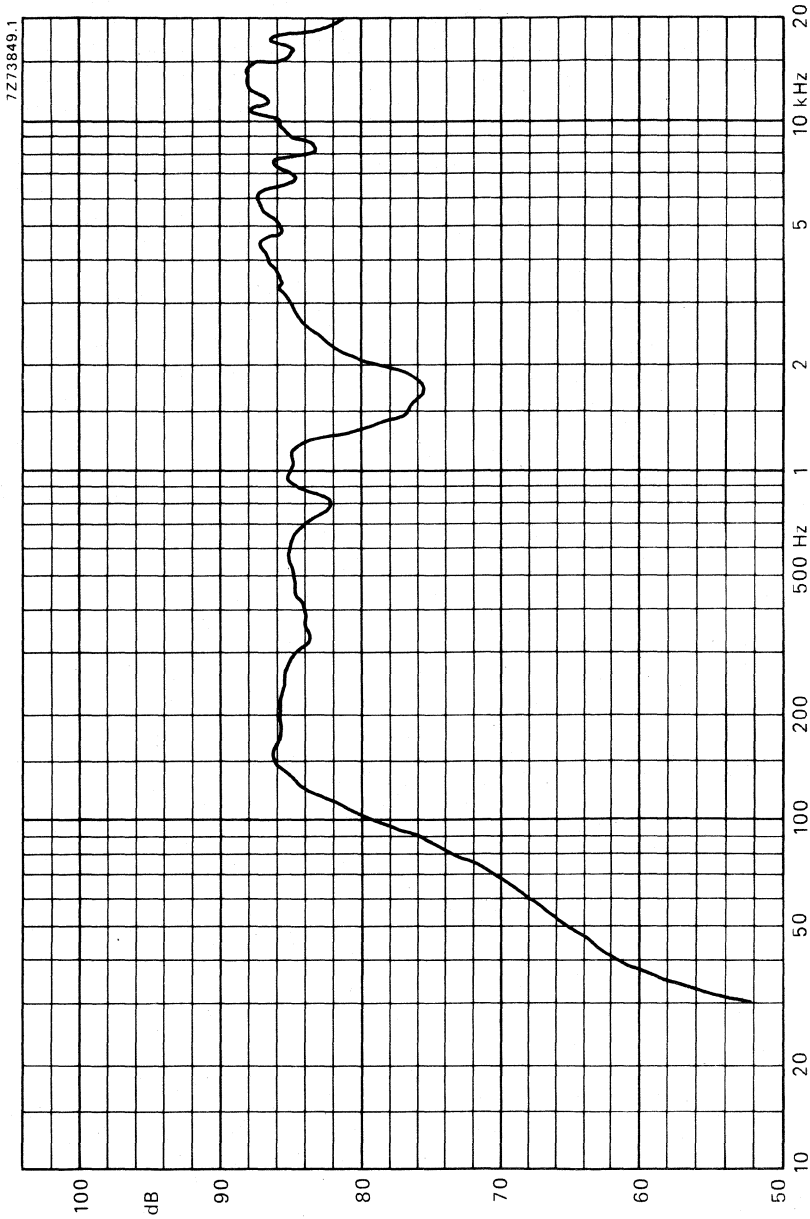

Fig. 2



5 inch ROUND MEDIUM POWER LOUDSPEAKER

APPLICATION

For car and domestic radios, tape recorders, portable record players and intercoms.

TECHNICAL DATA

	version				
	X4	X8	X15	X25	
Rated impedance	4	8	15	25	Ω
Voice coil resistance	3,4	7,1	13,5	22,7	Ω
Rated frequency range	60 to 14 000				Hz
Resonance frequency	140				Hz
Power handling capacity, measured without filter, loudspeaker unmounted	6				W
Operating power (sound level 90 dB, 1 m)	0,7				W
Sweep voltage (70 to 20 000 Hz)	3,5	4,9	6,7	8,7	V
Energy in air gap	55				mJ
Flux density	1				T
Air-gap height	3				mm
Voice coil height	4,4	3,9	3,2	4	mm
Core diameter	18				mm
Magnet material	ceramic				
diameter	53				mm
mass	0,1				kg
Mass of loudspeaker	0,25				kg

The loudspeaker has a paper cone and surround and a foam plastic gasket. Connection to the loudspeaker by means of 2,8 mm (0,11 inch) tag connectors or by soldering. ←

Dimensions in mm

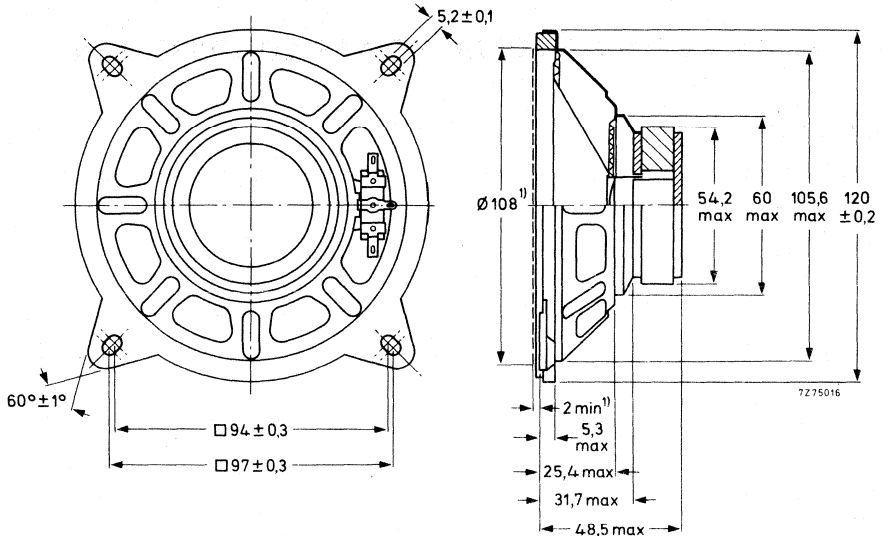

Fig. 1.

(1) Baffle hole and clearance depth required for cone movement at the specified power handling capacity. One tag is indicated by a red mark for in-phase connection.

→ AVAILABLE VERSIONS

- AD5081/X4, catalogue number 2422 257 35721
- AD5081/X8, catalogue number 2422 257 35722
- AD5081/X15, catalogue number 2422 257 35723
- AD5081/X25, catalogue number 2422 257 35724

these numbers apply to bulk packed loudspeakers, minimum packing quantity 32 per unit.

FREQUENCY RESPONSE CURVE (see Fig. 2)

Input power 50 mW. Sound pressure measured in anechoic room, loudspeaker mounted on baffle according to IEC 268-5, par. 4.4.

5 inch ROUND MEDIUM POWER
LOUDSPEAKERS

AD5081/X.

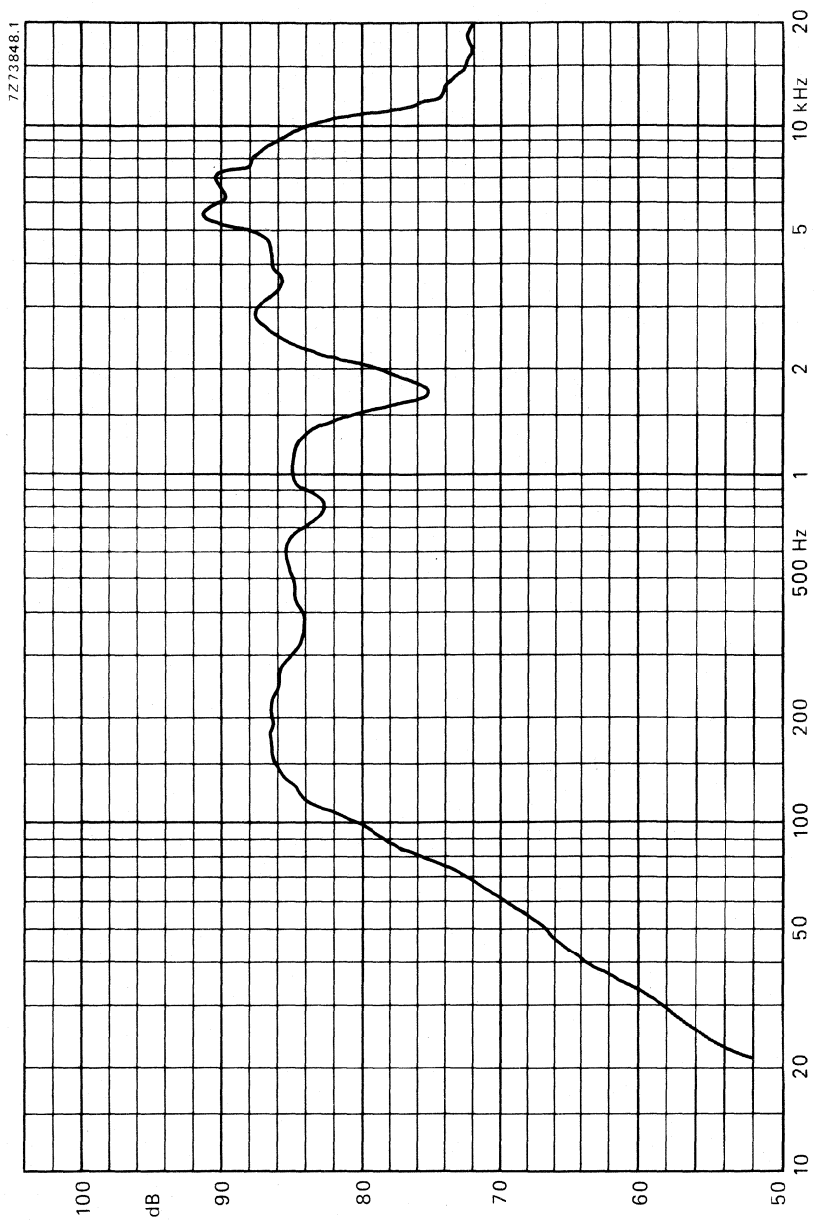

Fig. 2



5 × 7 inch OVAL MEDIUM POWER LOUDSPEAKER

APPLICATION

A full range loudspeaker for car and domestic radios, tape recorders and portable record players.

This loudspeaker has an extended frequency response up to 20 kHz due to its dual-cone construction.

TECHNICAL DATA

	version				
	M4	M8	M15	M25	
Rated impedance	4	8	15	25	Ω
Voice coil resistance	3,4	7,1	13,5	22,7	Ω
Resonance frequency	100	100	100	100	Hz
Power handling capacity, measured without filter loudspeaker unmounted	6	6	6	6	W
Sweep voltage	2,8	4	5,5	8,7	V
Energy in air gap	53	53	53	53	mJ
Flux density	0,98	0,98	0,98	0,98	T
Air-gap height	3	3	3	3	mm
Voice coil height	4,5	3,9	3,2	4	mm
Core diameter	18	18	18	18	mm
Magnet material	ceramic	ceramic	ceramic	ceramic	
diameter	53	53	53	53	mm
mass	0,1	0,1	0,1	0,1	kg
Mass of loudspeaker	0,32	0,32	0,32	0,32	kg

The loudspeaker has a paper dual cone and surround, and a foam plastic gasket on the flange. Connection to the loudspeaker by means of 2,8 mm (0,11 inch) tag connectors or by soldering.



Dimensions in mm

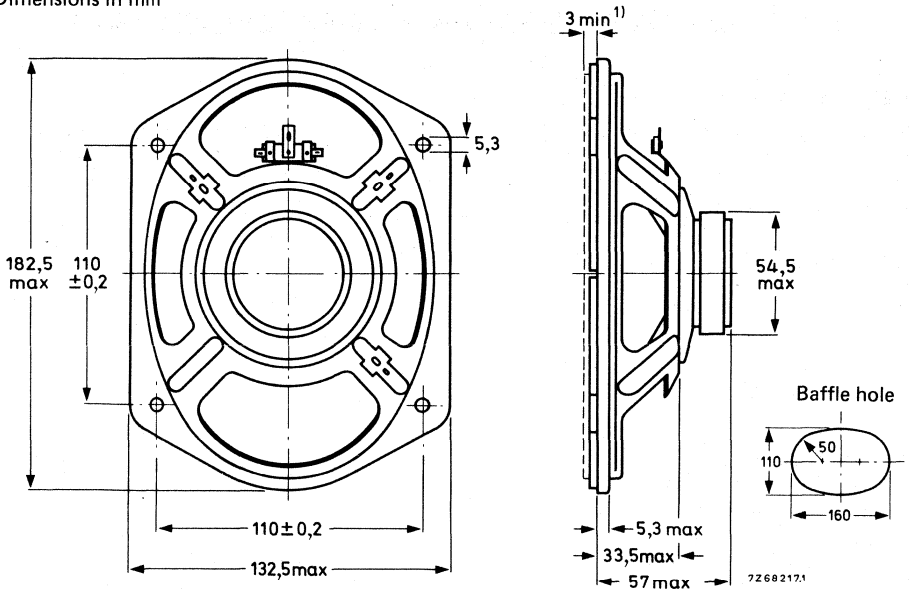

Fig. 1.

(1) Clearance depth required for cone movement at the specified power handling capacity. One tag is indicated by a red mark for in-phase connection.

→ AVAILABLE VERSIONS

- AD5780/M4, catalogue number 2422 257 36125
- AD5780/M8, catalogue number 2422 257 36126
- AD5780/M15, catalogue number 2422 257 36127
- AD5780/M25, catalogue number 2422 257 36128

} these numbers apply to bulk packed loudspeakers, minimum packing quantity 32 per unit.

FREQUENCY RESPONSE CURVE

Fig. 2. Input power 50 mW. Sound pressure measured in anechoic room, loudspeaker mounted on IEC baffle.

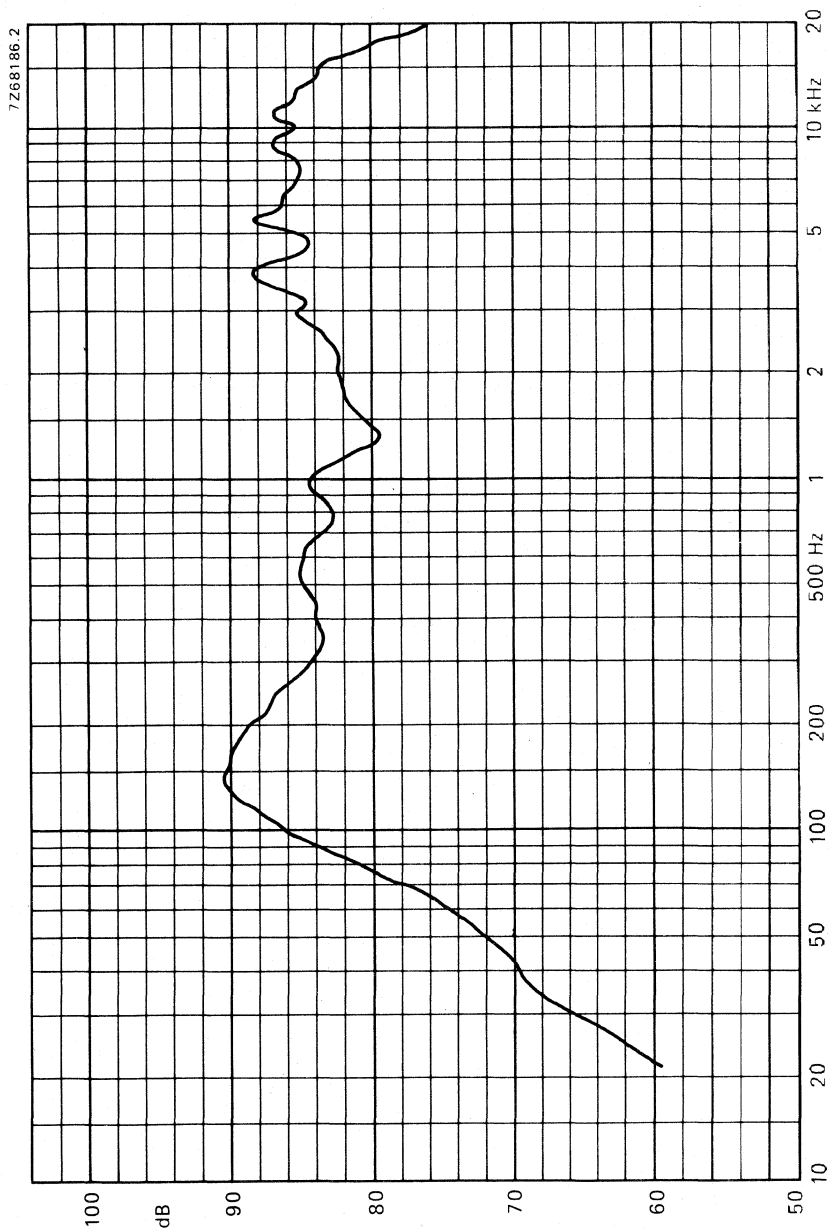

Fig. 2



5 × 7 inch OVAL MEDIUM POWER LOUDSPEAKER

APPLICATION

For car and domestic radios, tape recorders and portable record players.
High sensitivity at 4000 Hz. Frequency range up to 10 kHz.

TECHNICAL DATA

	version				
	X4	X8	X15	X25	
Rated impedance	4	8	15	25	Ω
Voice coil resistance	3,4	7,1	13,5	22,7	Ω
Resonance frequency	115	115	115	115	Hz
Power handling capacity, measured without filter, loudspeaker unmounted	6	6	6	6	W
Sweep voltage	3,4	3,5	4,8	6,1	V
Energy in airgap	55	55	55	55	mJ
Flux density	0,98	0,98	0,98	0,98	T
Airgap height	3	3	3	3	mm
Voice coil height	4,5	3,9	3,2	4	mm
Core diameter	18	18	18	18	mm
Magnet material	ceramic	ceramic	ceramic	ceramic	
diameter	53	53	53	53	mm
mass	0,1	0,1	0,1	0,1	kg
Mass of loudspeaker	0,32	0,32	0,32	0,32	kg

The loudspeaker has a paper cone and surround, and a foam plastic gasket on the flange.
Connection to the loudspeaker by 2,8 mm (0,11 inch) tag connectors or by soldering.

Dimensions in mm

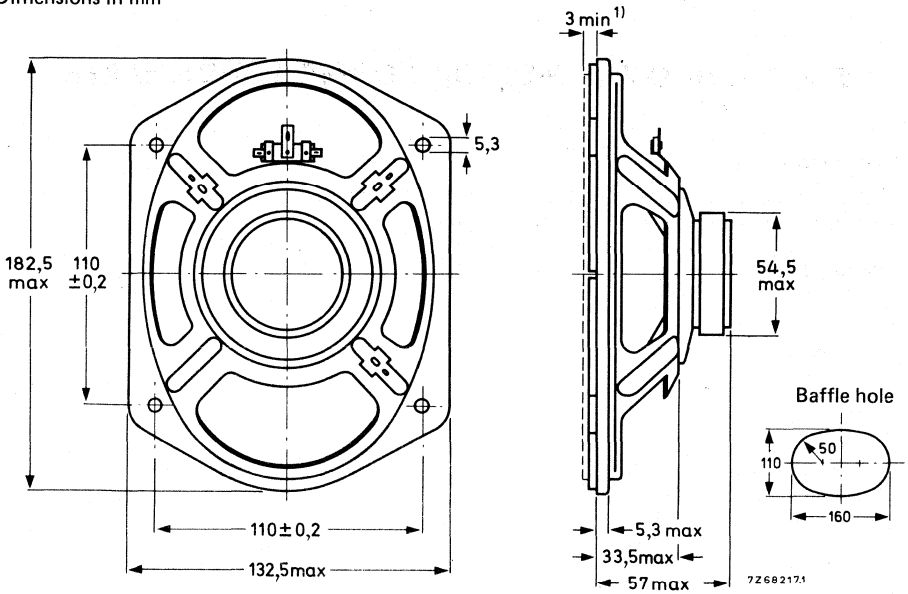

Fig. 1.

(1) Clearance depth required for cone movement at the specified power handling capacity. One tag is indicated by a red mark for in-phase connection.

→ AVAILABLE VERSIONS

- AD5780/X4, catalogue number 2422 257 36121
- AD5780/X8, catalogue number 2422 257 36122
- AD5780/X15, catalogue number 2422 257 36123
- AD5780/X25, catalogue number 2422 257 36124

} these numbers apply to bulk packed loudspeakers, minimum packing quantity 32 per unit.

FREQUENCY RESPONSE CURVE

Fig. 2. Input power 50 mW. Sound pressure measured in anechoic room, loudspeaker mounted on IEC baffle.

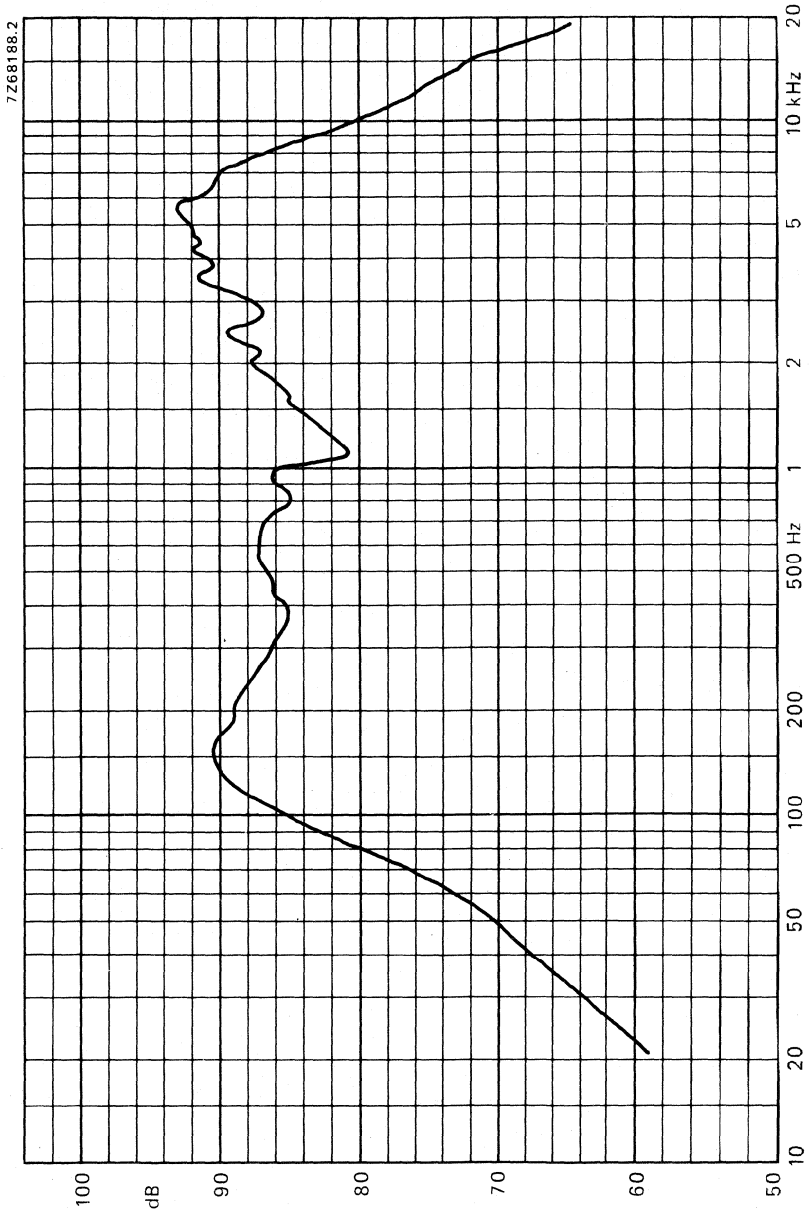

Fig.2



DEVELOPMENT SAMPLE DATA

This information is derived from development samples made available for evaluation. It does not necessarily imply that the device will go into regular production.

AD57900/X.

5 × 7 INCH MEDIUM POWER LOUDSPEAKER

APPLICATION

The loudspeaker can be used in black and white and colour television sets. The magnet has a screened and compensated ceramic system with a very low stray magnetic field. High sensitivity at 3000 Hz.

TECHNICAL DATA

	version	
	X4	X8
Rated impedance	4	8 Ω
Voice coil resistance	3,4	7,1 Ω
Rated frequency range	55 to 12 000 Hz	
Resonance frequency	100	105 Hz
Power handling capacity, measured without filter, loudspeaker unmounted	10	W
Maximum power	15	W
Operating power	0,7	0,45 W
Sweep voltage, frequency range: 55 to 22 000 Hz	4,5	6,3 V
Energy in air gap	65	mJ
Flux density	1,045	T
Stray magnetic field according to DIN 45578 par. 2.2.5, distance 70 mm	0,35	mT
Air-gap height	3	mm
Voice coil height	4,5	4,3 mm
Core diameter	18	mm
Magnet material	ceramic	
diameter	53	mm
mass	0,102	kg
Mass of loudspeaker	0,346	kg

The loudspeaker has a paper cone, a treated paper surround, and a foam plastic gasket on the flange. Connection to the loudspeaker by means of 2,8 mm (0,11 inch) tag connectors or by soldering.

Dimensions in mm

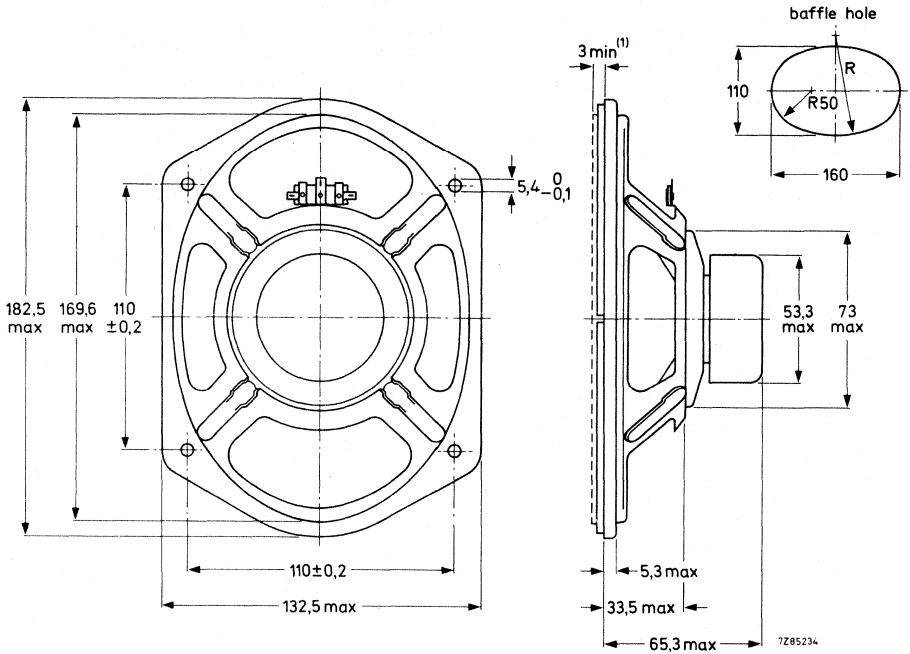

Fig. 1.

(1) Clearance depth required for cone movement at the specified power handling capacity. One tag is indicated by a red mark for in-phase connection.

AVAILABLE VERSIONS

AD57900/X4 catalogue number 2422 257 36221
 AD57900/X8 catalogue number 2422 257 36222

these numbers apply to bulk packed loudspeakers, minimum packing quantity 28 per unit.

FREQUENCY RESPONSE CURVES (See Fig. 2)

Measured in anechoic room at the operating power. Loudspeaker mounted on IEC baffle according to IEC 268-5 par. 4-4.

Curve a: Sound pressure.

Curves d2 and d3: 2nd and 3rd harmonic distortion.

DEVELOPMENT SAMPLE DATA

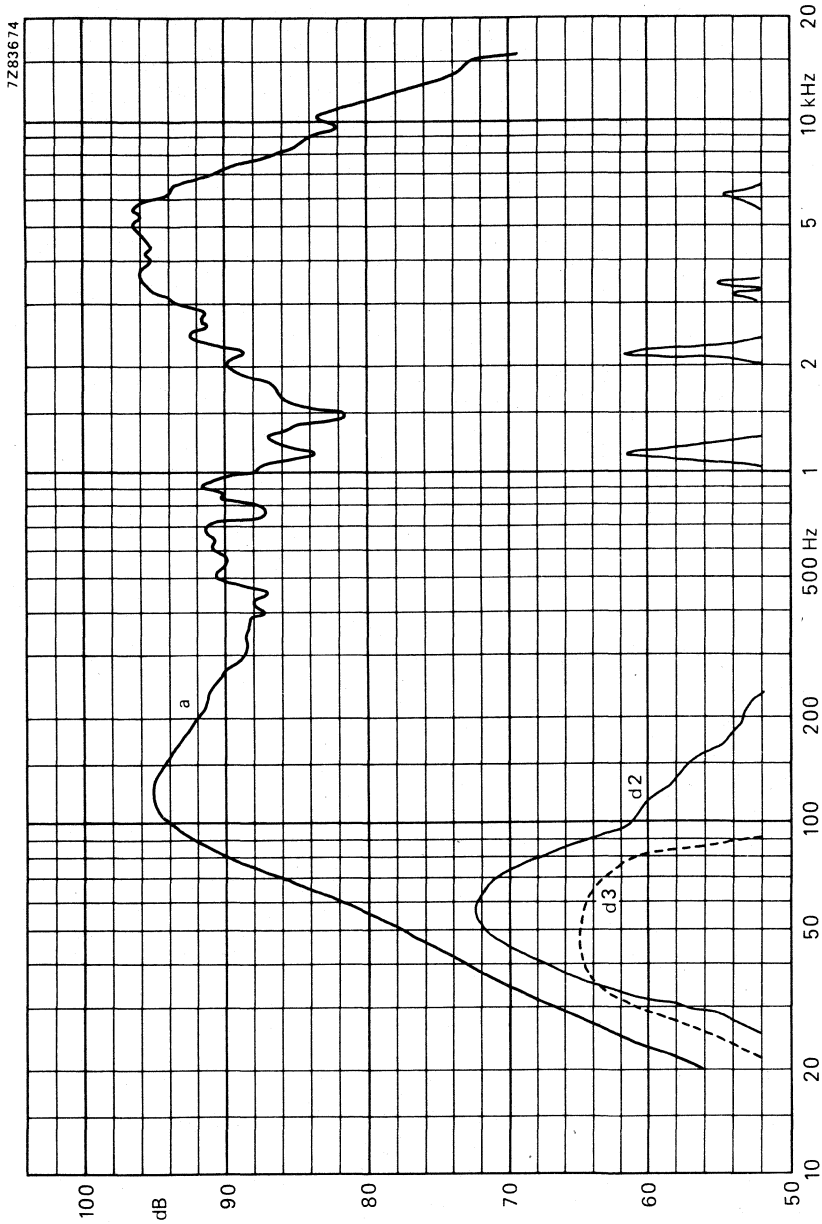

Fig. 2.



5 x 7 inch OVAL MEDIUM POWER LOUDSPEAKER

APPLICATION

The absence of stray field makes this loudspeaker very suitable for use in black and white as well as colour television sets. High sensitivity at 3000 Hz.

TECHNICAL DATA

	version	
	M4	M8
Rated impedance	4	8 Ω
Voice coil resistance	3,4	7,1 Ω
Resonance frequency	100	Hz
Power handling capacity, measured without filter, loudspeaker unmounted	10	W
Operating power (sound level 90 dB, 1 m)	1,2	W
Sweep voltage (50 to 20 000 Hz)	4,5	6,3 V
Energy in air gap	39	mJ
Flux density	0,8	T
Air-gap height	3	mm
Voice coil height	3,9	mm
Core diameter	18	mm
Magnet material	steel alloy	
diameter	18	mm
mass	0,027	kg
Mass of loudspeaker	0,22	kg

The loudspeaker has a paper dual cone and surround, and a foam plastic gasket on the flange. Connection to the loudspeaker by means of 2,8 mm (0,11 inch) tag connectors or by soldering.

Dimensions in mm

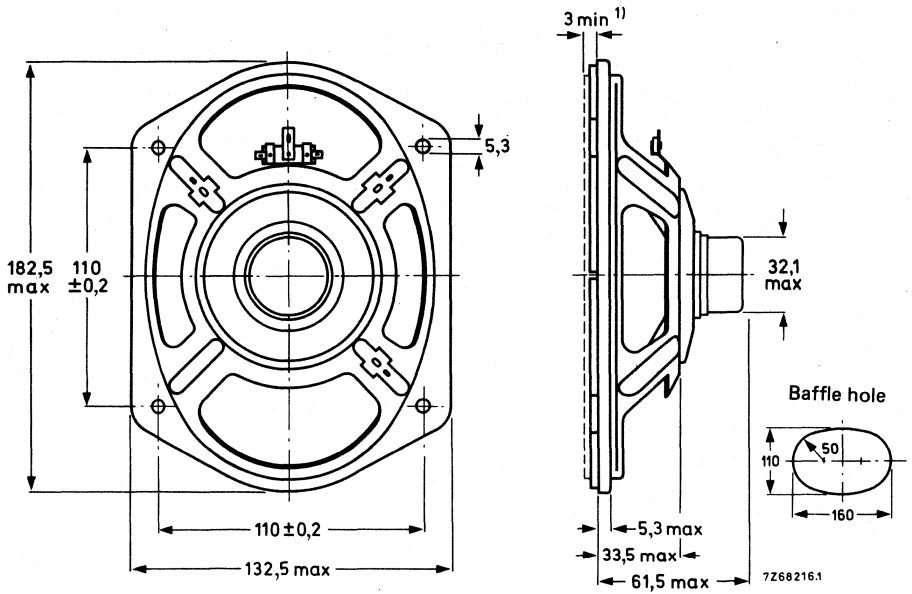

Fig. 1.

(1) Clearance depth required for cone movement at the specified power handling capacity. One tag is indicated by a red mark for in-phase connection.

→ AVAILABLE VERSIONS

AD5791/M4, catalogue number 2422 256 36031
 AD5791/M8, catalogue number 2422 256 36032

} these numbers apply to bulk packed loudspeakers, minimum packing quantity 28 per unit.

FREQUENCY RESPONSE CURVES (Fig. 2)

Measured in anechoic room at the operating power. Loudspeaker mounted on IEC baffle.

Curve a: Sound pressure.

Curves d2 and d3: 2nd and 3rd harmonic distortion.

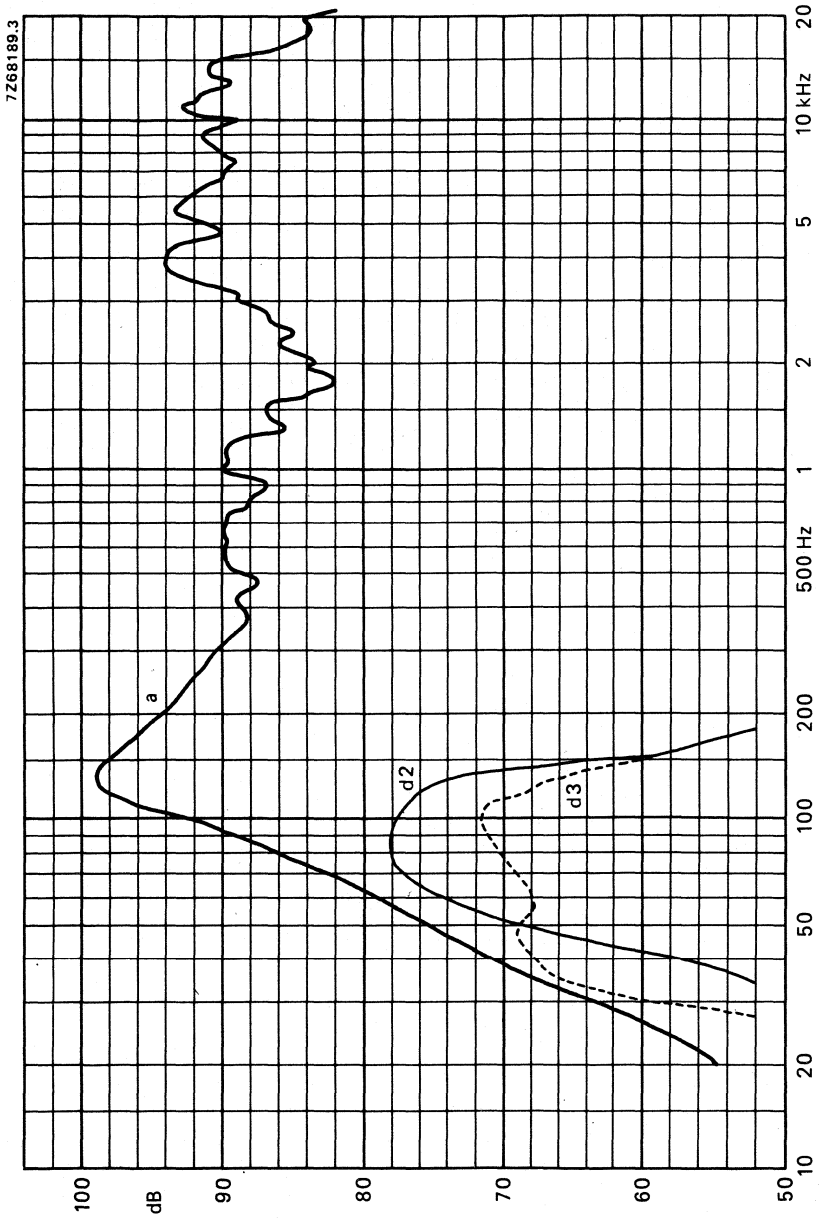

Fig. 2.



7 inch OCTAGONAL MEDIUM POWER LOUDSPEAKER

APPLICATION

For car and domestic radios, acoustic enclosures and public address systems.
Frequency range up to 15 kHz.

TECHNICAL DATA

	version			
	M4	M8	M15	
Rated impedance	4	8	15	Ω
Voice coil resistance	3,4	7,1	13,5	Ω
Resonance frequency	105	105	105	Hz
Power handling capacity, measured without filter loudspeaker unmounted	6	6	6	W
Sweep voltage	2,8	4	6,7	V
Energy in airgap	55	55	53	mJ
Flux density	0,98	0,98	0,98	T
Airgap height	3	3	3	mm
Voice coil height	4,5	3,9	3,2	mm
Core diameter	18	18	18	mm
Magnet material	ceramic	ceramic	ceramic	
diameter	53	53	53	mm
mass	0,1	0,1	0,1	kg
Mass of loudspeaker	0,29	0,29	0,29	kg

The loudspeaker has a paper dual cone and surround, and a foam plastic gasket on the flange. Connection to the loudspeaker by means of 2,8 mm (0,11 inch) tag connectors or by soldering.

Dimensions in mm

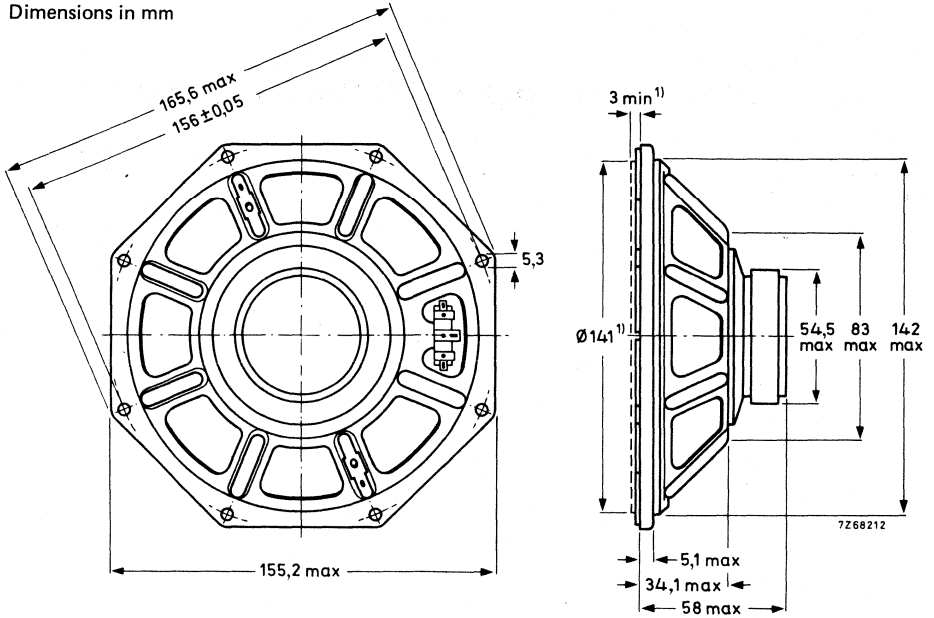

Fig. 1.

(1) Baffle hole and clearance depth required for cone movement at the specified power handling capacity. One tag is indicated by a red mark for in-phase connection.

→ AVAILABLE VERSIONS

- AD7080/M4, catalogue number 2422 257 37823
- AD7080/M8, catalogue number 2422 257 37824
- AD7080/M15, catalogue number 2422 257 37825

these numbers apply to bulk packed loudspeakers, minimum packing quantity 32 per unit.

FREQUENCY RESPONSE CURVE

Fig. 2. Input power 50 mW. Sound pressure measured in anechoic room, loudspeaker mounted on IEC baffle.

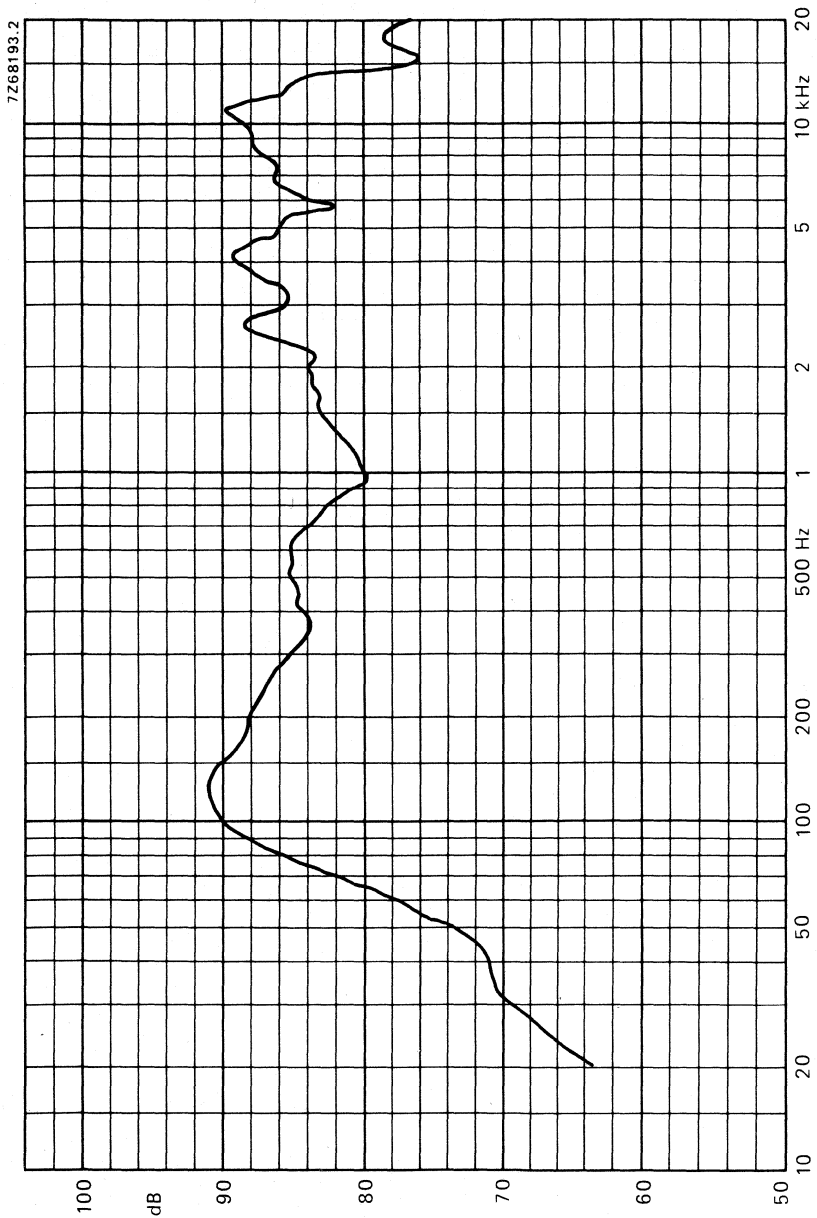

Fig. 2



7 inch OCTAGONAL MEDIUM POWER LOUDSPEAKER

APPLICATION

For car and domestic radios and accoustic enclosures.
High sensitivity at 4000 Hz.

TECHNICAL DATA

	version	
	X4	X8
Rated impedance	4	8 Ω
Voice coil resistance	3,4	7,1 Ω
Resonance frequency		115 Hz
Power handling capacity, measured without filter loudspeaker unmounted		6 W
Operating power (sound level 90 dB, 1 m)		0,6 W
Sweep voltage	3,5	4,9 V
Energy air gap		55 mJ
Flux density		0,98 T
Air-gap height		3 mm
Voice coil height		3,9 mm
Core diameter		18 mm
Magnet material		ceramic
diameter		53 mm
mass		0,1 kg
Mass of loudspeaker		0,29 kg

The loudspeaker has a paper cone and surround, and a foam plastic gasket on the flange. Connection to the loudspeaker by means of 2,8 mm (0,11 inch) tag connectors or by soldering.

Dimensions in mm

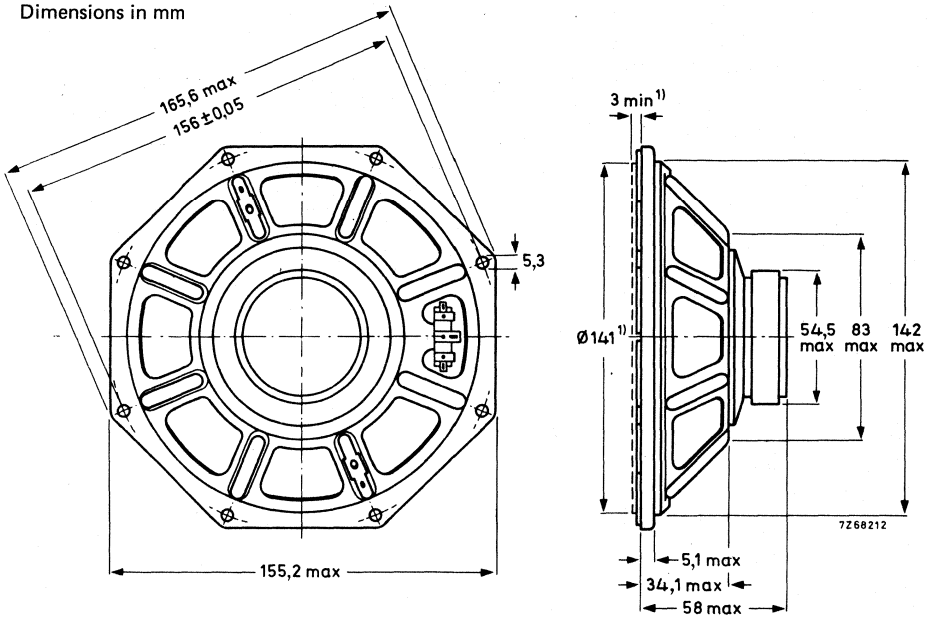

Fig. 1.

(1) Baffle hole and clearance depth required for cone movement at the specified power handling capacity. One tag is indicated by a red mark for on-phase connection.

→ AVAILABLE VERSIONS

AD7080/X4, catalogue number 2422 257 37821
 AD7080/X8, catalogue number 2422 257 37822

} these numbers apply to bulk packed loudspeakers, minimum packing quantity 32 per unit.

FREQUENCY RESPONSE CURVE

Fig. 2. Input power 50 mW. Sound pressure measured in anechoic room, loudspeaker is mounted on IEC baffle.

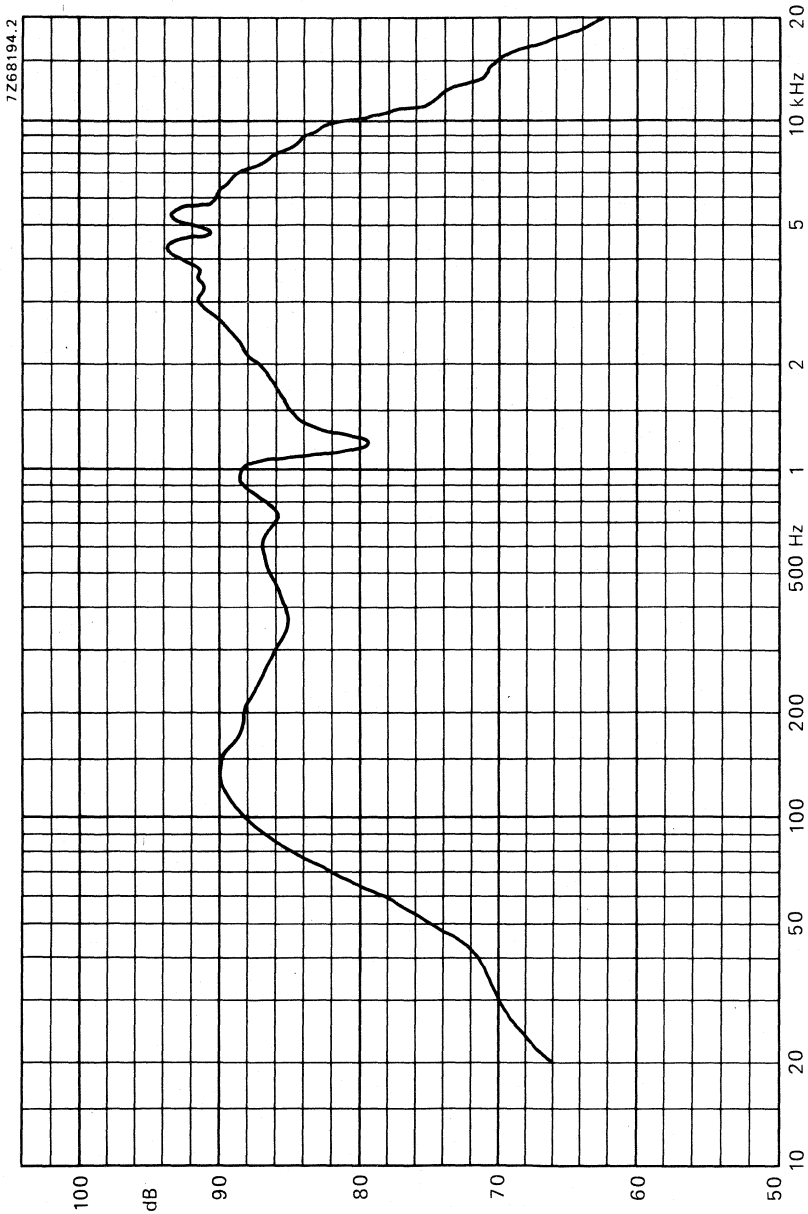

Fig. 2



DEVELOPMENT SAMPLE DATA

This information is derived from development samples made available for evaluation. It does not necessarily imply that the device will go into regular production.

AD7081/M4

7 INCH MEDIUM POWER LOUDSPEAKER

APPLICATION

For high-fidelity sound reproduction in video and audio applications.

TECHNICAL DATA

Rated impedance	4 Ω
Voice coil resistance	3,4 Ω
Rated frequency range	60 to 20 000 Hz
Resonance frequency	95 Hz
Power handling capacity, measured without filter	10 W
Maximum power on loudspeaker	17 W
Operating power	0,6 W
Sweep voltage, frequency range: 55 to 20 000 Hz	4,5 V
Energy in air gap	53 mJ
Flux density	0,98 T
Air-gap height	3 mm
Voice coil height	4,5 mm
Core diameter	18 mm
Magnet material	
diameter	53 mm
mass	0,1 kg
Mass of loudspeaker	0,29 kg

The loudspeaker has a dual paper cone and a treated-rim. Two tinned 2,8 mm (0,11 inch) tag connectors ← permit connection to the speaker by plugging or soldering.



Dimensions in mm

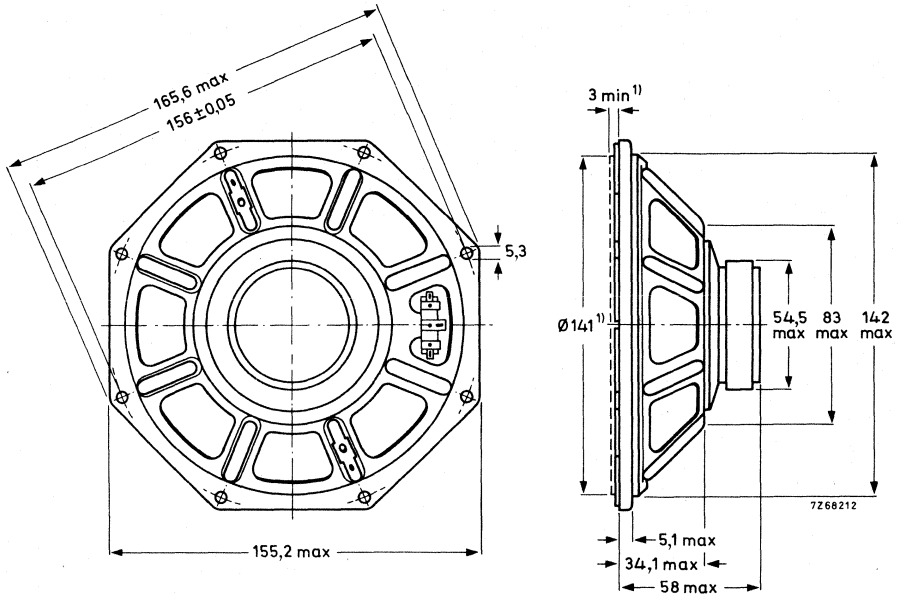

Fig. 1.

(1) Baffle hole and clearance depth required for cone movement at the specified power handling capacity.

One tag is indicated by a red mark for in-phase connection.

AVAILABLE VERSION

AD7081/M4, catalogue number 2422 257 37826

{ this number applies to bulk packed loudspeakers, minimum packing quantity 32 per unit.

FREQUENCY RESPONSE CURVES (See Fig. 2)

Measured in anechoic room at the operating power. Loudspeaker mounted on IEC baffle acc. to IEC 268 - 5 par. 4-4.

Curve a: Sound pressure.

Curves d2 and d3: 2nd and 3rd harmonic distortion.

DEVELOPMENT SAMPLE DATA

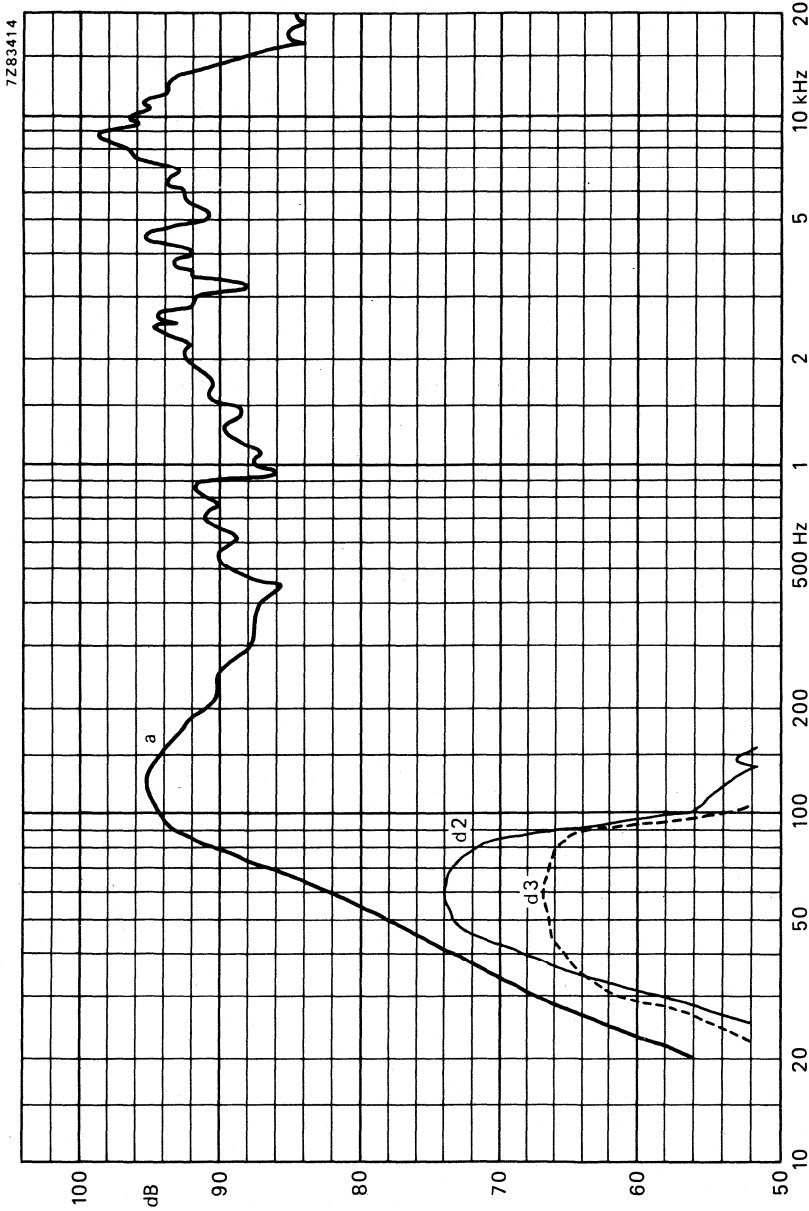

Fig. 2.



7 INCH MEDIUM POWER LOUDSPEAKER

APPLICATION

For video and audio equipment.

TECHNICAL DATA

	version	
	X4	X8
Rated impedance	4	8 Ω
Voice coil resistance	3,4	7,1 Ω
Rated frequency range	75 to 13 000 Hz	
Resonance frequency	115	Hz
Power handling capacity, measured without filter loudspeaker unmounted	4	W
Operating power for 90 dB sound level	0,85	0,7 W
Sweep voltage	2,8	4 V
Energy in air gap	39	mJ
Flux density	0,8	T
Air-gap height	3	mm
Voice coil height	4,5	3,9 mm
Core diameter	18	mm
Magnet material	steel alloy	
diameter	18	mm
mass	0,027	kg
Mass of loudspeaker	0,29	kg



The loudspeaker has a paper cone and surround, and foam segments.

Connection to the loudspeaker by means of 2,8 mm (0,11 inch) tag connectors or by soldering.

Dimensions in mm

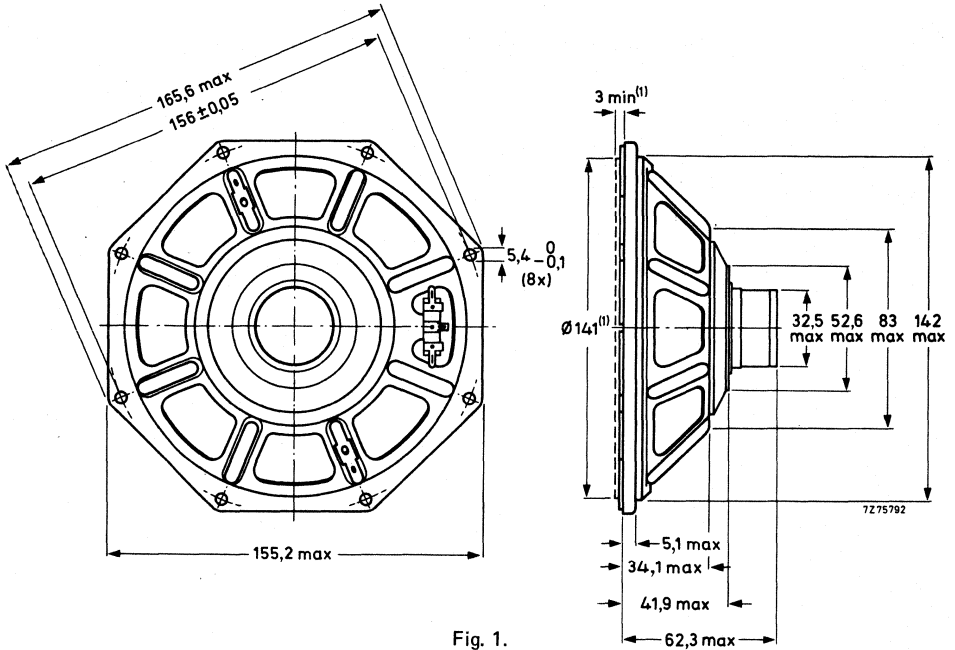

Fig. 1.

(1) Baffle hole and clearance depth required for cone movement at the specified power handling capacity. One tag is indicated by a red mark for in-phase connection.

→ AVAILABLE VERSIONS

AD7090/X4, catalogue number 2422 256 37121
 AD7090/X8, catalogue number 2422 256 37122

these numbers apply to bulk packed loudspeakers, minimum packing quantity 28 per unit.

FREQUENCY RESPONSE CURVES (see Fig. 2)

Measured in anechoic room at the operating power. Loudspeaker mounted on IEC baffle.

Curve a: Sound pressure.

Curves d2 and d3: 2nd and 3rd harmonic distortion.

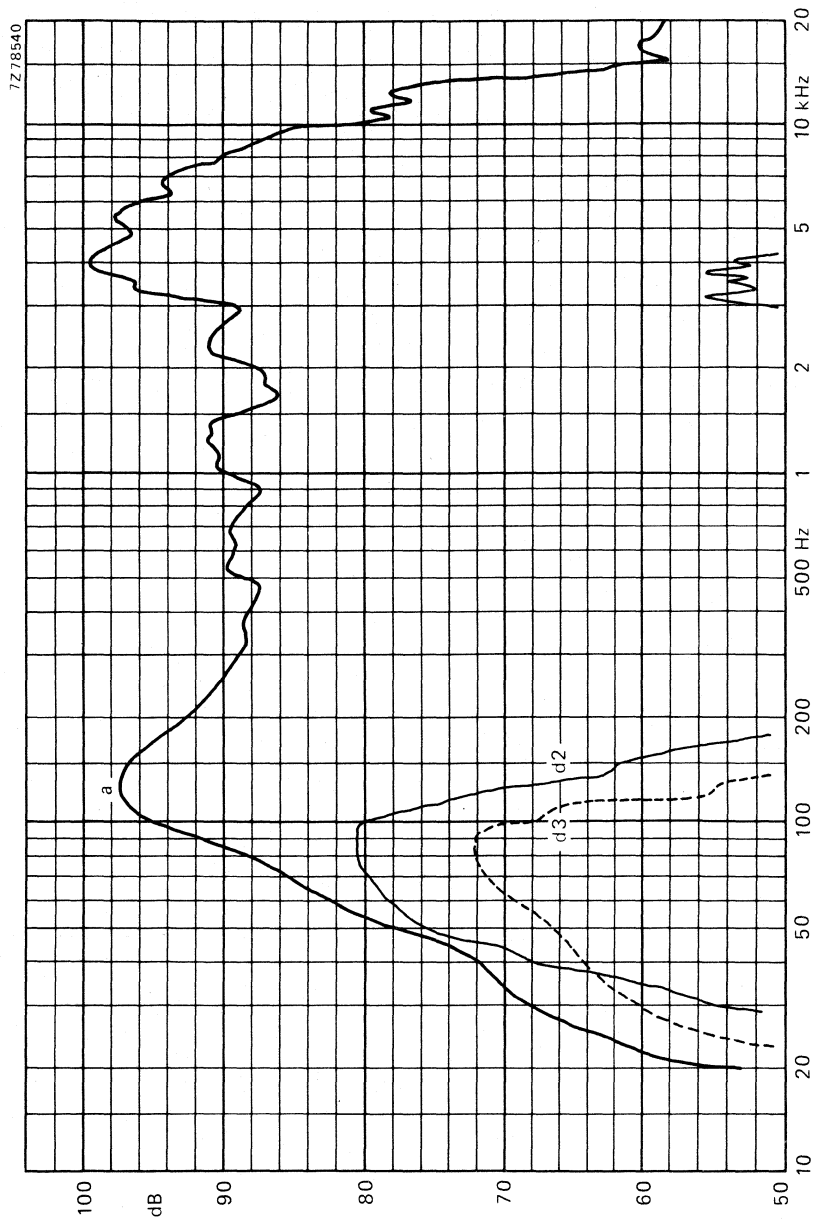

Fig. 2.



8 inch OCTAGONAL MEDIUM POWER LOUDSPEAKERS

APPLICATION

A full range loudspeaker for domestic radios, public address systems, and ceiling sets. This loudspeaker has an extended frequency response up to 20 kHz due to its dual-cone construction.

TECHNICAL DATA

	version	
	M4	M8
Rated impedance	4	8 Ω
Voice coil resistance	3, 4	7, 1 Ω
Rated frequency range	50 to 14 000 Hz	
Resonance frequency	75	Hz
Power handling capacity, measured without filter, loudspeaker unmounted	8	W
Operating power (sound level 90 dB, 1 m)	1	W
Sweep voltage (40 to 20 000 Hz)	4	5, 5 V
Energy in air gap	50	53 mJ
Flux density	0, 95	0, 98 T
Air gap height	3	mm
Voice coil height	6	5, 3 mm
Core diameter	18	mm
Magnet material	ceramic	
diameter	53	mm
mass	0, 1	kg
Mass of loudspeaker	0, 37	kg

The loudspeaker has a paper dual cone and surround. Connection to the loudspeaker by means of 2, 8 mm (0, 11 inch) tag connectors or by soldering.

Dimensions in mm

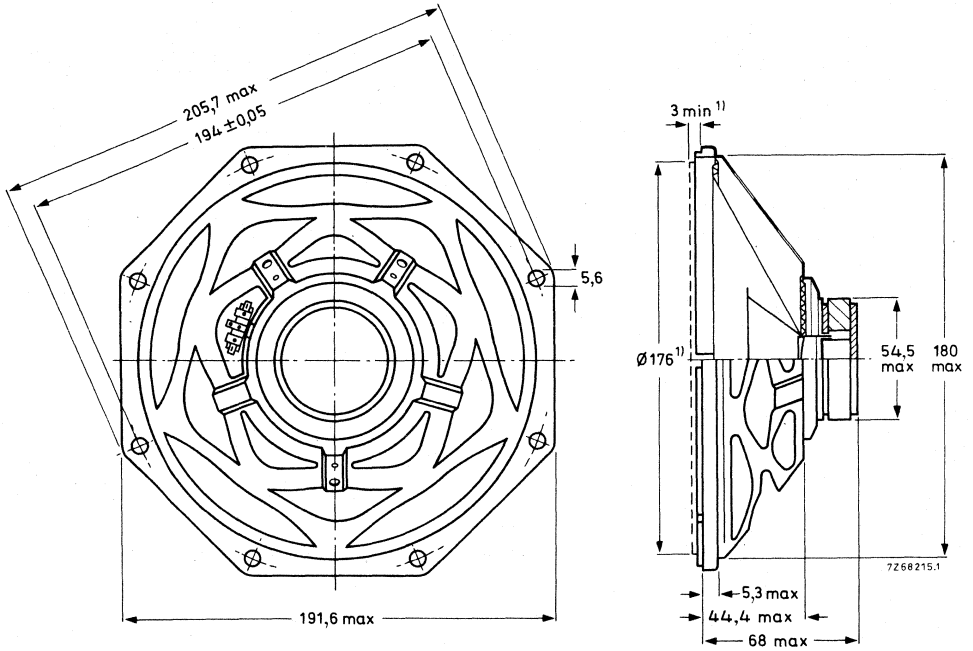

Fig. 1.

(1) Baffle hole and clearance depth required for cone movement at the specified power handling capacity. One tag is indicated by a red mark for in-phase connection.

→ AVAILABLE VERSIONS

AD8081/M4, catalogue number 2422 257 38231
 AD8081/M8, catalogue number 2422 257 38232

} these numbers apply to bulk packed loudspeakers, minimum packing quantity 28 per unit.

FREQUENCY RESPONSE CURVES (see Fig. 2)

Curve b: Sound pressure measured in anechoic room, loudspeaker mounted on baffle according to IEC 268-5, par. 4.4.

Curve c: 2nd and 3rd harmonic distortion, measured at the operating power of 1 W in anechoic room. Loudspeaker front mounted on IEC baffle.

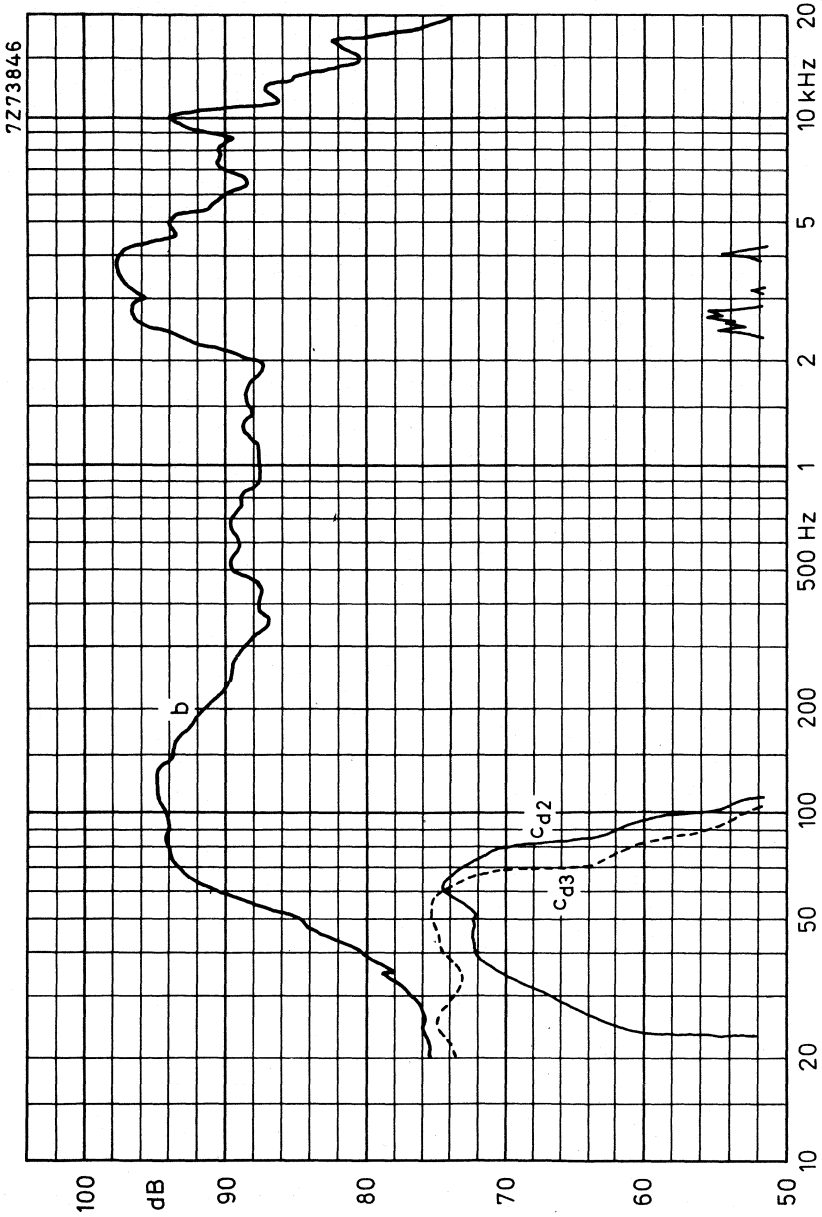

Fig. 2



8 inch OCTAGONAL MEDIUM POWER LOUDSPEAKER

APPLICATION

For domestic radios, public address systems, and ceiling sets. High sensitivity at 4000 Hz.

TECHNICAL DATA

	version		
	X4	X8	
Rated impedance	4	8	Ω
Voice coil resistance	3,4	7,1	Ω
Rated frequency range	70 to 11 000		Hz
Resonance frequency	95		Hz
Power handling capacity, measured without filter, loudspeaker unmounted	8		W
Operating power (sound level 90 dB, 1 m)	0,7		W
Sweep voltage (50 to 20 000 Hz)	4	5,6	V
Energy in air gap	53		mJ
Flux density	0,98		T
Air gap height	3		mm
Voice coil height	6	5,3	mm
Core diameter	18		mm
Magnet material	ceramic		
diameter	53		mm
mass	0,1		kg
Mass of loudspeaker	0,37		kg

The loudspeaker has a paper cone and surround. Connection to the loudspeaker by means of 2,8 mm (0,11 inch) tag connectors or by soldering.

Dimensions in mm

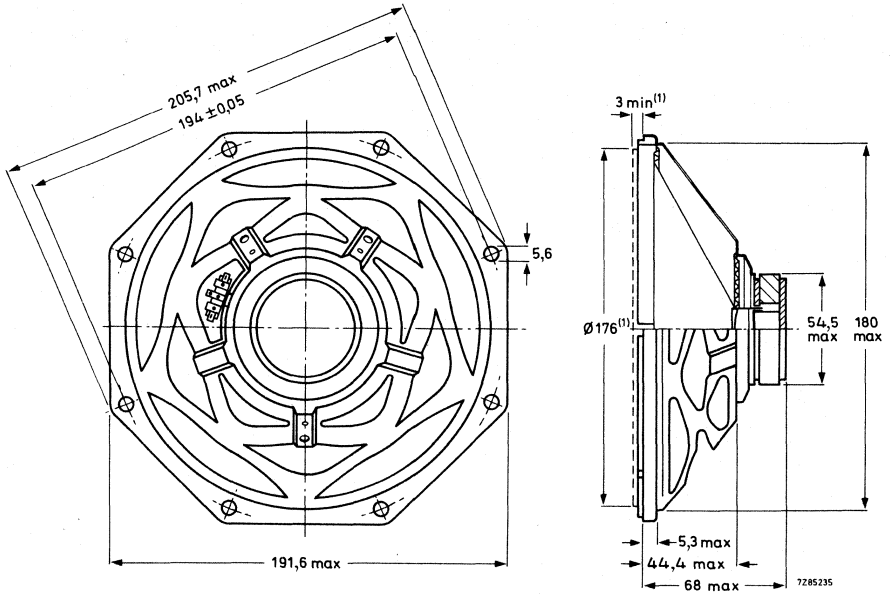

Fig. 1.

(1) Baffle hole and clearance depth required for cone movement at the specified power handling capacity. One tag is indicated by a red mark for in-phase connection.

→ AVAILABLE VERSIONS

AD8081/X4, catalogue number 2422 257 38233
 AD8081/X8, catalogue number 2422 257 38234

} these numbers apply to bulk packed loudspeakers, minimum packing quantity 28 per unit.

FREQUENCY RESPONSE CURVES (see Fig. 2)

Curve b: Sound pressure measured in anechoic room, loudspeaker mounted on baffle according to IEC 268-5, par. 4.4.

Curve c: 2nd and 3rd harmonic distortion, measured at the operating power of 0,7 W in anechoic room. Loudspeaker front mounted on IEC baffle.

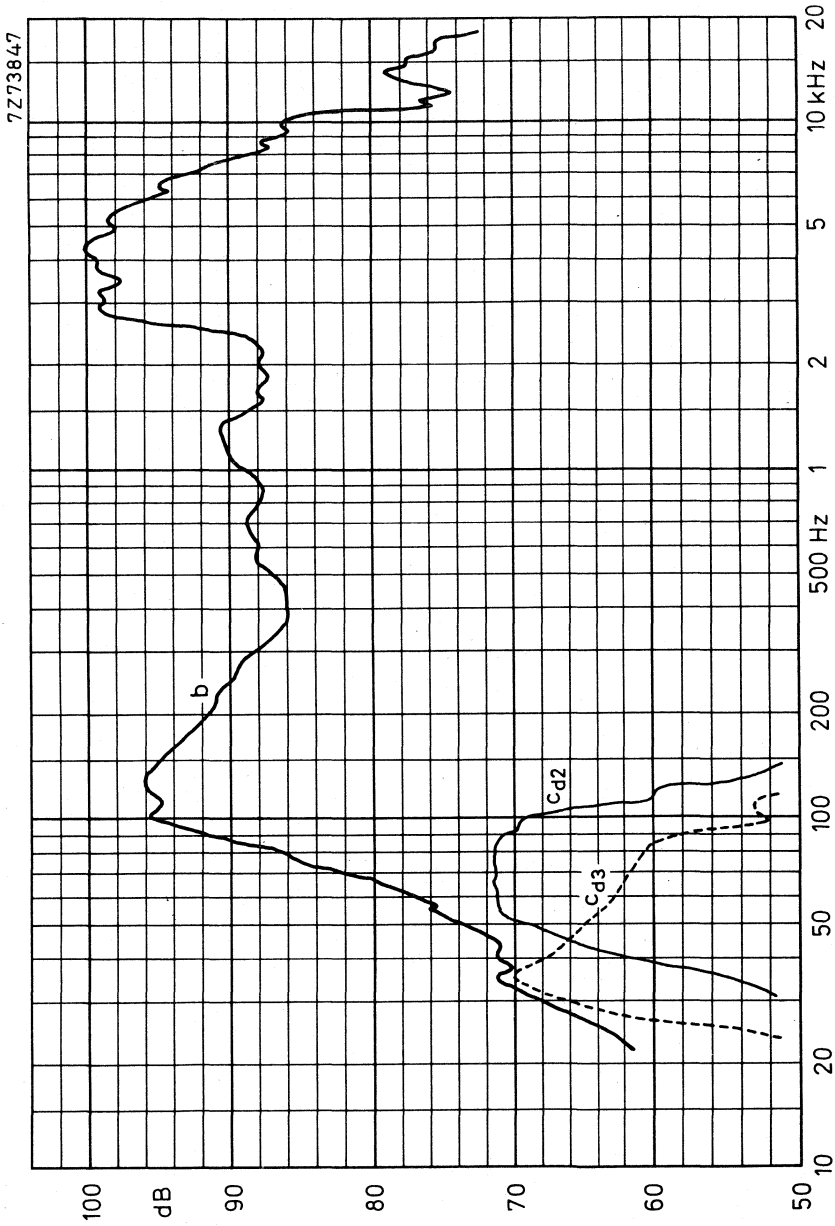

Fig. 2



8 INCH MEDIUM POWER LOUDSPEAKER

APPLICATION

A full range loudspeaker for domestic radios, public address systems, and ceiling sets. This loudspeaker has an extended frequency response up to 15 000 Hz due to its dual-cone construction.

TECHNICAL DATA

	version	
	M4	M8
Rated impedance	4	8 Ω
Voice coil resistance	3,2	7 Ω
Rated frequency range	50 to 15 000 Hz	
Resonance frequency	95	Hz
Power handling capacity, measured without filter, loudspeaker unmounted	13	W
Maximum power on loudspeaker	27	30 W
Operating power (sound level 90 dB, 1 m)	0,7	0,66 W
Sweep voltage (50 to 20 000 Hz)	5,1	7,2 V
Energy in air gap	50	53 mJ
Flux density	0,98	T
Air-gap height	3	mm
Voice coil height	3,5	4,5 mm
Core diameter	18	mm
Magnet material	ceramic	
diameter	53	mm
mass	0,1	kg
Mass of loudspeaker	0,37	kg

The loudspeaker has a paper dual cone, impregnated paper surround and foam segments. Connection to the loudspeaker by means of 2,8 mm (0,11 inch) tag connectors or by soldering.

Dimensions in mm

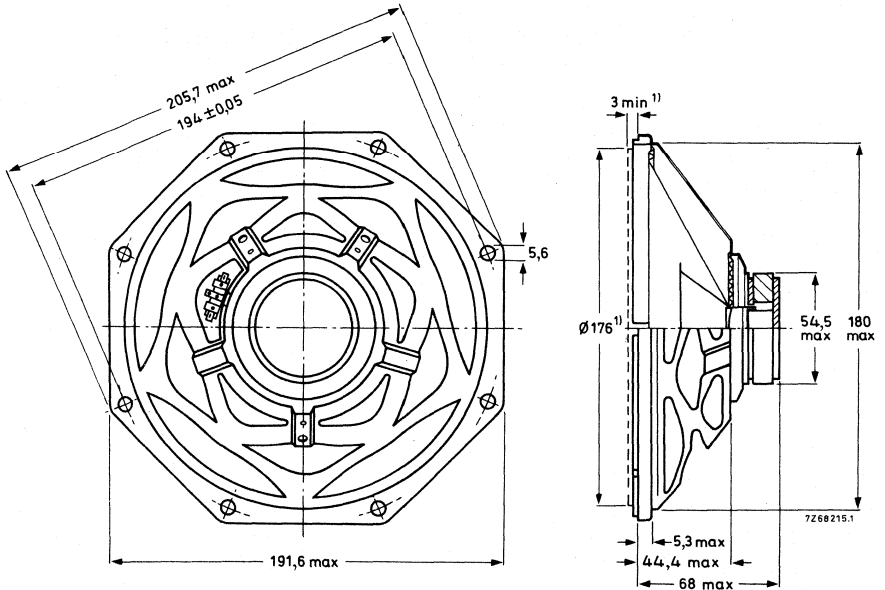

Fig. 1.

(1) Baffle hole and clearance depth required for cone movement at the specified power handling capacity. One tag is indicated by a red mark for in-phase connection.

→ AVAILABLE VERSIONS

AD8082/M4, catalogue number 2422 257 38235
 AD8082/M8, catalogue number 2422 257 38236

} these numbers apply to bulk packed loudspeakers, minimum packing quantity 28 per unit.

FREQUENCY RESPONSE CURVES (see Fig. 2)

Measured in anechoic room, loudspeaker mounted on IEC baffle.

Curve a: Sound pressure.

Curves d2 and d3: 2nd and 3rd harmonic distortion, measured at the operating power.

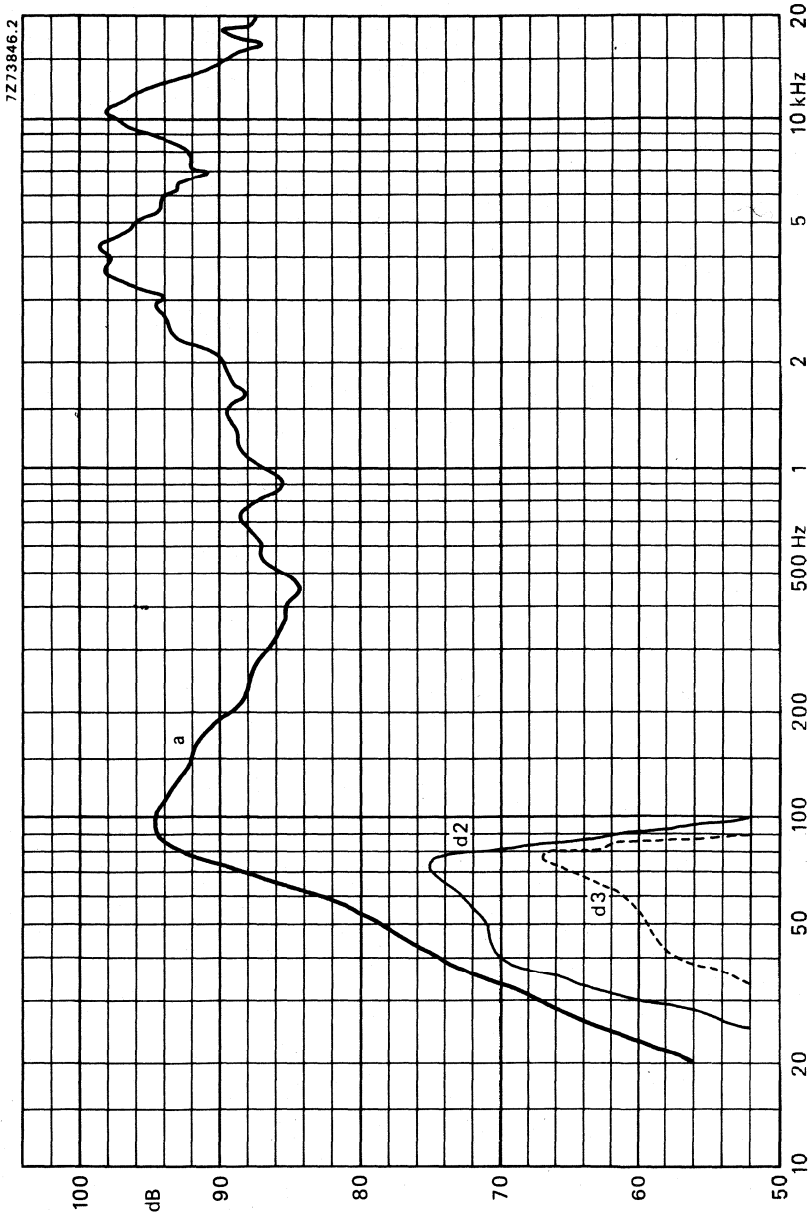

Fig. 2.



DEVELOPMENT SAMPLE DATA

This information is derived from development samples made available for evaluation. It does not necessarily imply that the device will go into regular production.

AD8082/X8

8 INCH MEDIUM POWER LOUDSPEAKER

APPLICATION

A full range loudspeaker for domestic radios, public address systems, and ceiling sets. High sensitivity at 4000 Hz.

TECHNICAL DATA

Rated impedance	8 Ω
Voice coil resistance	7 Ω
Rated frequency range	50 to 9000 Hz
Resonance frequency	95 Hz
Power handling capacity, measured without filter, loudspeaker unmounted	13 W
Maximum power	30 W
Operating power	1,1 W
Sweep voltage, frequency range: 50 to 20 000 Hz	7,2 V
Maximum excursion voltage at 20 Hz	to be established
Energy in air gap	53 mJ
Flux density	0,98 T
Air-gap height	3 mm
Voice coil height	4,5 mm
Core diameter	18 mm
Magnet material	ceramic
diameter	53 mm
mass	0,1 kg
Mass of loudspeaker	0,36 kg

The loudspeaker has a paper cone, a treated paper surround, a foam plastic gasket on the flange, and an aluminium coil former (resulting in a high power handling capacity). Connection to the loudspeaker by means of 2,8 mm (0,11 inch) tag connectors or by soldering.



Dimensions in mm

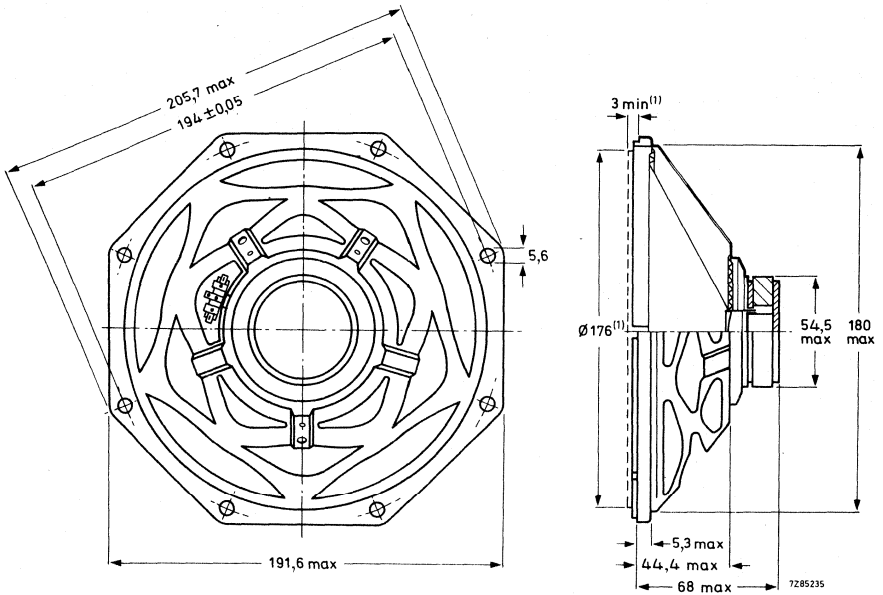

Fig. 1.

(1) Baffle hole and clearance depth required for cone movement at the specified power handling capacity.

One tag is indicated by a red mark for in-phase connection.

AVAILABLE VERSION

AD8082/X8, catalogue number 2422 257 38238

this number applies to bulk packed loudspeakers, minimum packing quantity 28 per unit.

FREQUENCY RESPONSE CURVES (See Fig. 2)

Measured in anechoic room at the operating power. Loudspeaker mounted on IEC baffle according to IEC 268-5 par. 4-4.

Curve a: Sound pressure.

Curves d2 and d3: 2nd and 3rd harmonic distortion.

DEVELOPMENT JAMES LL BATA

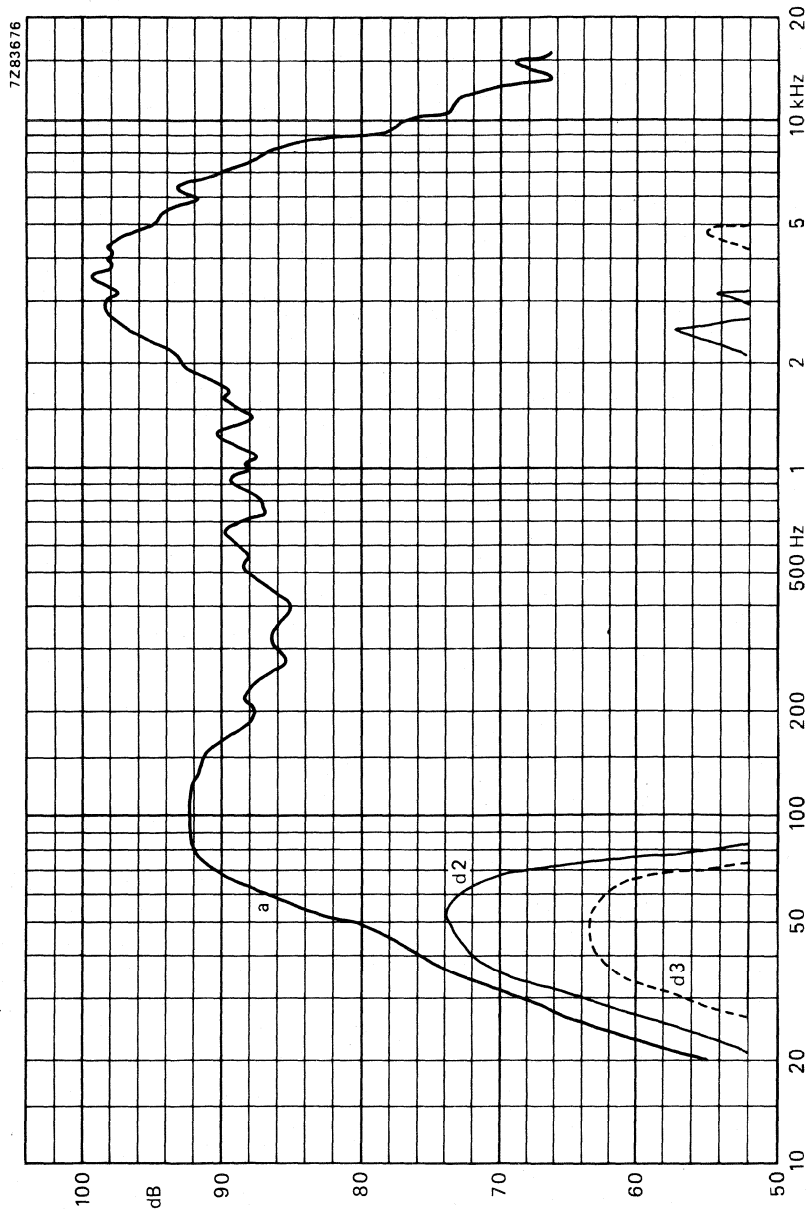

Fig. 2.



HIGH POWER FULL-RANGE LOUDSPEAKERS



721010-26-08

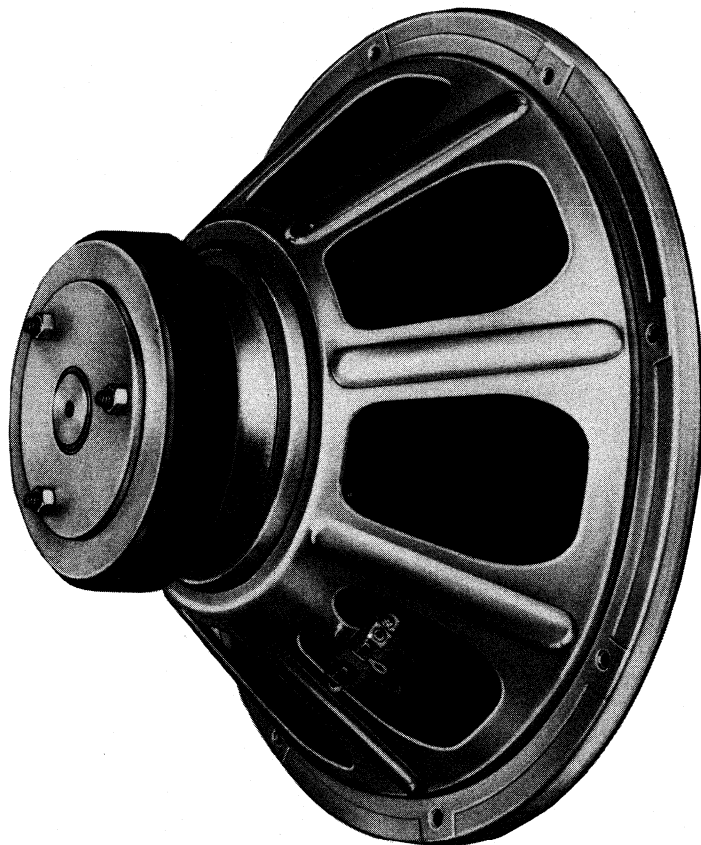

Type AD12100/M4



DEVELOPMENT SAMPLE DATA

This information is derived from development samples made available for evaluation. It does not necessarily imply that the device will go into regular production.

AD40400/M4

4 INCH HIGH POWER FULL RANGE LOUDSPEAKER

APPLICATION

For high-fidelity sound reproduction in car radios.

TECHNICAL DATA

Rated impedance	4 Ω
Voice coil resistance	3,2 Ω
Rated frequency range	50 to 20 000 Hz
Resonance frequency	110 Hz
Power handling capacity, measured without filter	15 W
Maximum power on loudspeaker	25 W
Operating power	4 W
Sweep voltage, frequency range: 60 to 20 000 Hz	5,5 V
Energy in air gap	78 mJ
Flux density	1,15 T
Air-gap height	3 mm
Voice coil height	4,2 mm
Core diameter	18 mm
Magnet material	ceramic
diameter	60 mm
mass	0,154 kg
Mass of loudspeaker	0,36 kg

The loudspeaker has a dual paper cone, a textile surround, a foam plastic gasket on the flange, and an aluminium coil former (resulting in a high power handling capacity).



AD40400/M4

Dimensions in mm

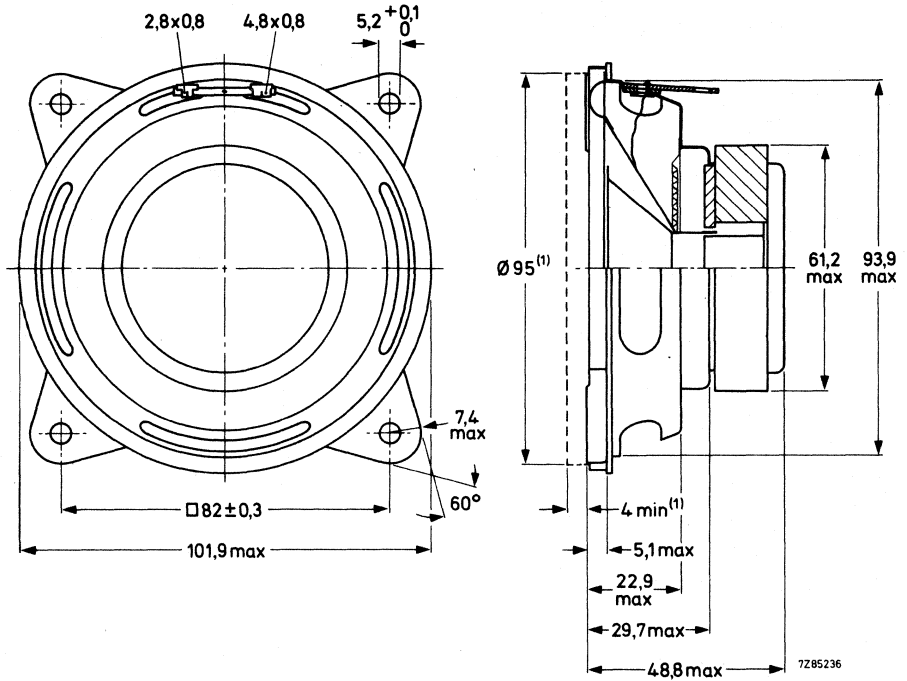

Fig. 1.

(1) Baffle hole and clearance depth required for cone movement at the specified power handling capacity.

The 4,8 mm (0,19 inch) tag should be used for in-phase connection.

AVAILABLE VERSION

AD40400/M4, catalogue number 2422 257 34625

this number applies to bulk packed loudspeakers, minimum packing quantity 27 per unit.

FREQUENCY RESPONSE CURVE (See Fig. 2)

Measured in anechoic room at the operating power. Loudspeaker mounted on IEC baffle according to IEC 268-5 par. 4.4.

Curve a: Sound pressure.

Curves d2 and d3: 2nd and 3rd harmonic distortion.

DEVELOPMENT NUMBER 7283667

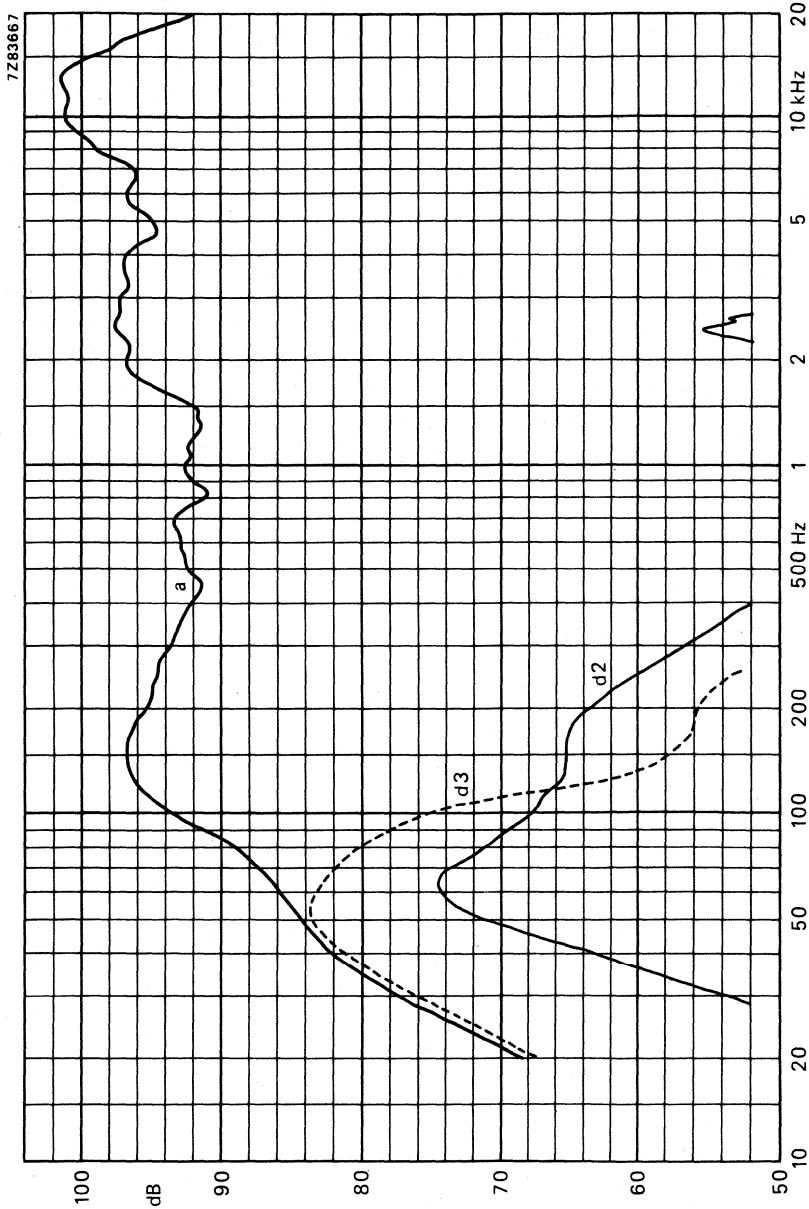

Fig. 2.



DEVELOPMENT SAMPLE DATA

This information is derived from development samples made available for evaluation. It does not necessarily imply that the device will go into regular production.

AD4060/M.

4 INCH HIGH POWER FULL RANGE LOUDSPEAKER

APPLICATION

For car radios.

TECHNICAL DATA

	version	
	M4	M8
Rated impedance	4	8 Ω
Voice coil resistance	3,2	7 Ω
Rated frequency range	75-20 000	Hz
Resonance frequency	100	Hz
Power handling capacity, mounted on IEC baffle	20	W
Operating power	6,2	W
Sweep voltage, frequency range: 50 to 20 000 Hz	6,3	8,9 V
Energy in air gap	127	mJ
Flux density	0,87	T
Air-gap height	5	mm
Voice coil height	6	6,6 mm
Core diameter	25	mm
Magnet material	ceramic	
diameter	72	mm
mass	0,26	kg
Mass of loudspeaker	0,62	kg

The loudspeaker has a paper cone, a textile surround and a hard paper gasket. Connection to the loudspeaker by means of a 2,8 mm (0,11 inch) and a 4,8 mm (0,19 inch) tag connector or by soldering.

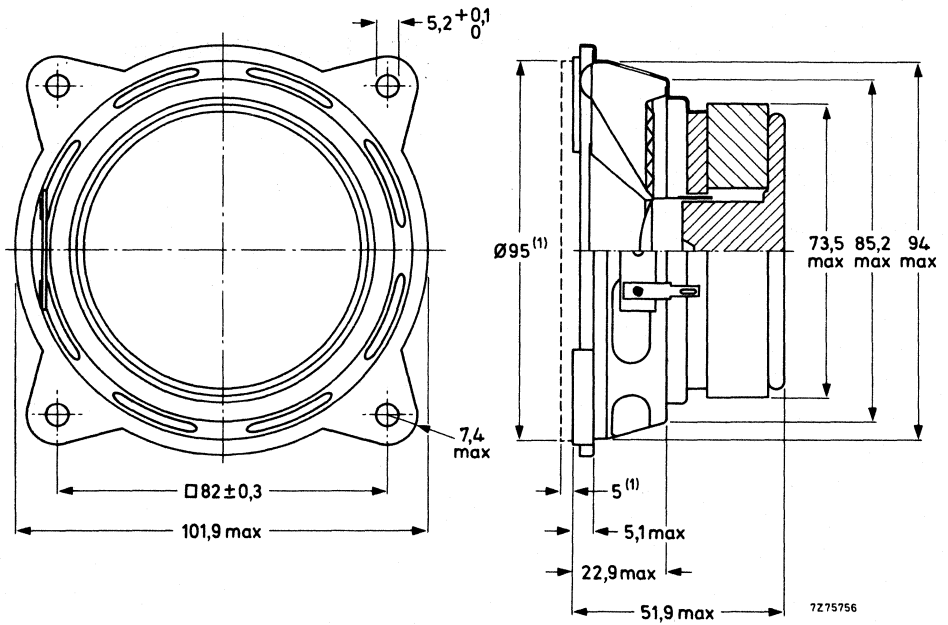

Fig. 1.

(1) Baffle hole and clearance depth required for cone movement at the specified power handling capacity.

The largest of the two connection tags should have + polarity.

→ AVAILABLE VERSIONS

AD4060/M4, catalogue number 2422 257 34639

AD4060/M8, catalogue number 2422 257 34637

} these numbers apply to bulk packed loudspeakers, minimum packing quantity 32 per unit.

FREQUENCY RESPONSE CURVES (see Fig. 2)

Measured in anechoic room, loudspeaker mounted on IEC baffle.

Curve a: Sound pressure.

Curves d2 and d3: 2nd and 3rd harmonic distortion, measured at the operating power of 6,2 W.

DEVELOPMENT SAMPLE DATA

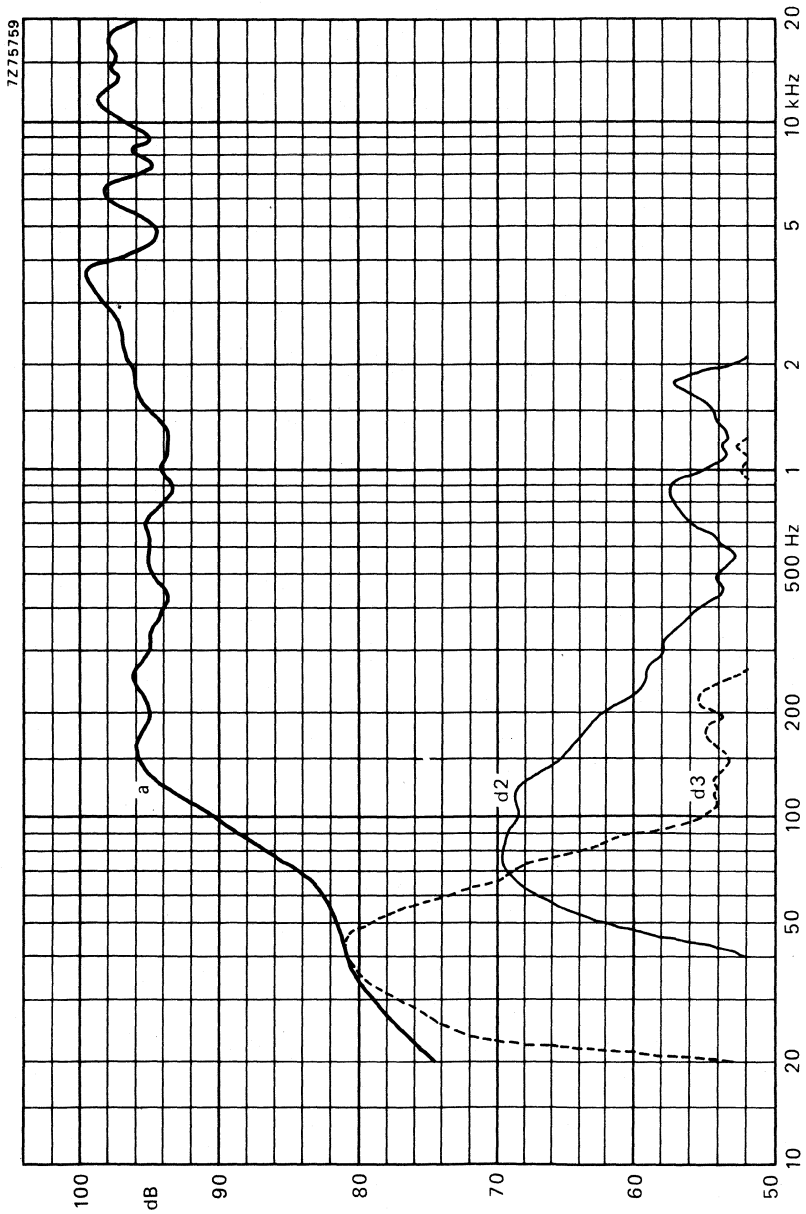

Fig. 2.



DEVELOPMENT SAMPLE DATA

This information is derived from development samples made available for evaluation. It does not necessarily imply that the device will go into regular production.

AD40900/M.

4 INCH HIGH POWER FULL RANGE LOUDSPEAKERS

APPLICATION

For high-fidelity sound reproduction in video and audio applications.

TECHNICAL DATA

	version			
	M4	M8	M15	M25
Rated impedance	4	8	15	25 Ω
Voice coil resistance	3,4	7,1	13,5	22,7 Ω
Rated frequency range	60 to 20 000			Hz
Resonance frequency	90			Hz
Power handling capacity, measured without filter	8	8	8	8 W
Operating power	0,9	1,62	1,54	1,44 W
Sweep voltage, frequency range: 35 to 20 000 Hz	4	5,7	7,7	10 V
Energy in air gap	65			mJ
Flux density	1,045			T
Air-gap height	3			mm
Voice coil height	4,5	3,9	3,2	4 mm
Core diameter	18			mm
Magnet material	ceramic			
diameter	45			mm
mass	0,102			kg
Mass of loudspeaker	0,350			kg

The loudspeaker has a dual paper cone and a foam rubber surround. Two tinned 2,8 mm (0,11 inch) tag connectors permit connection to the loudspeaker by plugging or soldering.

AD40900/M.

Dimensions in mm

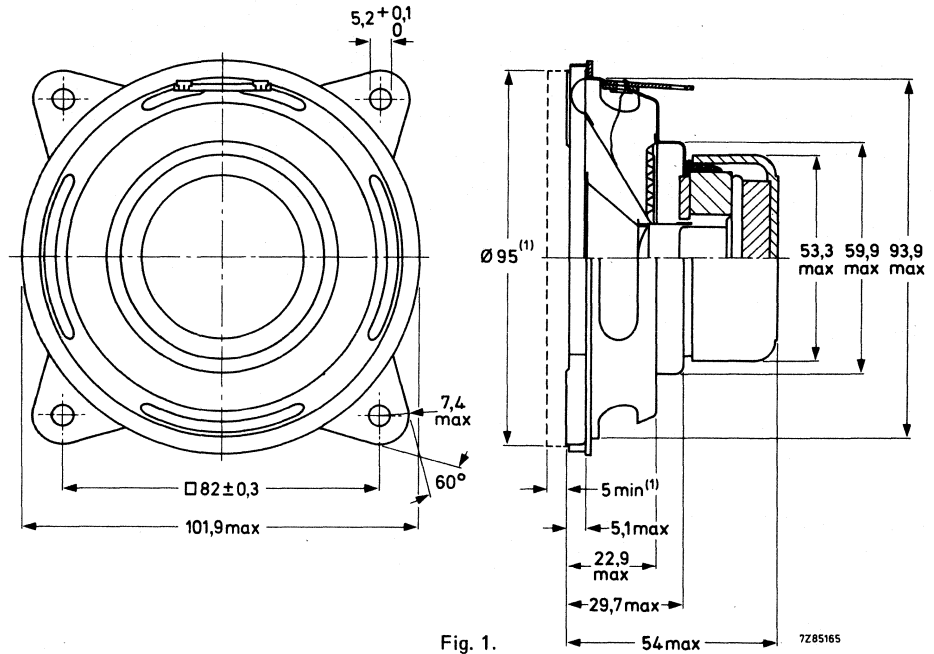

Fig. 1.

(1) Baffle hole and clearance depth required for cone movement at the specified power handling capacity.

One tag is indicated by a red mark for in-phase connection.

→ AVAILABLE VERSIONS

AD40900/M4, catalogue number 2422 257 34831
 AD40900/M8, catalogue number 2422 257 34832
 AD40900/M15, catalogue number 2422 257 34833
 AD40900/M25, catalogue number 2422 257 34834

these numbers apply to bulk packed loudspeakers, minimum packing quantity 27 per unit.

FREQUENCY RESPONSE CURVE (See Fig. 2)

Measured in anechoic room at the operating power. Loudspeaker mounted on IEC baffle acc. to IEC 268-5 par. 4-4.

Curve a: Sound pressure.

Curves d2 and d3: 2nd and 3rd harmonic distortion.

DEVELOPMENT SAMPLE DATA

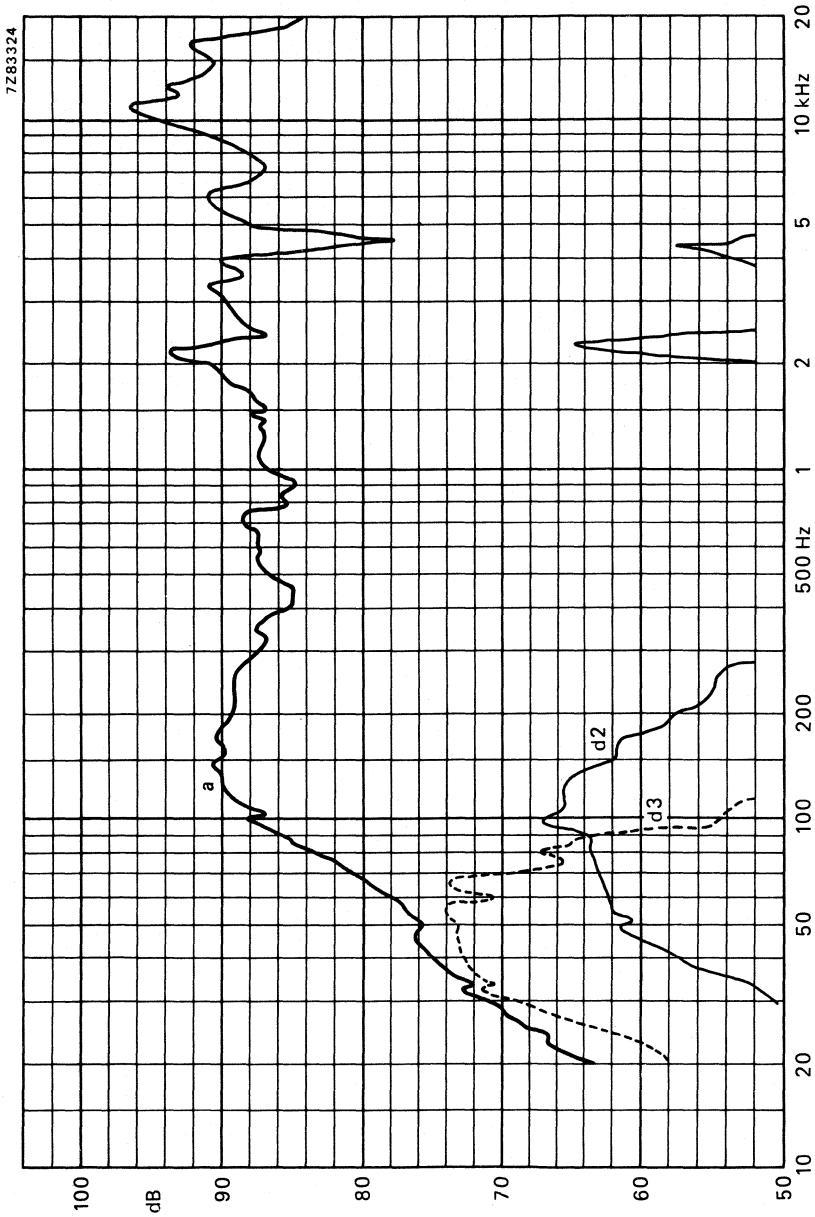

Fig. 2.



5 INCH HIGH POWER FULL RANGE LOUDSPEAKER

APPLICATION

A full range loudspeaker for small sealed enclosures of maximum 7 litres and also suitable for use in bookshelves enclosures.

Extended frequency response 75 Hz – 20 kHz in 7 litres enclosures.

TECHNICAL DATA

	version	
	M4	M8
Rated impedance	4	8 Ω
Voice coil resistance	3,2	7 Ω
Rated frequency range	75 to 20 000 Hz	
Resonance frequency	85	Hz
Power handling capacity measured without filter, loudspeaker unmounted	10	W
mounted in 7 l sealed enclosure	15	W
Operating power	2	3 W
Sweep voltage	3,2	4,5 V
Energy in air gap	127	mJ
Flux density	0,87	T
Air-gap height	5	mm
Voice coil height	6	6,6 mm
Core diameter	25	mm
Magnet material	ceramic	
diameter	27	mm
mass	0,26	kg
Mass of loudspeaker	0,6	kg

The loudspeaker has a paper cone, a textile surround and a foam plastic gasket on the flange.
Connection to the loudspeaker by means of 2,8 mm (0,11 inch) tag connectors or by soldering.

Dimensions in mm

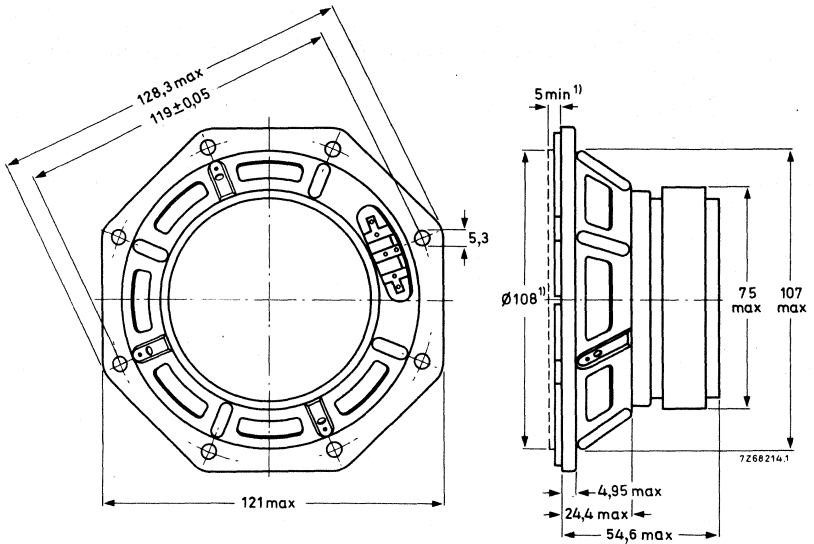

Fig. 1.

(1) Baffle hole and clearance depth required for cone movement at the specified power handling capacity.

One tag is indicated by a red mark for in-phase connection.

→ AVAILABLE VERSIONS

AD5061/M4, catalogue number 2422 257 35531
 AD5061/M8, catalogue number 2422 257 35532

} these numbers apply to bulk packed loudspeakers, minimum packing quantity 32 per unit.

FREQUENCY RESPONSE CURVE (See Fig. 2)

Measured in anechoic room at the operating power. Loudspeaker mounted on IEC baffle.

Curve a: Sound pressure.

Curves d2 and d3: 2nd and 3rd harmonic distortion.

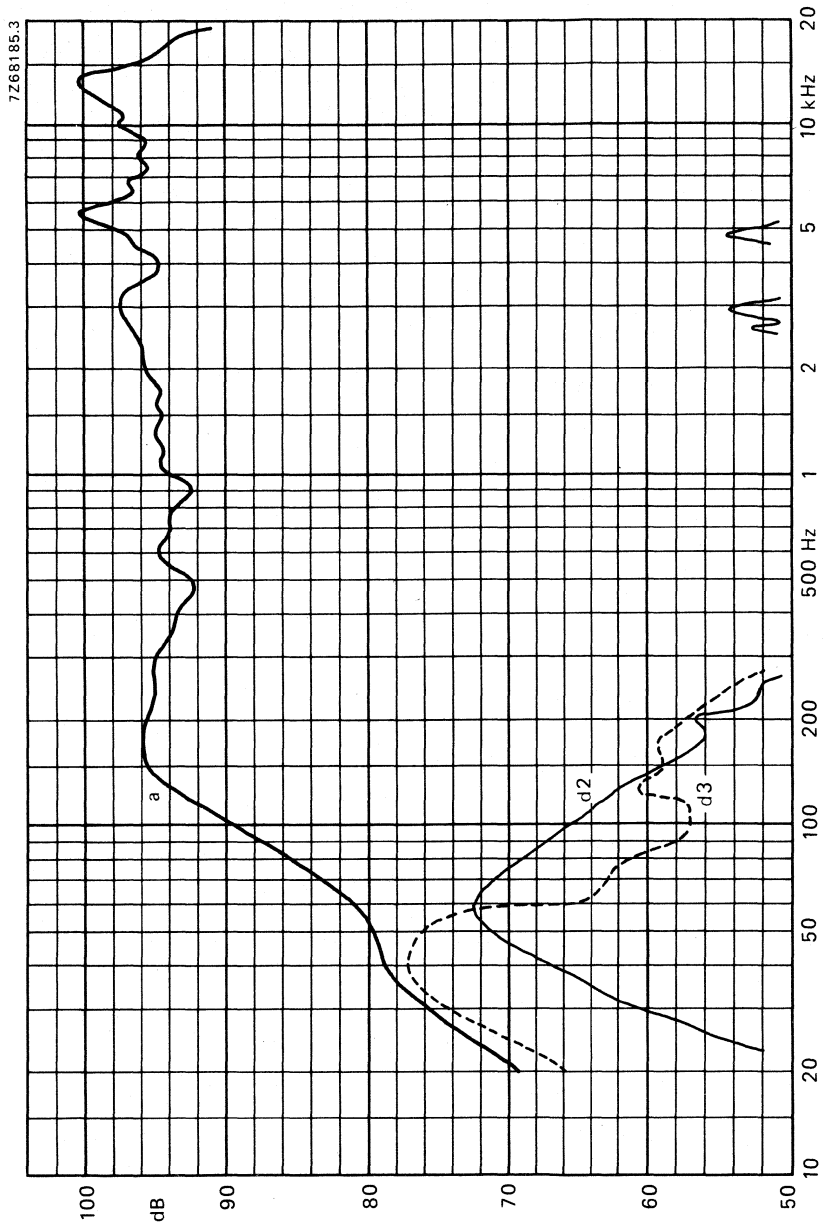

Fig. 2.



DEVELOPMENT SAMPLE DATA

This information is derived from development samples made available for evaluation. It does not necessarily imply that the device will go into regular production.

AD51600/P4

5¼ INCH HIGH POWER FULL RANGE LOUDSPEAKER

APPLICATION

For high-fidelity sound reproduction in car radio applications and open enclosures. The loudspeaker has a very low distortion.

TECHNICAL DATA

Rated impedance	4 Ω
Voice coil resistance	3,8 Ω
Rated frequency range	60 to 8000 Hz
Resonance frequency	78 Hz
Power handling capacity, measured without filter	20 W
Maximum power on loudspeaker	40 W
Operating power	6,25 W
Sweep voltage, frequency range: 42 to 20 000 Hz	6,2 V
Energy in air gap	135 mJ
Flux density	0,87 T
Air-gap height	5 mm
Voice coil height	10 mm
Core diameter	25 mm
Magnet material	ceramic
diameter	72 mm
mass	0,26 kg
Mass of loudspeaker	0,636 kg

The loudspeaker has a paper cone and a textile surround. Two tinned 2,8 mm (0,11 inch) tag connectors permit connection to the speaker by plugging or soldering.



Dimensions in mm

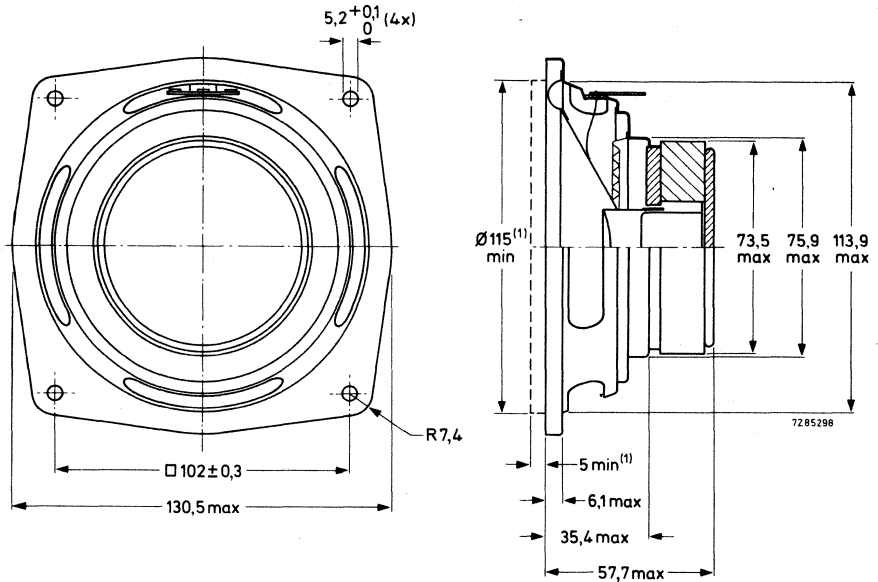

Fig. 1.

(1) Baffle hole and clearance depth required for cone movement at the specified power handling capacity.

One tag is indicated by a red mark for in-phase connection.

AVAILABLE VERSION

AD51600/P4, catalogue number 2422 257 35825

this number applies to bulk packed loudspeakers, minimum packing quantity 32 per unit.

FREQUENCY RESPONSE CURVE (See Fig. 2)

Measured in anechoic room at the operating power. Loudspeaker mounted on IEC baffle according to IEC 268-5 par. 4-4.

Curve a: Sound pressure.

Curves d2 and d3: 2nd and 3rd harmonic distortion.

DEVELOPMENT SAMPLE DATA

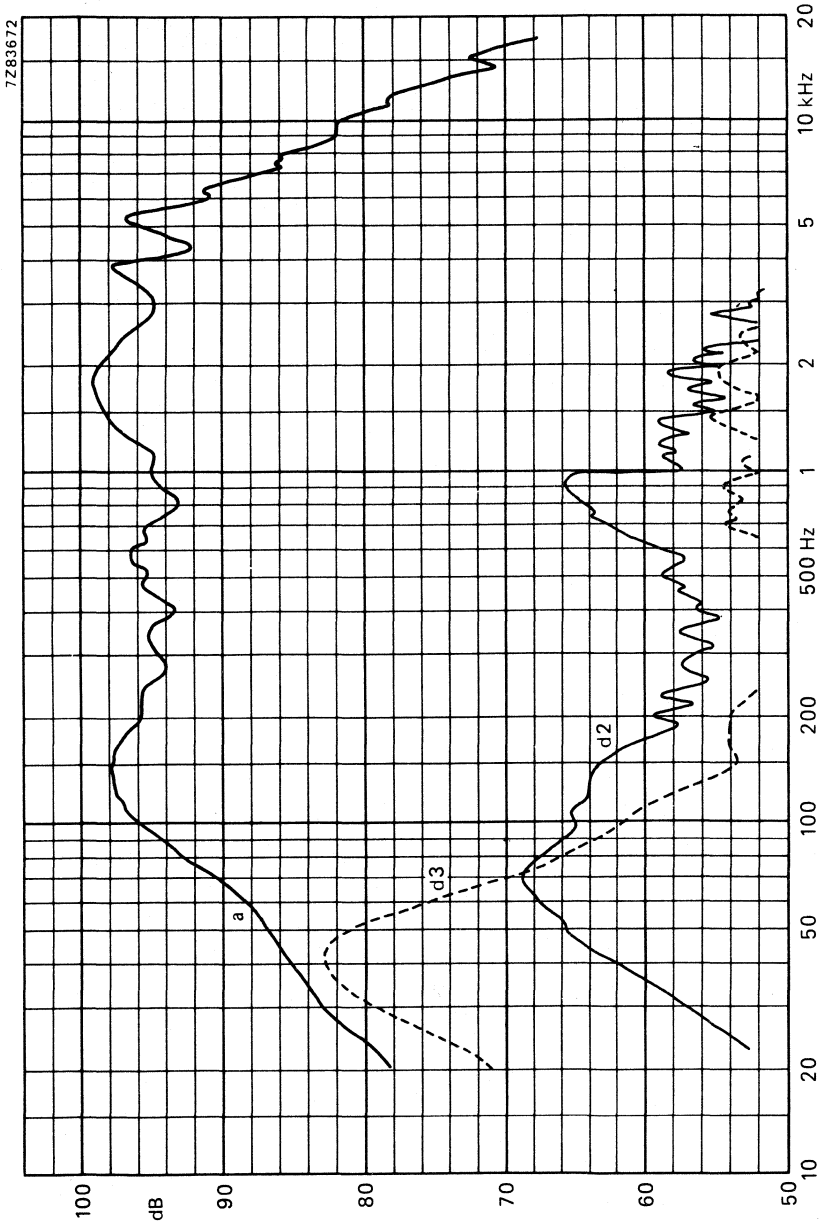

Fig. 2.



DEVELOPMENT SAMPLE DATA

This information is derived from development samples made available for evaluation. It does not necessarily imply that the device will go into regular production.

AD57900/M.

5 × 7 INCH MEDIUM POWER LOUDSPEAKER

APPLICATION

The loudspeaker can be used in black and white and colour television sets. The magnet has a screened and compensated ceramic system with a very low stray magnetic field. High sensitivity at 4000 Hz.

TECHNICAL DATA

	version	
	M4	M8
Rated impedance	4	8 Ω
Voice coil resistance	3,4	7,1 Ω
Rated frequency range	60 to 10 000	Hz
Resonance frequency	100	Hz
Power handling capacity, measured without filter, loudspeaker unmounted	10	W
Maximum power on loudspeaker	15	W
Operating power	0,75	0,7 W
Sweep voltage, frequency range: 55 to 20 000 Hz	4,5	6,3 V
Energy in air gap	65	mJ
Flux density	1,045	T
Stray magnetic field according to DIN 45578 par. 2.2.5, distance 70 mm	0,35	mT
Air-gap height	3	mm
Voice coil height	4,5	4,3 mm
Core diameter	18	mm
Magnet material	ceramic	
diameter	53	mm
mass	0,102	kg
Mass of loudspeaker	0,346	kg

The loudspeaker has a dual paper cone, a treated paper surround, and a foam plastic gasket on the flange. Connection to the loudspeaker by means of 2,8 mm (0,11 inch) tag connectors or by soldering.

Dimensions in mm

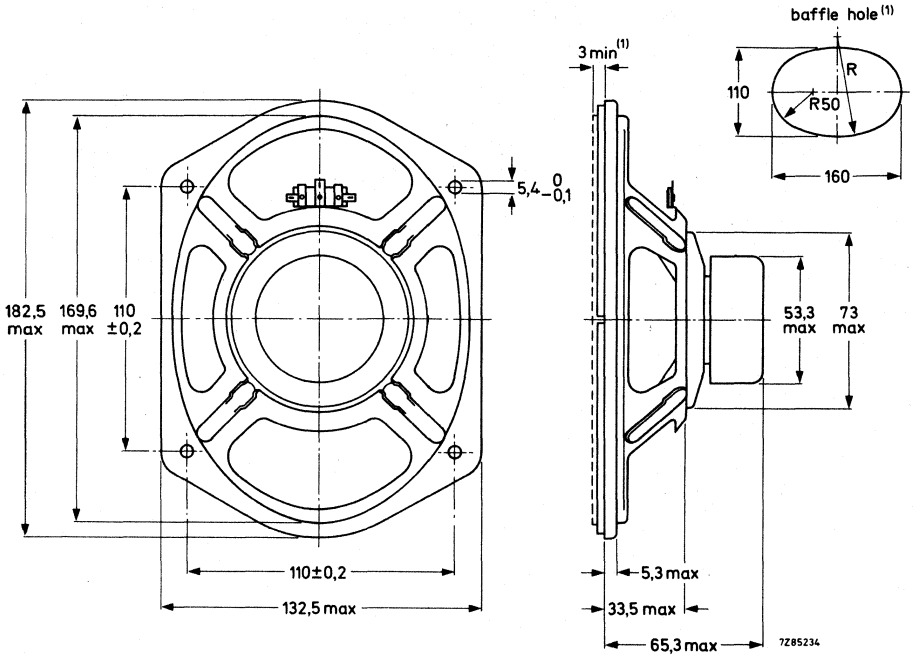

Fig. 1.

(1) Clearance depth required for cone movement at the specified power handling capacity. One tag is indicated by a red mark for in-phase connection.

AVAILABLE VERSIONS

AD57900/M4, catalogue number 2422 257 36225
 AD57900/M8, catalogue number 2422 257 36226

these numbers apply to bulk packed loudspeakers, minimum packing quantity 28 per unit.

FREQUENCY RESPONSE CURVE (See Fig. 2)

Measured in anechoic room at the operating power. Loudspeaker mounted on IEC baffle according to IEC 268-5 par. 4-4.

Curve a: Sound pressure.

Curves d2 and d3: 2nd and 3rd harmonic distortion.

DEVELOPMENT SAMPLE DATA

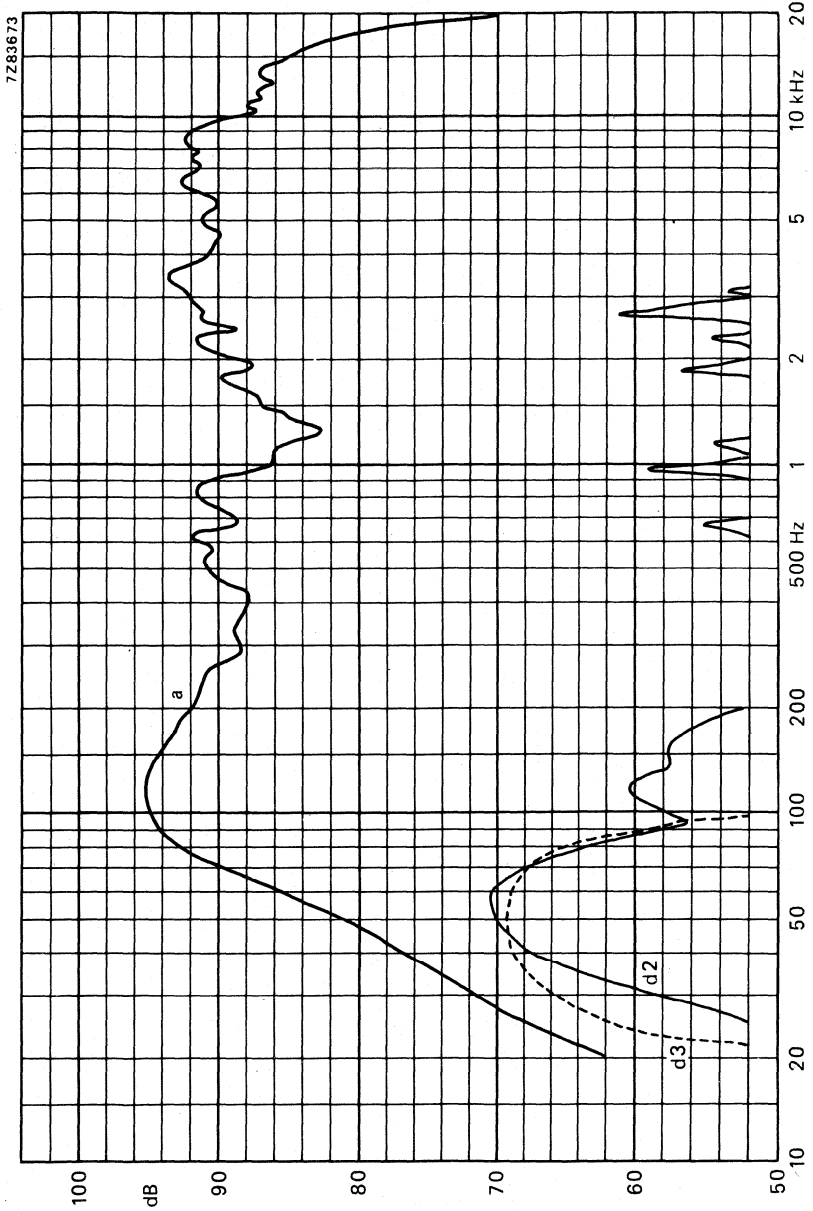

Fig. 2.



7 INCH HIGH POWER FULL RANGE LOUDSPEAKER

APPLICATION

For high fidelity reproduction in sealed acoustic enclosures. Maximum enclosure volume 7 litres. High power handling capacity with very low distortion.

TECHNICAL DATA

	version	
	M4	M8
Rated impedance	4	8 Ω
Voice coil resistance	3,8	7,5 Ω
Rated frequency range	50 to 12 000 Hz	
Resonance frequency	43 Hz	
Power handling capacity, mounted in 80 l sealed enclosure, measured without filter	30 W	
Maximum power on loudspeaker	60 W	
Operating power	6,2 W	
Sweep voltage	6,3	5,3 V
Maximum excursion voltage at 20 Hz	8,5	1,3 V
Energy in air gap	135	140 mJ
Flux density	0,87	0,93 T
Force factor (B x l) at 1 A	4	5,5 Wb/m
Total moving mass	12 g	
Compliance, loudspeaker unmounted	1,2 mm/N	
Quality factor		
mechanical	4,7	4,43
electrical	1,01	1,4
total	0,83	1,06
Air-gap length	1,2	1 mm
Air-gap height	5 mm	
Voice coil height	10 mm	
Core diameter	25 mm	
Magnet material	ceramic	
diameter	72	mm
mass	0,26	kg
Mass of loudspeaker	0,68	kg

The loudspeaker has a dual paper cone and a rubber surround. Two tinned 6,3 mm (0,25 inch) tag connectors permit connection to the speaker by plugging or soldering.

Dimensions in mm

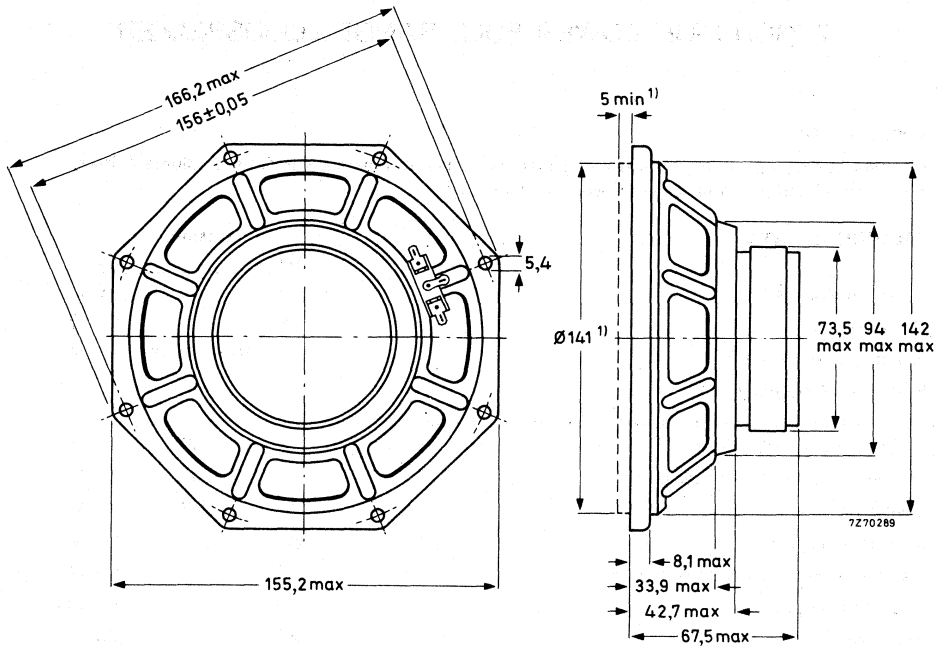

Fig. 1.

(1) Baffle hole and clearance depth required for cone movement at the specified power handling capacity.

One tag is indicated by a red mark for in-phase connection.

→ AVAILABLE VERSIONS

AD7062/M4, catalogue number 2404 257 46021
 AD7062/M8, catalogue number 2404 257 46022

} these numbers apply to bulk packed loudspeakers, minimum packing quantity 28 per unit.

FREQUENCY RESPONSE CURVE (see Fig. 2)

Curve b: Sound pressure measured in anechoic room at operating power. Loudspeaker mounted in sealed 80 l enclosure, filled with 1 kg of glass wool.

Curve c: 2nd and 3rd harmonic distortion, measured at the operating power of 5 W in anechoic room, loudspeaker mounted in sealed 80 l enclosure, filled with 1 kg of glass wool.

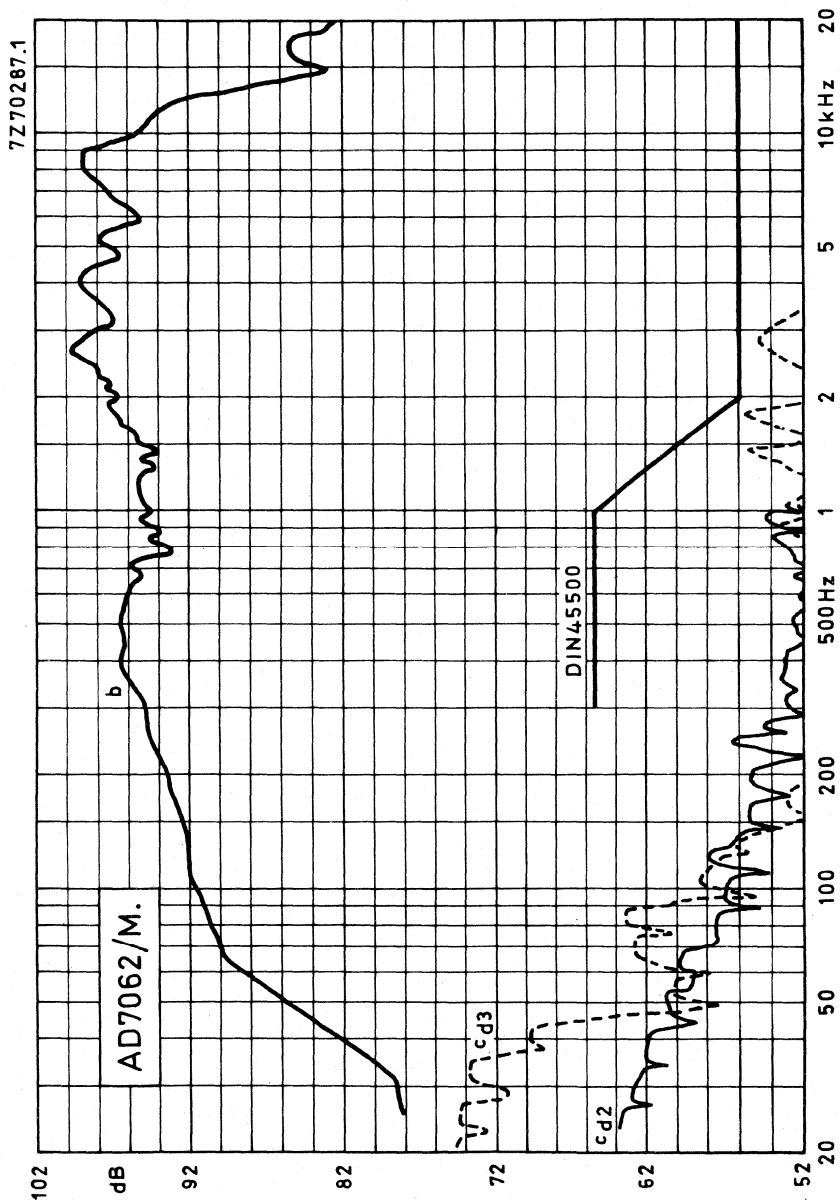

Fig. 2



7 INCH HIGH POWER FULL RANGE LOUDSPEAKER ←

APPLICATION

For high-fidelity bass reproduction in sealed acoustic enclosure. Recommended volume of enclosure 15 litres. The loudspeaker has a very low distortion.

TECHNICAL DATA

	version		
	M4	M8	
Rated impedance	4	8	Ω
Voice coil resistance	3,8	7,5	Ω
Rated frequency range	50 to 12 000		Hz
Resonance frequency	43		Hz
Power handling capacity, mounted in 80 l sealed enclosure, measured without filter	30		W
Maximum power on loudspeaker	60		W
Operating power	6,2		W
Sweep voltage	6,3	5,3	V
Maximum excursion voltage at 20 Hz	8,5	1,3	V
Energy in air gap	135	140	mJ
Flux density	0,87	0,93	T
Force factor (B x l) at 1 A	4	5,5	Wb/m ←
Total moving mass	12		g
Compliance, loudspeaker unmounted	1,2		mm/N
Quality factor			
mechanical	4,7	4,43	
electrical	1,01	1,4	
total	0,83	1,06	
Air-gap length	1,2	1	mm
Air-gap height	5		mm
Voice coil height	10		mm
Core diameter	25		mm
Magnet material	ceramic		
diameter	72		mm
mass	0,26		kg
Mass of loudspeaker	0,68		kg

The loudspeaker has a dual paper cone and a rubber surround. Two tinned 6,3 mm (0,25 inch) tag connectors permit connection to the speaker by plugging or soldering.

Dimensions in mm

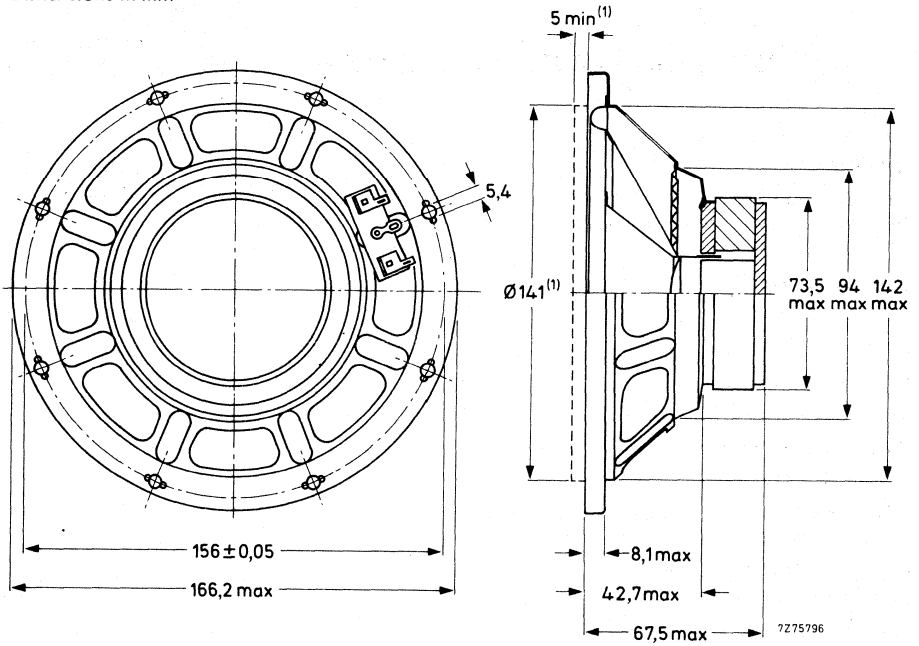

Fig. 1.

(1) Baffle hole and clearance depth required for cone movement at the specified power handling capacity.

One tag is indicated by a red mark for in-phase connection.

→ AVAILABLE VERSIONS

AD70620/M4, catalogue number 2404 257 46121

AD70620/M8, catalogue number 2404 257 46122

} these numbers apply to bulk packed loud speakers, minimum packing quantity 28 per unit.

FREQUENCY RESPONSE CURVE (See Fig. 2)

Measured in anechoic room at the operating power. Loudspeaker mounted in sealed 80 l enclosure, filled with 0,5 kg of glasswool.

Curve a: Sound pressure.

Curves d2 and d3: 2nd and 3rd harmonic distortion.

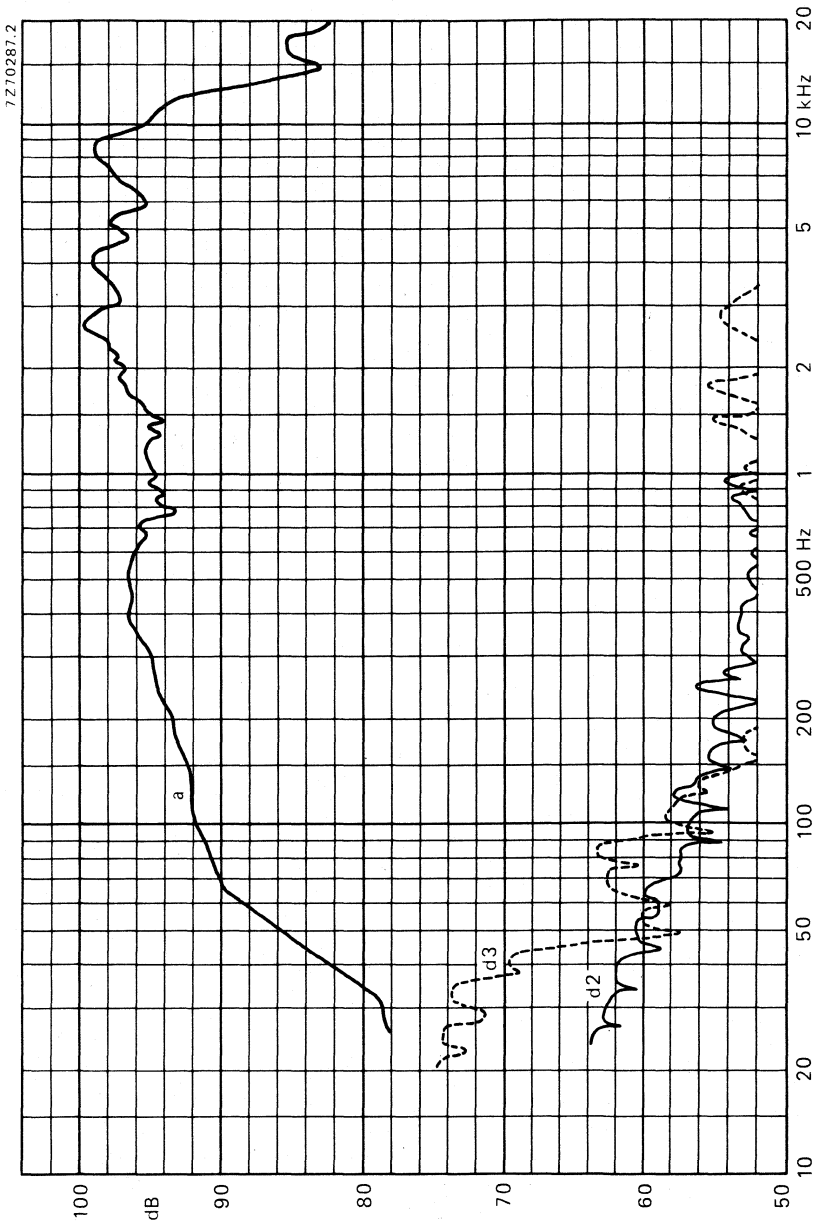

Fig. 2.



7 INCH HIGH POWER FULL RANGE LOUDSPEAKER

APPLICATION

For high fidelity reproduction in sealed acoustic enclosures. Maximum enclosure volume 25 litres.
Smooth response from 60 to 8000 Hz.

TECHNICAL DATA

	version	
	M4	M8
Rated impedance	4	8 Ω
Voice coil resistance	3,2	7 Ω
Resonance frequency	70	70 Hz
Power handling capacity, measured without filter, loudspeaker unmounted	10	10 W
Operating power	2,2	2,2 W
Sweep voltage	4,5	6,3 V
Energy in air gap	127	127 mJ
Flux density	0,87	0,87 T
Air-gap height	5	5 mm
Voice coil height	6	6,6 mm
Core diameter	25	25 mm
Magnet material	ceramic	ceramic
diameter	72	72 mm
mass	0,26	0,26 kg
Mass of loudspeaker	0,745	0,745 kg

The loudspeaker has a paper dual cone and a textile surround.

Connection to the loudspeaker by means of 6,3 mm (0,25 inch) tag connectors or by soldering.



Dimension in mm

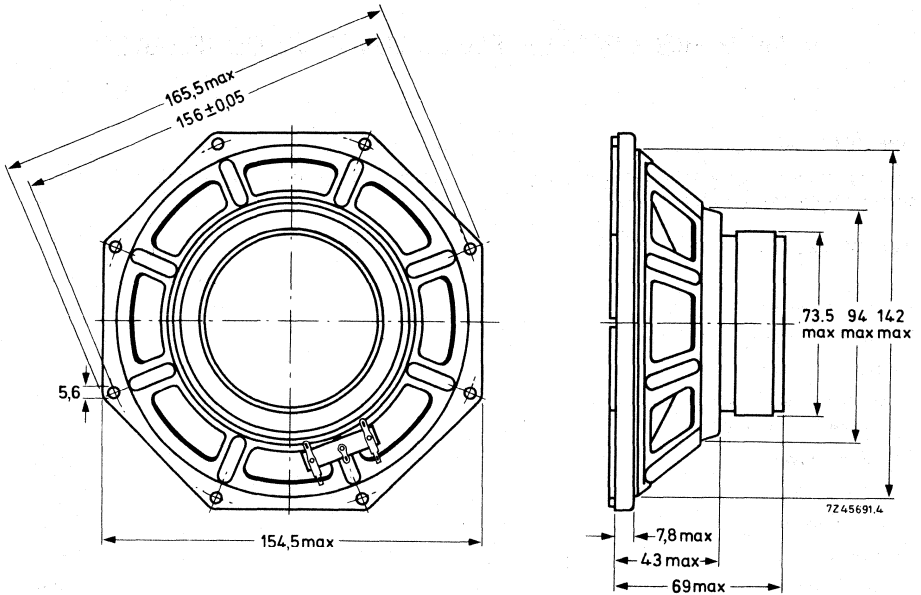

Fig. 1.

Baffle hole diameter 141 mm.

One tag is indicated by a red mark for in-phase connection.

→ AVAILABLE VERSIONS

AD7063/M4, catalogue number 2422 257 37926

AD7063/M8, catalogue number 2422 257 37927

} these numbers apply to bulk packed loudspeakers, minimum packing quantity 28 per unit.

FREQUENCY RESPONSE CURVES (see Fig. 2)

Curve b: Sound pressure measured in anechoic room at input power of 2,2 W. Loudspeaker mounted on IEC baffle.

Curve c: 2nd and 3rd harmonic distortion, measured at input power of 2,2 W in anechoic room. Loudspeaker mounted on IEC baffle.

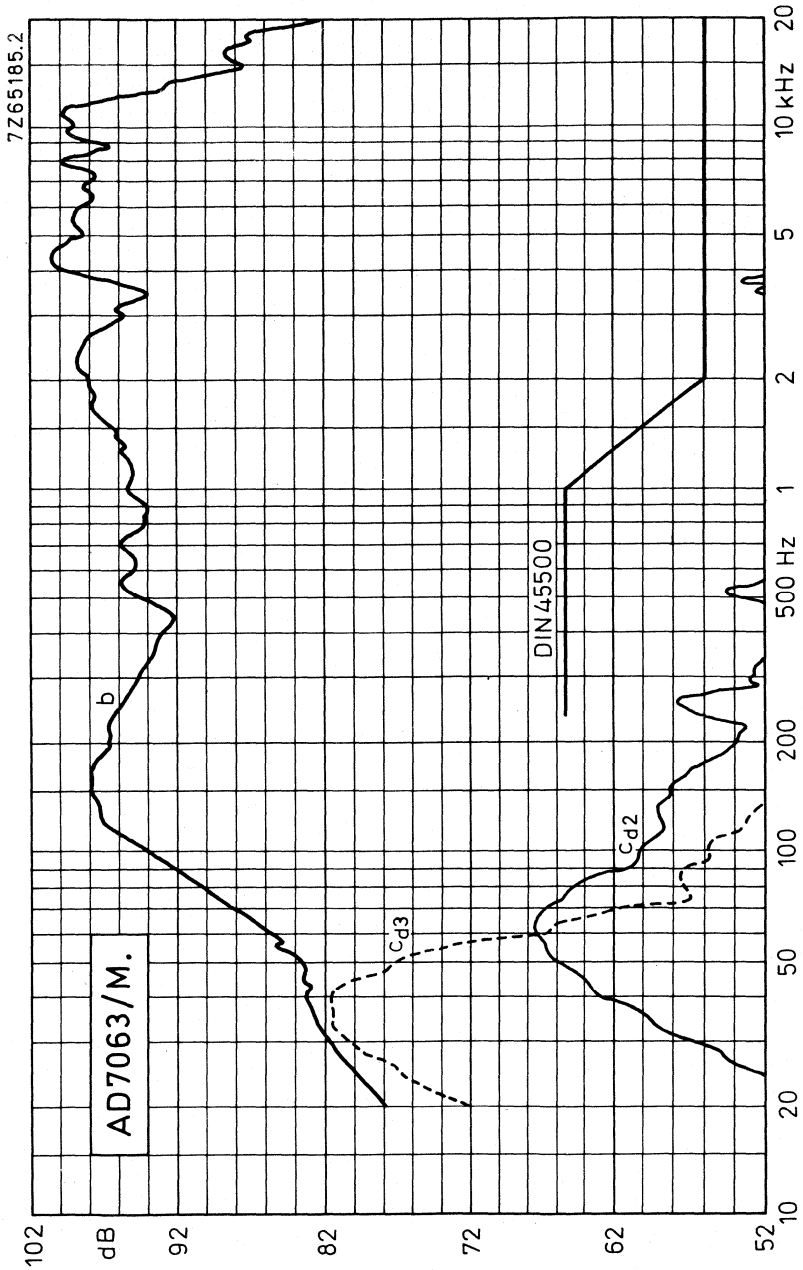

Fig. 2



7 inch HIGH POWER FULL RANGE LOUDSPEAKER

APPLICATION

For high fidelity reproduction in sealed acoustic enclosures. Maximum enclosure volume 25 litres.
Smooth response from 60 to 8000 Hz.

TECHNICAL DATA

	version	
	M4	M8
Rated impedance	4	8 Ω
Voice coil resistance	3,2	7 Ω
Rated frequency range	60 to 15 000 Hz	
Resonance frequency	70	Hz
Power handling capacity, measured without filter, loudspeaker unmounted	20	W
Operating power	3,05	3,15 W
Sweep voltage, frequency range: 35 to 20 000 Hz	4,5	6,3 V
Energy in air gap	127	mJ
Flux density	0,87	T
Air-gap height	5	mm
Voice coil height	6	6,3 mm
Core diameter	25	mm
Magnet material	ceramic	
diameter	72	mm
mass	0,26	kg
Mass of loudspeaker	0,745	kg

The loudspeaker has a paper dual cone and a textile surround. Connection to the loudspeaker by means of 6,3 mm (0,25 inch) tag connectors or by soldering.

Dimensions in mm

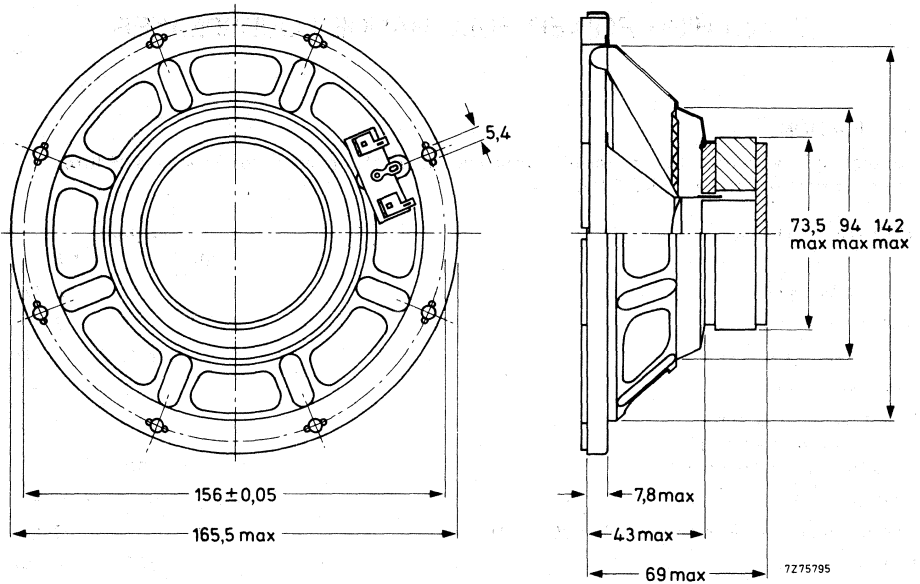

Fig. 1.

Baffle hole diameter 141 mm.

One tag is indicated by a red mark for in-phase connection.

→ AVAILABLE VERSIONS

AD70630/M4, catalogue number 2422 257 47123
 AD70630/M8, catalogue number 2422 257 47124

these numbers apply to bulk packed loudspeakers, minimum packing quantity 28 per unit.

FREQUENCY RESPONSE CURVES (see Fig. 2)

Measured in anechoic room at input power of 2,2 W. Loudspeaker mounted on IEC baffle.

Curve a: Sound pressure.

Curves d2 and d3: 2nd and 3rd harmonic distortion.

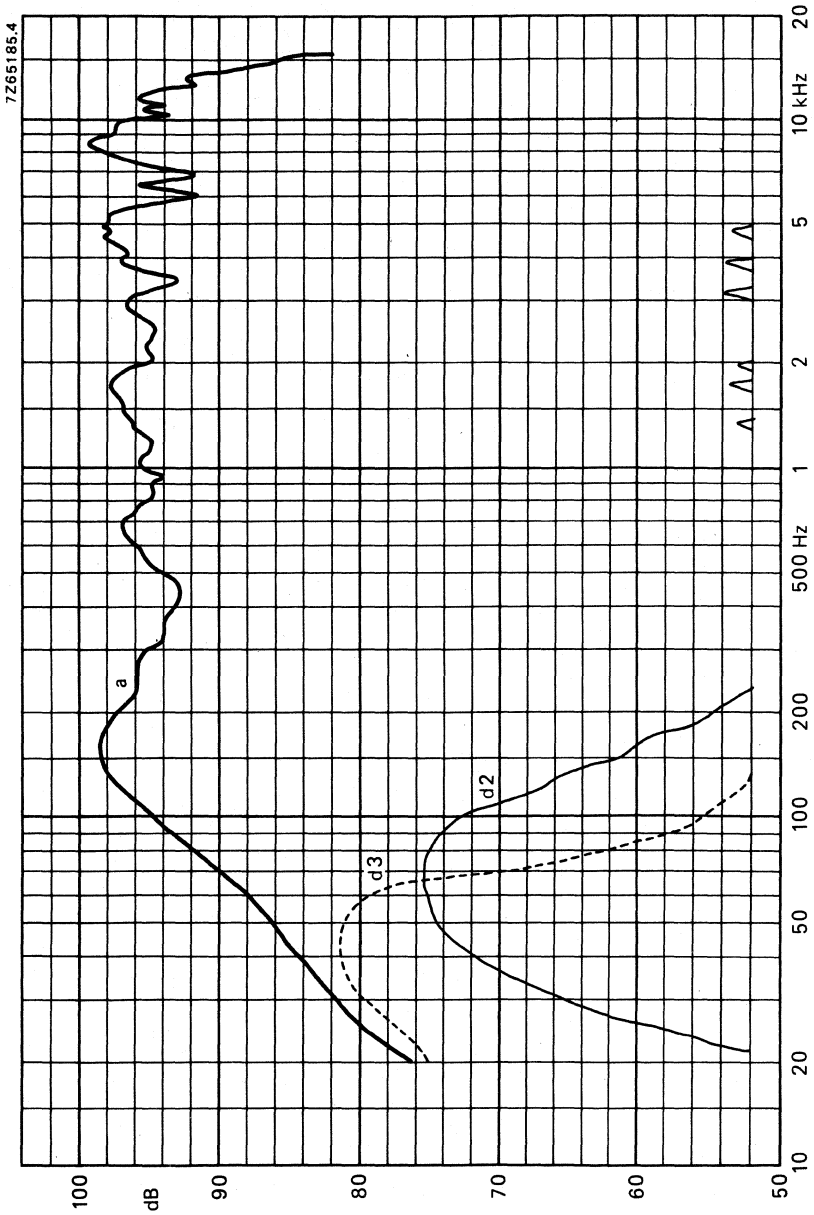

Fig. 2.



DEVELOPMENT SAMPLE DATA

This information is derived from development samples made available for evaluation. It does not necessarily imply that the device will go into regular production.

AD7064/M.

7 INCH HIGH POWER FULL RANGE LOUDSPEAKERS

APPLICATION

For high-fidelity sound reproduction in an enclosure. Recommended volume of enclosure 15 litres. The loudspeaker has a very low distortion.

TECHNICAL DATA

	version	
	M4	M8
Rated impedance	4	8 Ω
Voice coil resistance	3,2	7 Ω
Rated frequency range	50 to 15 000 Hz	
Resonance frequency	70	Hz
Power handling capacity, mounted in 15 l sealed enclosure, measured without filter	20	W
Maximum power on loudspeaker	3,05	3,15 W
Operating power	3	3,1
Sweep voltage, frequency range: 35 to 20 000 Hz	6,3	8,9 V
Energy in air gap	127	mJ
Flux density	0,87	T
Air-gap height	5	mm
Voice coil height	6	6,3 mm
Core diameter	25	mm
Magnet material	ceramic	
diameter	72	mm
mass	0,26	kg
Mass of loudspeaker	0,745	kg

The loudspeaker has a paper cone and a foam rubber surround. Two tinned 2,8 mm (0,11 inch) tag connectors permit connection to the loudspeaker by plugging or soldering. ←



Dimensions in mm

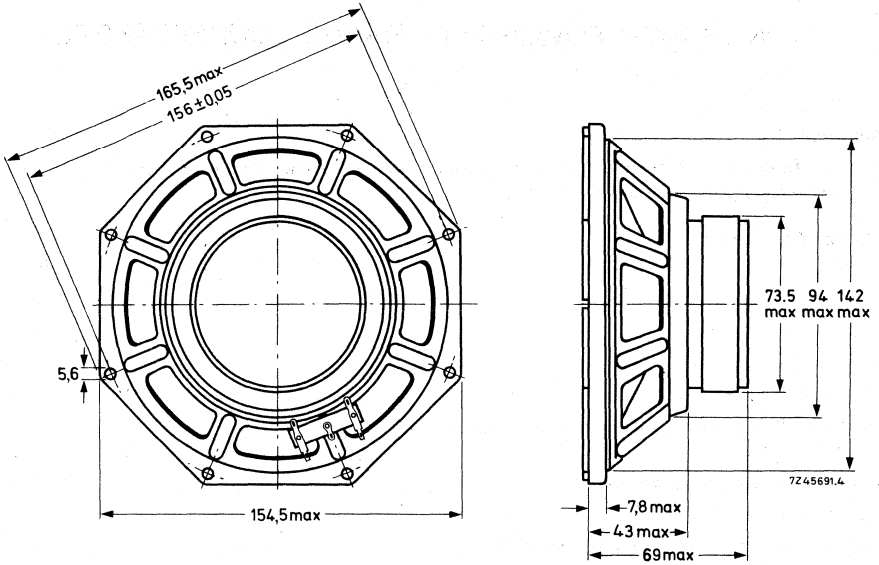

Fig. 1.

(1) Baffle-hole and clearance depth required for cone movement at the specified power handling capacity.

One tag is indicated by a red mark for in-phase connection.

→ AVAILABLE VERSIONS

AD7064/M4, catalogue number 2422 257 37933

AD7064/M8, catalogue number 2422 257 37934

these numbers apply to bulk packed loudspeakers, minimum packing quantity 28 per unit.

FREQUENCY RESPONSE CURVE (see Fig. 2)

Measured in anechoic room at the operating power. Loudspeaker mounted on IEC baffle acc. to IEC 268 - 5 par. 4-4.

Curve a: Sound pressure.

Curves d2 and d3: 2nd and 3rd harmonic distortion.

DEVELOPMENT SAMPLE DATA

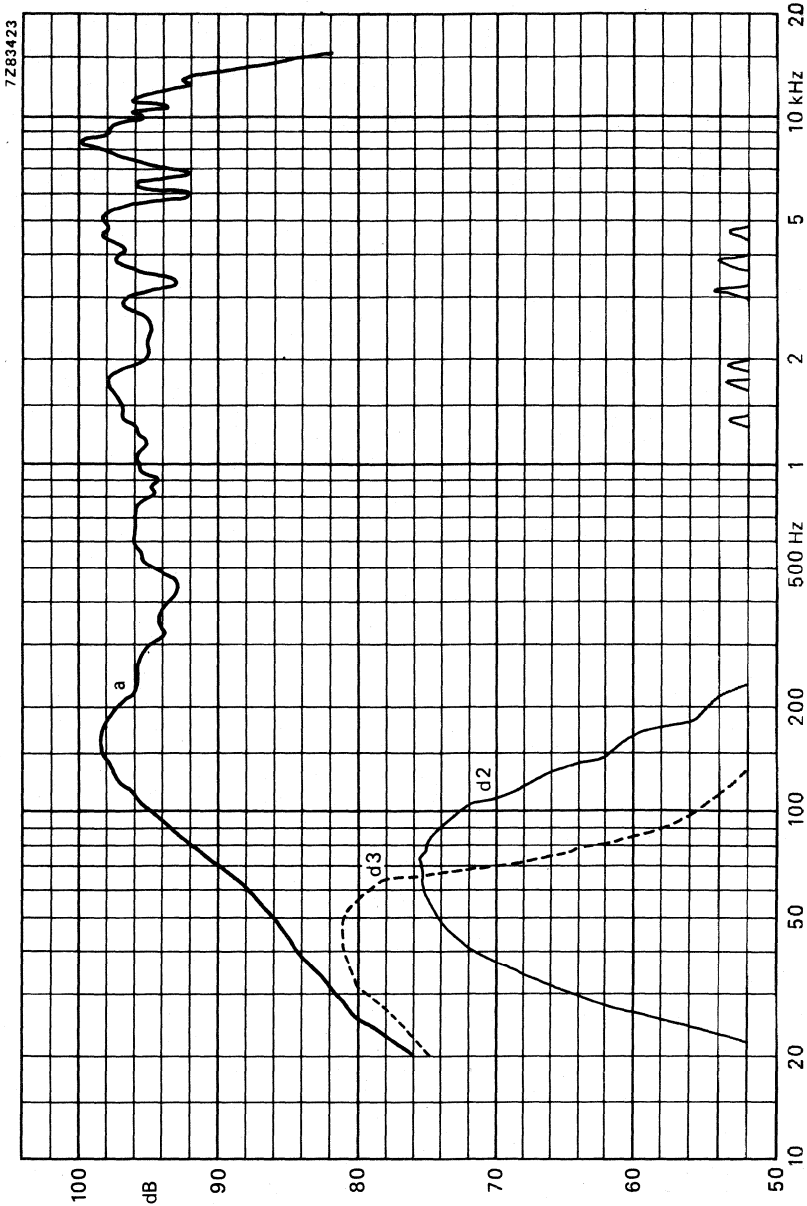

Fig. 2.



7 INCH HIGH POWER FULL RANGE LOUDSPEAKER

APPLICATION

For high fidelity reproduction in car radio applications.

TECHNICAL DATA

Rated impedance	4 Ω
Voice coil resistance	3,2 Ω
Rated frequency range	60 to 12 000 Hz
Resonance frequency	60 Hz
Power handling capacity, measured without filter, loudspeaker unmounted	20 W
Operating power	1,6 W
Sweep voltage	6,3 V
Energy in air gap	225 mJ
Flux density	1,12 T
Air-gap height	5 mm
Voice coil height	6 mm
Core diameter	25 mm
Magnet material	ceramic
diameter	72 mm
mass	0,26 kg
Mass of loudspeaker	0,745 kg

The loudspeaker has a paper dual cone and a textile surround. Connection to the loudspeaker by means of 6,3 mm (0,25 inch) tag connectors or by soldering.

AD7065/M4

Dimensions in mm

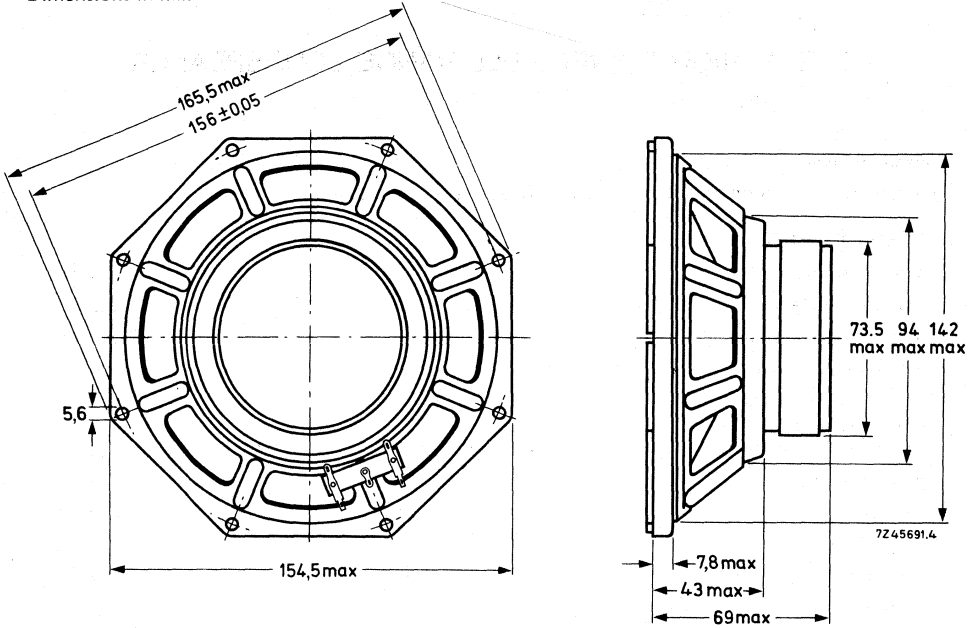

Fig. 1.

Baffle hole diameter 141 mm.

One tag is indicated by a red mark for in-phase connection.

→ AVAILABLE VERSION

AD7065/M4, catalogue number 2422 257 47039

this number applies to bulk packed loudspeakers, minimum packing quantity 12 per unit.

FREQUENCY RESPONSE CURVES (see Fig. 2)

Measured in anechoic room at input power of 1,6 W. Loudspeaker mounted on IEC baffle.

Curve a: Sound pressure.

Curves d2 and d3: 2nd and 3rd harmonic distortion.

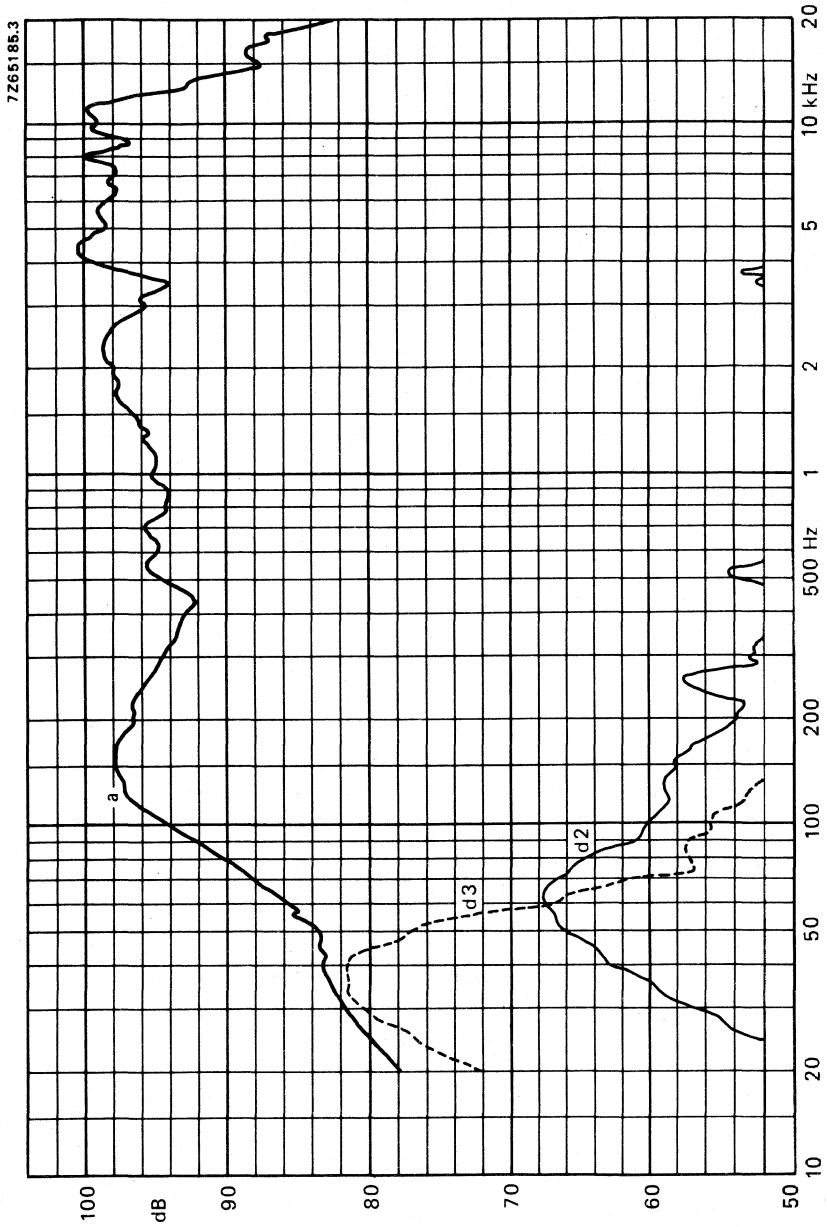

Fig. 2.



8½ inch HIGH POWER FULL RANGE LOUDSPEAKER

APPLICATION

A full range loudspeaker for studio monitoring equipment and domestic bass reflex enclosures for high fidelity reproduction from 45 Hz to 19 kHz.

TECHNICAL DATA

Rated impedance	8 Ω
Voice coil resistance	6,4 Ω
Frequency range	45 to 19 000 Hz
Resonance frequency	50 Hz
Power handling capacity measured without filter	
loudspeaker mounted in sealed enclosure < 30 l	20 W
loudspeaker mounted in sealed enclosure > 30 l	10 W
Operating power	1,3 W
Sweep voltage, frequency range: 35 to 20 000 Hz	6,3 V
Energy in air gap	203 mJ
Flux density	0,9 T
Air-gap height	6 mm
Voice coil height	8,9 mm
Core diameter	34 mm
Magnet material	ceramic
diameter	92 mm
mass	0,4 kg
Mass of loudspeaker	1,32 kg

The loudspeaker has a paper dual cone and surround and a cork gasket on the flange.

Connection to the loudspeaker by means of 2,8 mm (0,11 inch) tag connectors or by soldering.

Dimensions in mm

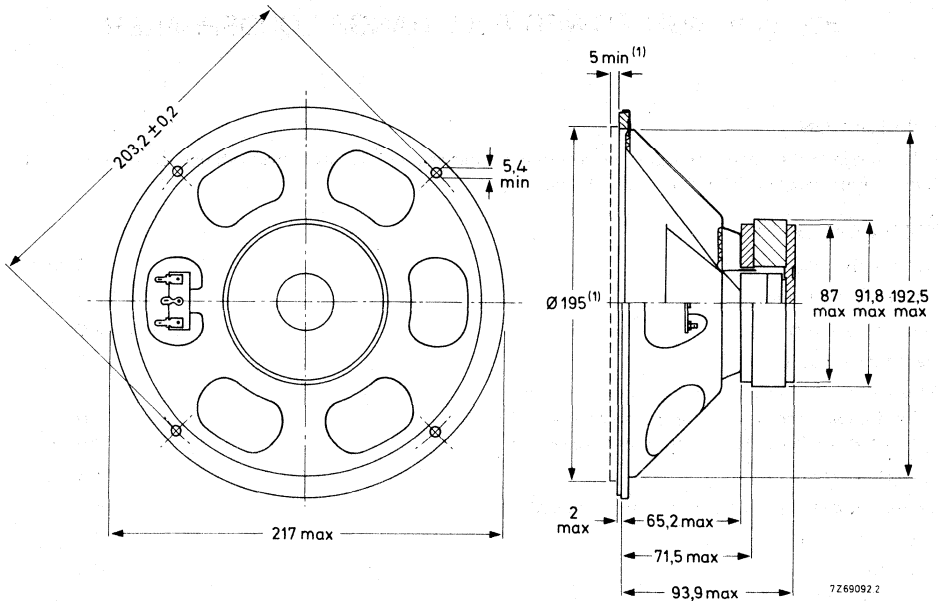

Fig. 1.

(1) Baffle hole and clearance depth required for cone movement at the specified power handling capacity.

One tag is indicated by a red mark for in-phase connection.

→ AVAILABLE VERSION

9710/M8, catalogue number 2422 257 48121

this number applies to bulk packed loudspeakers, minimum packing quantity 8 per unit.

FREQUENCY RESPONSE CURVES (see Fig. 2)

Curve a: Sound pressure measured in anechoic room, loudspeaker mounted on IEC baffle.

Curves d2 and d3: 2nd and 3rd harmonic distortion, measured at the operating power of 1,3 W in anechoic room, loudspeaker mounted in sealed 80 l enclosure, filled with 1 kg of glass wool.

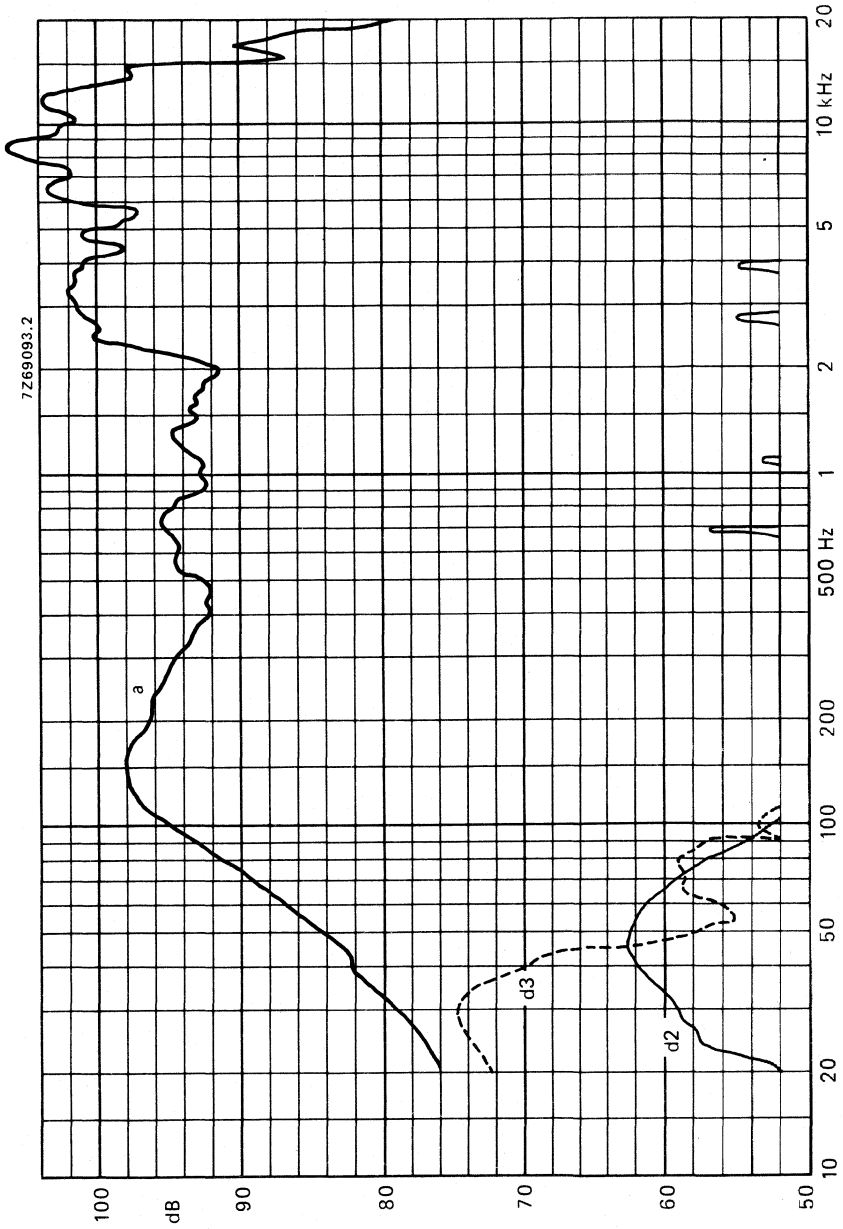

Fig. 2.



10 INCH HIGH POWER FULL RANGE LOUDSPEAKER

APPLICATION

A full range loudspeaker with high sensitivity for public address systems in enclosures greater than 20 litres.

Smooth response from 60 Hz to 18 000 Hz.

TECHNICAL DATA

	version		
	M4	M8	M15
Rated impedance	4	8	15 Ω
Voice coil resistance	3,4	7	13 Ω
Resonance frequency	55	55	55 Hz
Power handling capacity, measured without filter, loudspeaker unmounted	10	10	10 W
Operating power	1,5	1,5	1,5 W
Sweep voltage	4,5	6,3	8,7 V
Energy in air gap	225	225	225 mJ
Flux density	1,12	1,12	1,12 T
Air-gap height	5	5	5 mm
Voice coil height	6,5	6,5	4,5 mm
Core diameter	25	25	25 mm
Magnet material	ceramic	ceramic	ceramic
diameter	90	90	90 mm
mass	0,45	0,45	0,45 kg
Mass of loudspeaker	1,52	1,52	1,52 kg

The loudspeaker has a paper dual cone and surround and a foam plastic gasket on the flange. ←

Connection to the loudspeaker by means of 6,3 mm (0,25 inch) tag connectors or by soldering.

Dimensions in mm

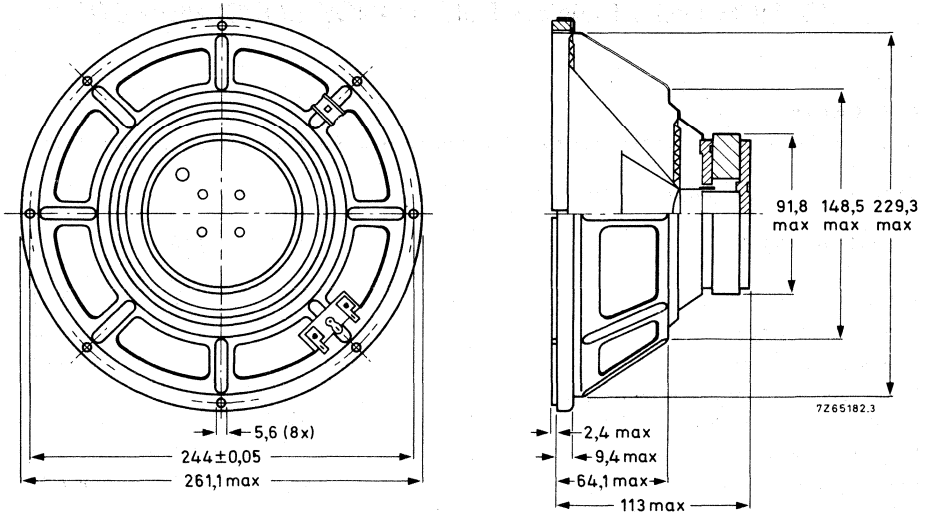

Fig. 1.

One tag is indicated by a red mark for in-phase connection.

→ AVAILABLE VERSIONS

- AD1065/M4, catalogue number 2422 257 41021
- AD1065/M8, catalogue number 2422 257 41022
- AD1065/M15, catalogue number 2422 257 41023

} these numbers apply to bulk packed loudspeakers, minimum packing quantity 4 per unit.

FREQUENCY RESPONSE CURVES (see Fig. 2)

Curve b: Sound pressure measured in anechoic room at operating power of 1,5 W. Loudspeaker mounted in sealed 80 l enclosure, filled with 1 kg of glass wool.

Curve c: 2nd and 3rd harmonic distortion, measured at operating power of 1,5 W in anechoic room. Loudspeaker mounted in 80 l enclosure, filled with 1 kg of glass wool.

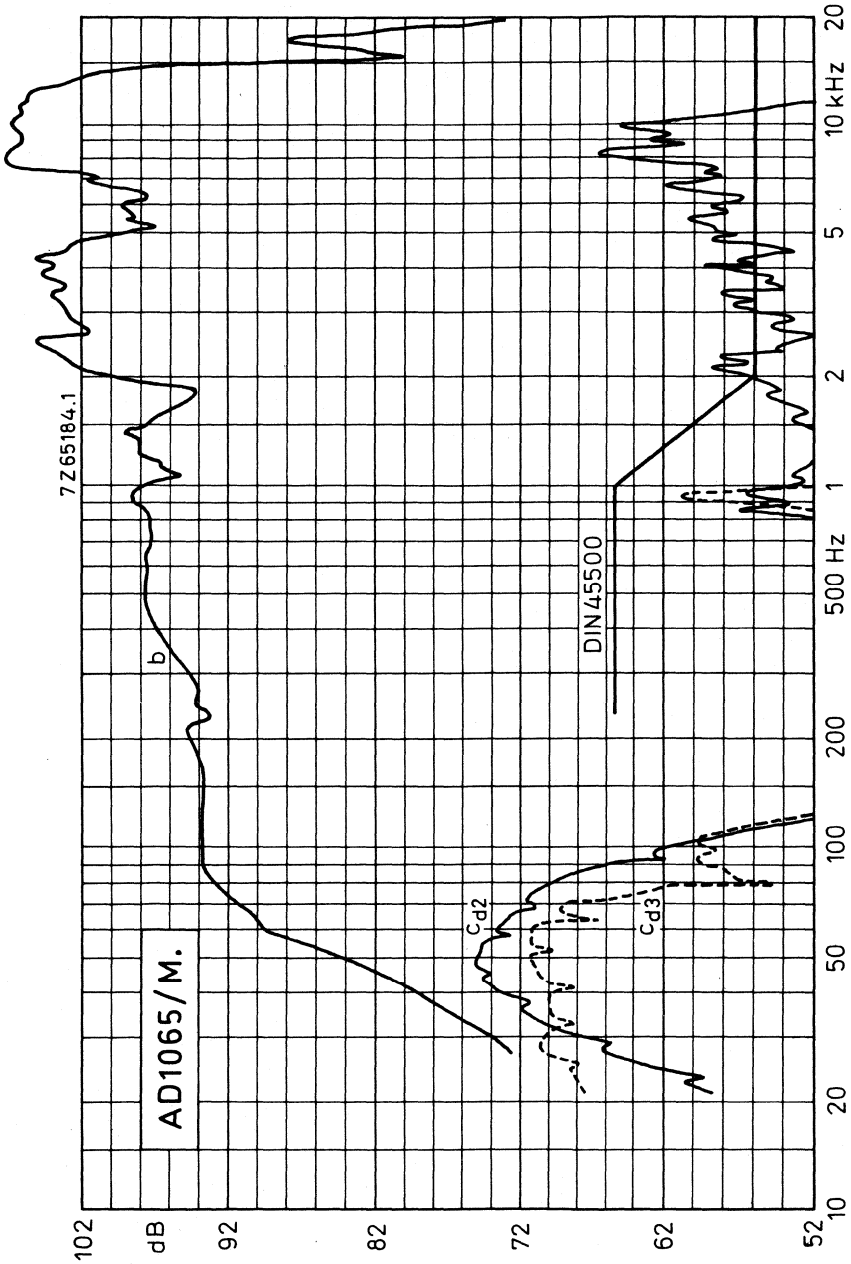

Fig. 2



12 INCH HIGH POWER FULL RANGE LOUDSPEAKER

APPLICATION

A dual cone loudspeaker for high power applications such as guitar amplifiers and electronic organs.

TECHNICAL DATA

	version	
	HP4	HP8
Rated impedance	4	8 Ω
Voice coil resistance	3,5	7,2 Ω
Rated frequency range	50 to 7000	Hz
Resonance frequency	60	Hz
Power handling capacity, loudspeaker unmounted measured without filter	50	W
Maximum power on loudspeaker	100	W
Operating power	1	0,8 W
Sweep voltage, frequency range: 35 to 20 000 Hz	10	14 V
Energy in air gap	820	mJ
Flux density	1,03	T
Force factor (B x l) at 1 A	11,5	Wb/m
Total moving mass	42	g
Compliance, loudspeaker unmounted	0,2	mm/N
Quality factor		
mechanical		7,6
electrical		1,1
total		0,96
Air-gap length	1,15	mm
Air-gap height	8	mm
Voice coil height	12,5	mm
Core diameter	50	mm
Magnet material	ceramic	
diameter	130	mm
mass	1	kg
Mass of loudspeaker	3,3	kg

The loudspeaker has a paper dual cone and a textile surround and a foam gasket on the flange.

Connection to the loudspeaker by means of 5,1 mm (0,2 inch) or 2,8 mm (0,11 inch) tag connectors or by soldering.

Dimensions in mm

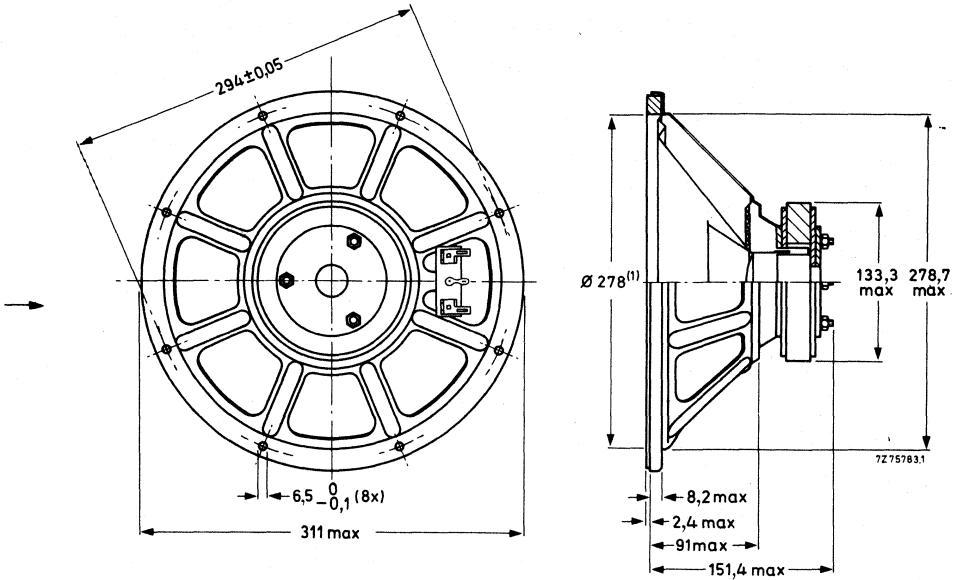

Fig. 1.

(1) Baffle hole diameter.

One tag is indicated by a red mark for in-phase connection.

→ AVAILABLE VERSIONS

AD12100/HP4, catalogue number 2422 257 51121
 AD12100/HP8, catalogue number 2422 257 51122

} these numbers apply to bulk packed loudspeakers, minimum packing quantity 3 per unit.

FREQUENCY RESPONSE CURVES (see Fig. 2)

Measured in anechoic room at the operating power. Loudspeaker mounted in sealed 80 l enclosure, filled with 1 kg of glass wool.

Curve a: Sound pressure.

Curves d2 and d3: 2nd and 3rd harmonic distortion.

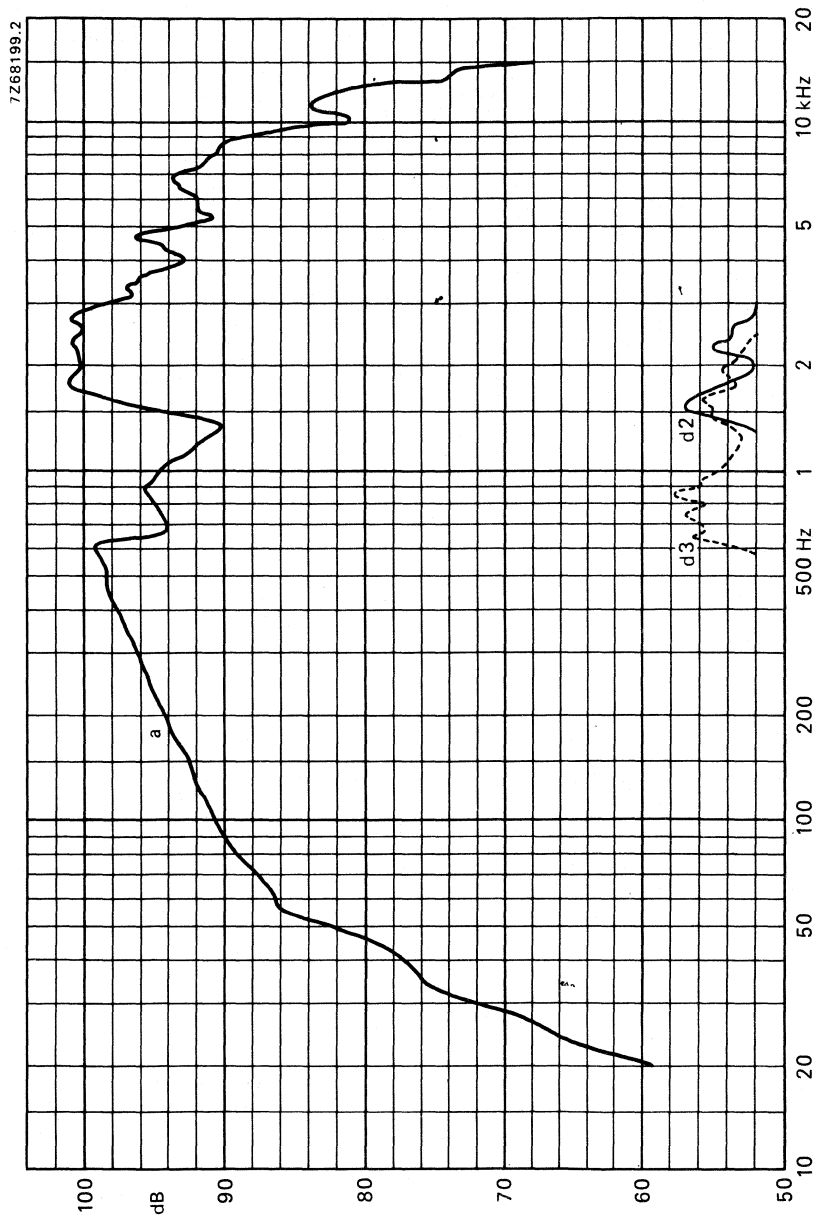

Fig. 2.



12 INCH HIGH POWER FULL RANGE LOUDSPEAKER

APPLICATION

A dual-cone loudspeaker with extremely high sensitivity for power applications such as public address systems, discotheques and domestic enclosures greater than 50 litres, and open baffles.

TECHNICAL DATA

	version		
	M4	M8	M15
Rated impedance	4	8	15 Ω
Voice coil resistance	3,2	7	13,2 Ω
Rated frequency range	50 to 12 000		Hz
Resonance frequency	45	55	45 Hz
Power handling capacity, loudspeaker unmounted measured without filter		25	W
Maximum power on loudspeaker		50	W
Operating power	0,55	0,5	0,6 W
Sweep voltage, frequency range: 35 to 20 000 Hz	6,3	9	12,2 V
Energy in air gap		970	mJ
Flux density		1,15	T
Force factor (B x l) at 1 A		10	Wb/m
Total moving mass		29,5	g
Compliance, loudspeaker unmounted		0,35	mm/N
Quality factor			
mechanical		8,2	
electrical		1,12	
total		0,98	
Air-gap length		1,15	mm
Air-gap height		8	mm
Voice coil height	9,1	10,3	13,3 mm
Core diameter		35	mm
Magnet material		ceramic	
diameter		130	mm
mass		1	kg
Mass of loudspeaker		3,3	kg

The loudspeaker has a paper dual cone and surround and a foam gasket on the flange. Connection to the loudspeaker by means of 5,1 mm (0,2 inch) or 2,8 mm (0,11 inch) tag connectors or by soldering.

Dimensions in mm

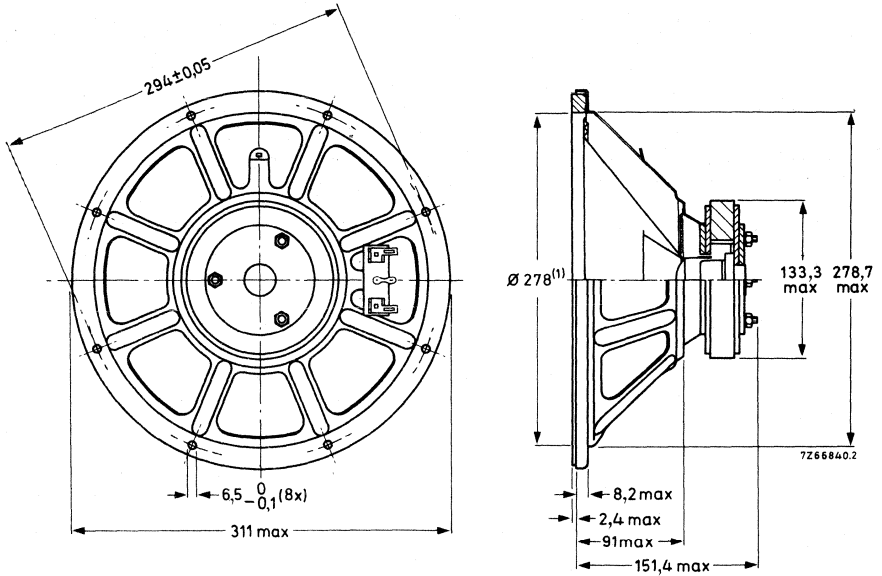

Fig. 1.

(1) Baffle hole diameter.

One tag is indicated by a red mark for in-phase connection.

→ AVAILABLE VERSIONS

AD12100/M4, catalogue number 2422 257 51021

AD12100/M8, catalogue number 2422 257 51022

AD12100/M15, catalogue number 2422 257 51023

these numbers apply to bulk packed loudspeakers, minimum packing quantity 3 per unit.

FREQUENCY RESPONSE CURVES (see Fig. 2)

Measured in anechoic room at the operating power. Loudspeaker mounted in sealed 80 l enclosure, filled with 1 kg of glass wool.

Curve a: Sound pressure.

Curves d2 and d3: 2nd and 3rd harmonic distortion.

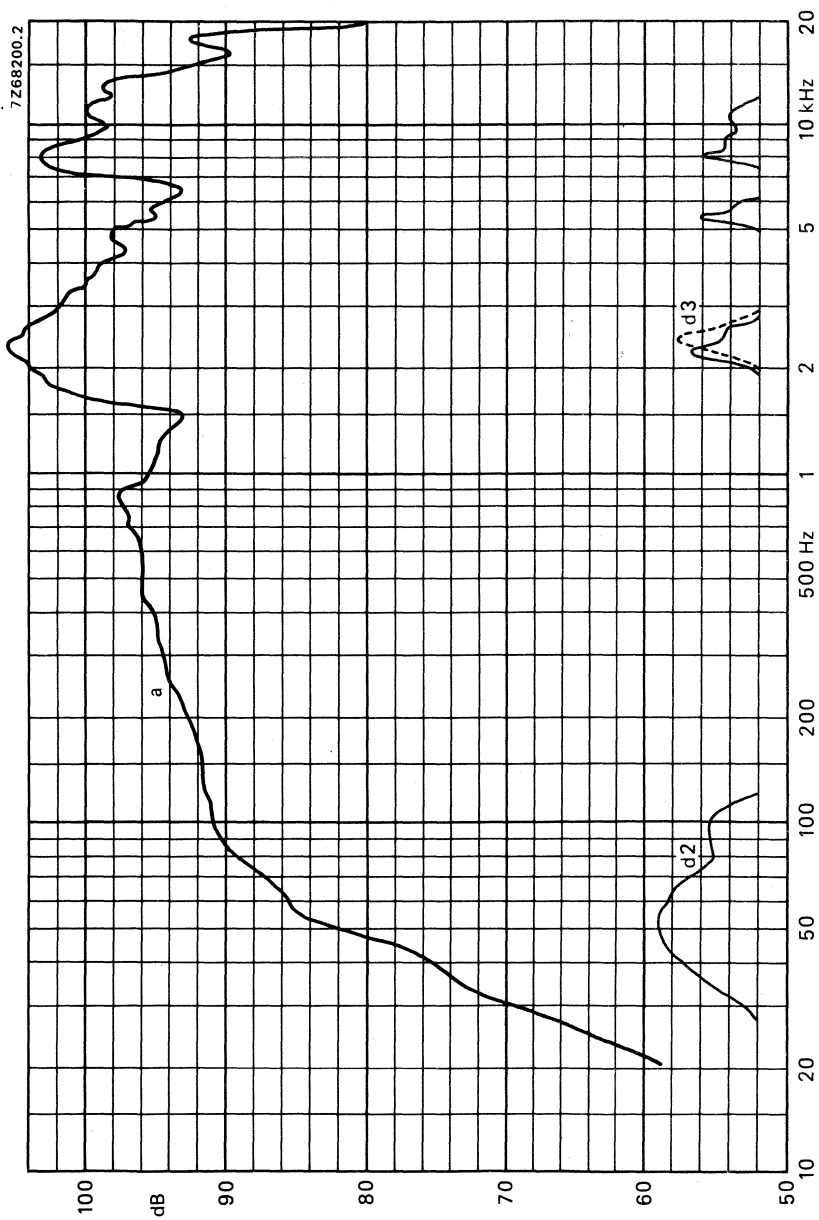

Fig. 2.



12 INCH HIGH POWER FULL RANGE LOUDSPEAKER

APPLICATION

Public address systems.

TECHNICAL DATA

	version		
	M4	M8	M15
Rated impedance	4	8	15 Ω
Voice coil resistance	3,4	7	13 Ω
Resonance frequency	45	45	45 Hz
Power handling capacity, measured without filter, loudspeaker unmounted	20	20	20 W
Operating power	1,44	1,44	1,44 W
Sweep voltage	6,3	9	12,2 V
Energy in air gap	225	225	225 mJ
Flux density	1,12	1,12	1,12 T
Air gap height	5	5	5 mm
Voice coil height	6,5	6,5	4,5 mm
Core diameter	25	25	25 mm
Magnet material	ceramic	ceramic	ceramic
diameter	90	90	90 mm
mass	0,45	0,45	0,45 kg
Mass of loudspeaker	1,8	1,8	1,8 kg

The loudspeaker has a paper dual cone and surround and a foam plastic gasket on the flange. ←

Connection to the loudspeaker by means of 6,3 mm (0,25 inch) tag connectors or by soldering.

Dimensions in mm

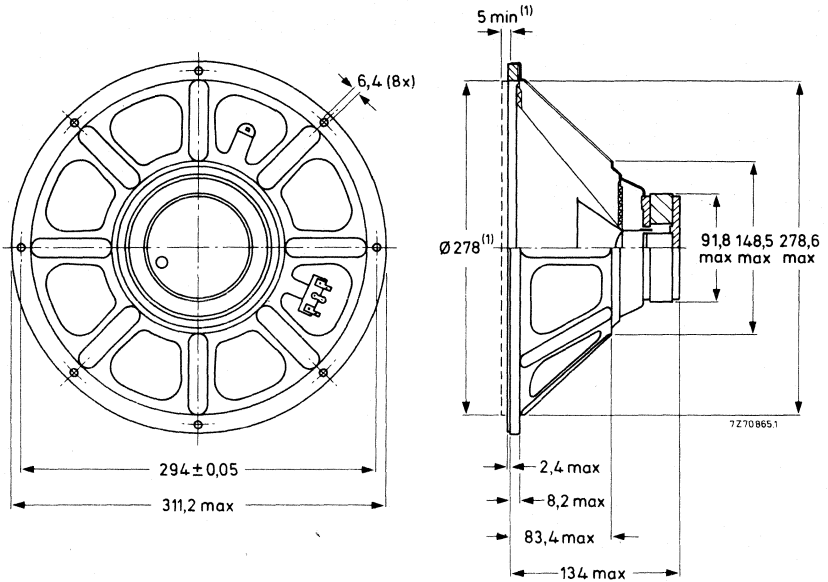

Fig. 1.

(1) Baffle hole and clearance depth required for cone movement at the specified power handling capacity.

One tag is indicated by a red mark for in-phase connection.

→ AVAILABLE VERSIONS

- AD1265/M4, catalogue number 2422 257 41121
- AD1265/M8, catalogue number 2422 257 41122
- AD1265/M15, catalogue number 2422 257 41123

} these numbers apply to bulk packed loudspeakers, minimum packing quantity 3 per unit.

FREQUENCY RESPONSE CURVES (see Fig. 2)

Curve b: Sound pressure measured in anechoic room at operating power of 1,44 W. Loudspeaker mounted in sealed 80 l enclosure, filled with 1 kg of glass wool.

Curve c: 2nd and 3rd harmonic distortion, measured at operating power of 1,44 W in anechoic room. Loudspeaker mounted in sealed 80 l enclosure, filled with 1 kg of glass wool.

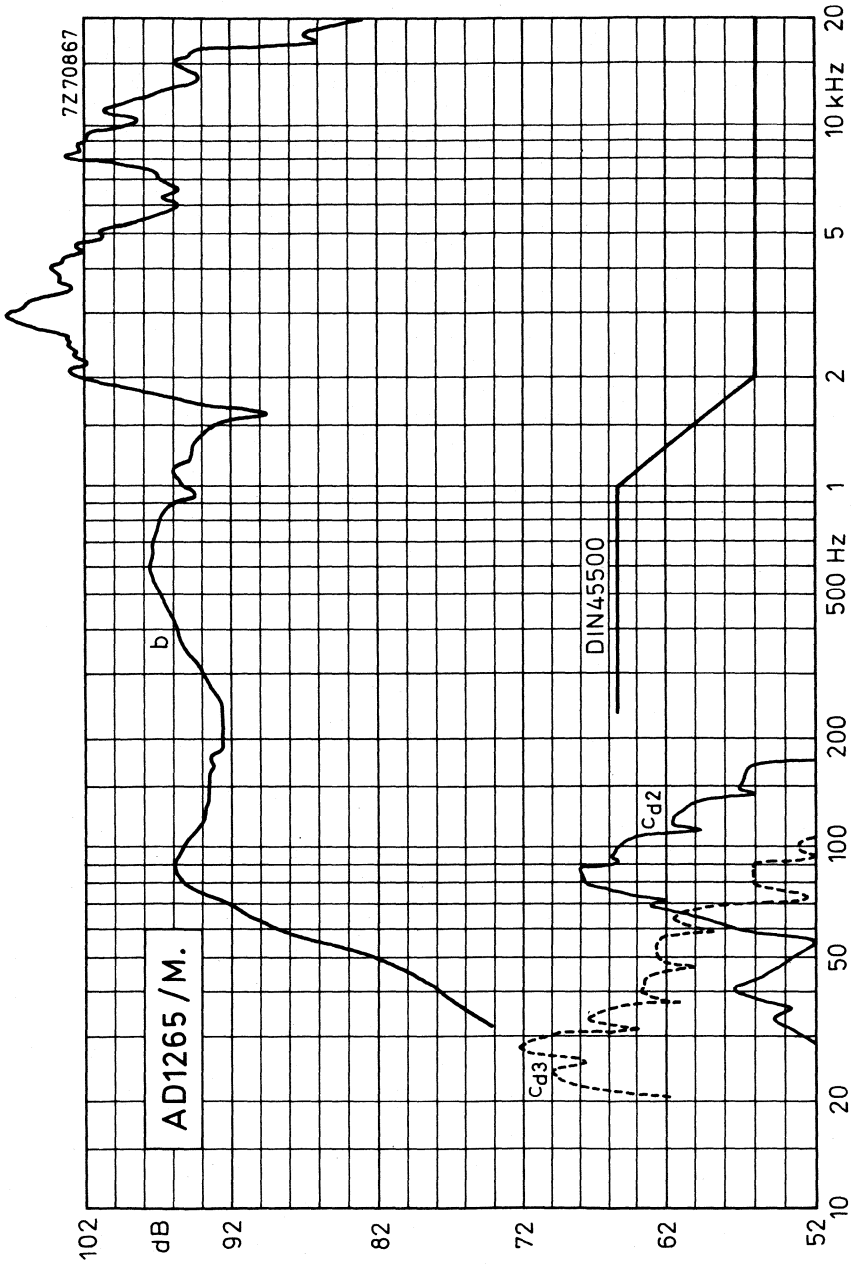

Fig. 2



HIGH POWER TWEETER LOUDSPEAKERS



770728-15-02

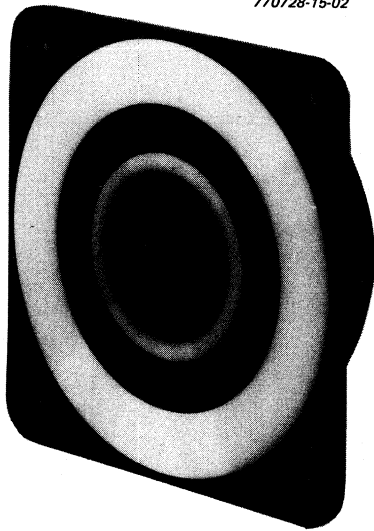

Type AD01605/T8



DEVELOPMENT SAMPLE DATA

This information is derived from development samples made available for evaluation. It does not necessarily imply that the device will go into regular production.

AD00400/T.

¾ INCH HIGH POWER DOME TWEETER LOUDSPEAKERS

APPLICATION

For the reproduction of frequencies from 2000 Hz to 20 000 Hz in three-way high-fidelity loudspeaker systems. Minimum recommended crossover frequency 2000 Hz with 12 dB/octave slope.

TECHNICAL DATA

	version	
	T4	T8
Rated impedance	4	8 Ω
Voice coil resistance	3,4	6,3 Ω
Rated frequency range	2000 to 20 000 Hz	
Resonance frequency	1700	Hz ←
Power handling capacities, a/b (see Fig. 1), loudspeaker unmounted, C = 6,8 μF; L = 0,2 mH	50/6	W
C = 3,3 μF; L = 0,35 mH		50/6 W
Operating power	8	W
Maximum power	12	W
Sweep voltage, frequency range: 1000 to 20 000 Hz high pass filter: 6,8 μF – 0,2 mH	3	V
3,3 μF – 0,35 mH		4,5 V
Energy in air gap	78,4	mJ
Flux density	1,25	T
Air-gap height	2,5	mm
Voice coil height	3	3 mm
Core diameter	18	mm
Magnet material	ceramic	
diameter	60	mm
mass	0,15	kg ←
Mass of loudspeaker	0,32	kg

The loudspeaker has an impregnated textile dome. Two tinned 2,8 mm (0,11 inch) tag connectors permit connection to the tweeter by plugging or soldering.

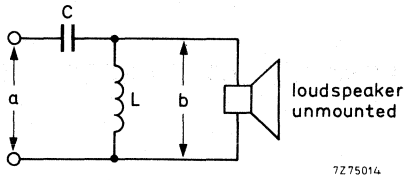

Fig. 1 Measuring circuit.
 a = system power handling capacity.
 b = loudspeaker power handling capacity.

Dimensions in mm

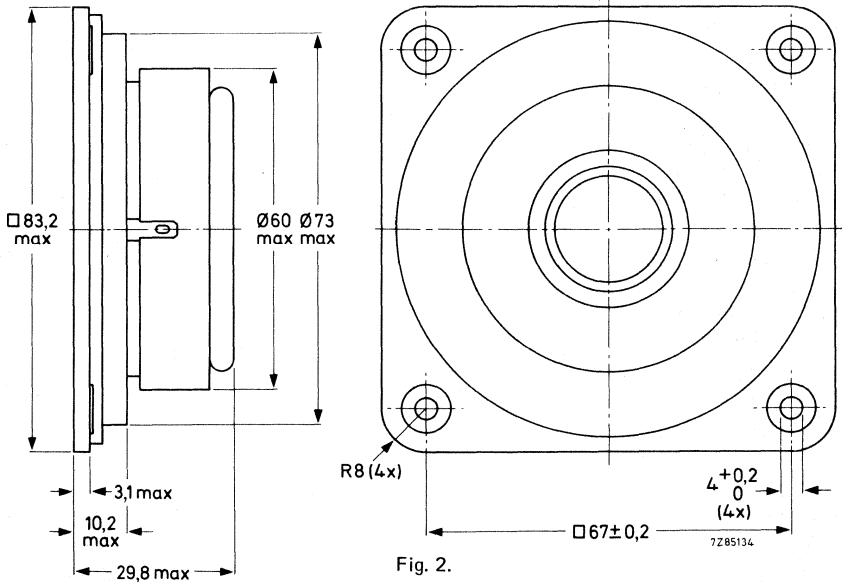

Fig. 2.

One tag is indicated by a red mark for in-phase connection. Face of loudspeaker should lie in line with plane of baffle.

→ AVAILABLE VERSIONS

- AD00400/T4 catalogue number 2422 257 33721
- AD00400/T8 catalogue number 2422 257 33722

} these numbers apply to bulk packed loudspeakers, minimum packing quantity 36 per unit.

FREQUENCY RESPONSE CURVES (see Fig. 3)

Measured in anechoic room at the operating power. Loudspeaker mounted on IEC baffle.

Curve a: Sound pressure.

Curves d2 and d3: 2nd and 3rd harmonic distortion.

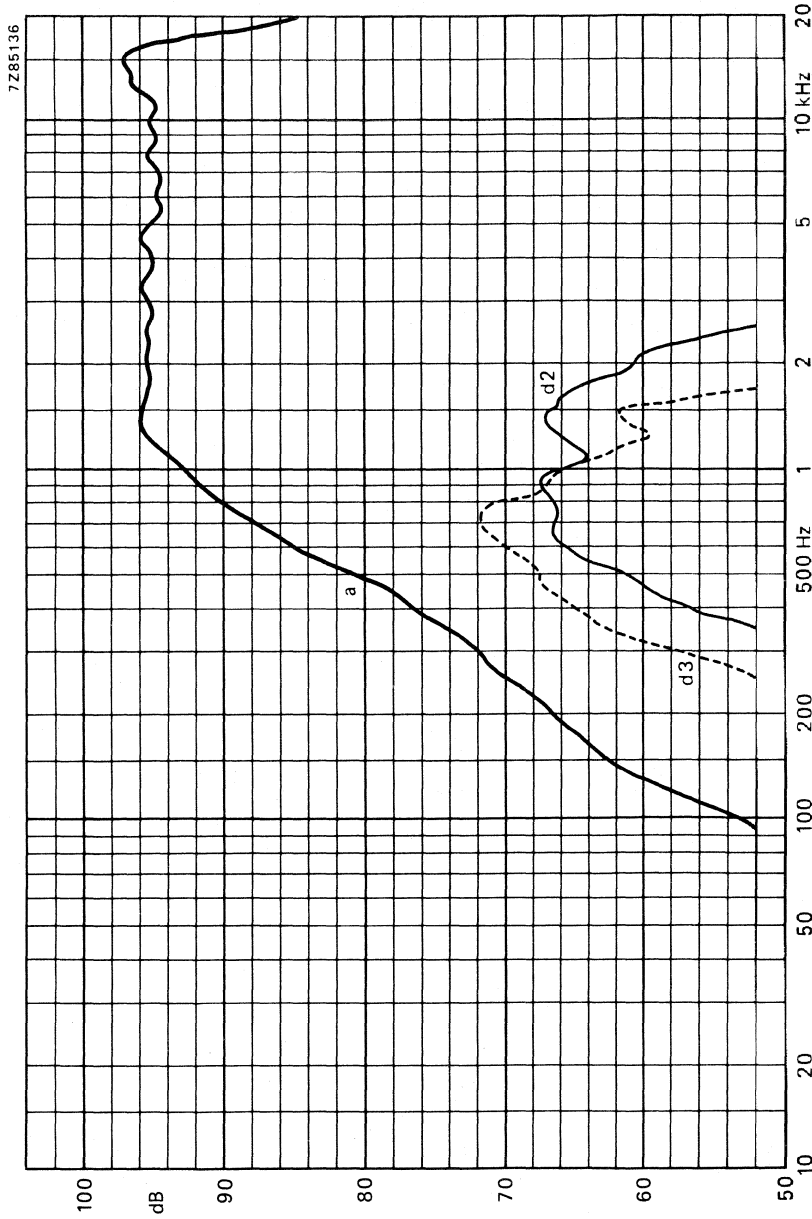

Fig. 3.



DEVELOPMENT SAMPLE DATA

This information is derived from development samples made available for evaluation. It does not necessarily imply that the device will go into regular production.

ADO0800/T.

3/4 INCH HIGH POWER DOME TWEETER LOUDSPEAKERS

APPLICATION

For the reproduction of frequencies from 2000 Hz to 20 000 Hz in multi-way high-fidelity loudspeaker systems. Minimum recommended crossover frequency 2000 Hz with 12 dB/octave slope.

TECHNICAL DATA

	version		
	T4	T8	
Rated impedance	4	8 Ω	
Voice coil resistance	3,4	6,3 Ω	
Rated frequency range	2000 to 20 000 Hz		
Resonance frequency	1700	Hz	←
Power handling capacities, a/b (see Fig. 1), loudspeaker unmounted, C = 6,8 μF; L = 0,2 mH C = 3,3 μF; L = 0,35 mH	50/6	W 50/6 W	
Operating power		3 W	←
Maximum power		12 W	
Sweep voltage, frequency range: 1000 to 20 000 Hz high pass filter: 6,8 μF — 0,2 mH 3,3 μF — 0,35 mH	3	V 4,5 V	
Energy in air gap		55,3 mJ	
Flux density		1,05 T	
Air-gap height		2,5 mm	
Voice coil height	3	3 mm	
Core diameter		18 mm	
Magnet material		ceramic	
diameter		53 mm	
mass		0,1 kg	←
Mass of loudspeaker		0,22 kg	

The loudspeaker has an impregnated textile dome. Two tinned 2,8 mm (0,11 inch) tag connectors permit connection to the tweeter by plugging or soldering.

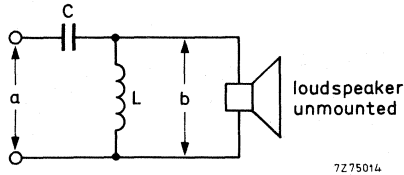
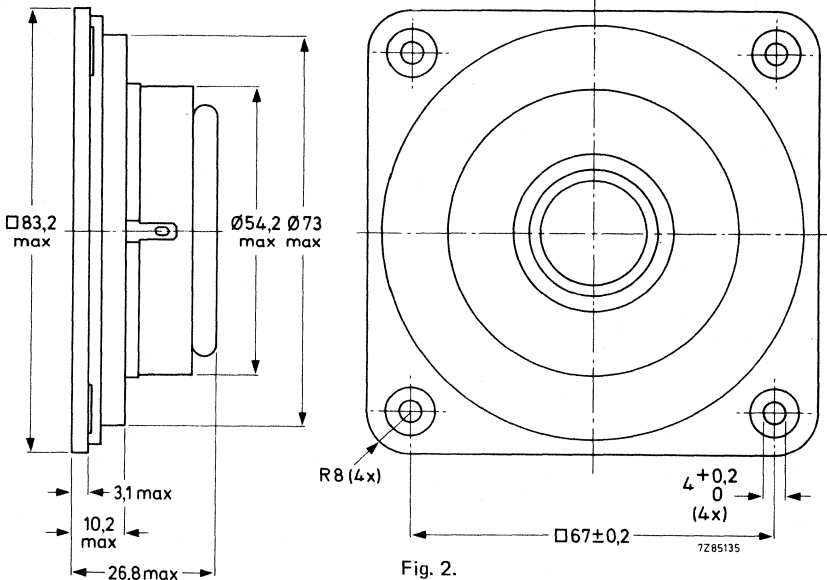

Fig. 1 Measuring circuit.
 a = system power handling capacity.
 b = loudspeaker power handling capacity.

Dimensions in mm



One tag is indicated by a red mark for in-phase connection. Face of loudspeaker should lie in line with plane of baffle.

→ AVAILABLE VERSIONS

- AD00800/T4 catalogue number 2422 257 33731
- AD00800/T8 catalogue number 2422 257 33732

} these numbers apply to bulk packed loudspeakers, minimum packing quantity 36 per unit.

FREQUENCY RESPONSE CURVES (see Fig. 3)

Measured in anechoic room at the operating power. Loudspeaker mounted on IEC baffle.

Curve a: Sound pressure.

Curves d2 and d3: 2nd and 3rd harmonic distortion.

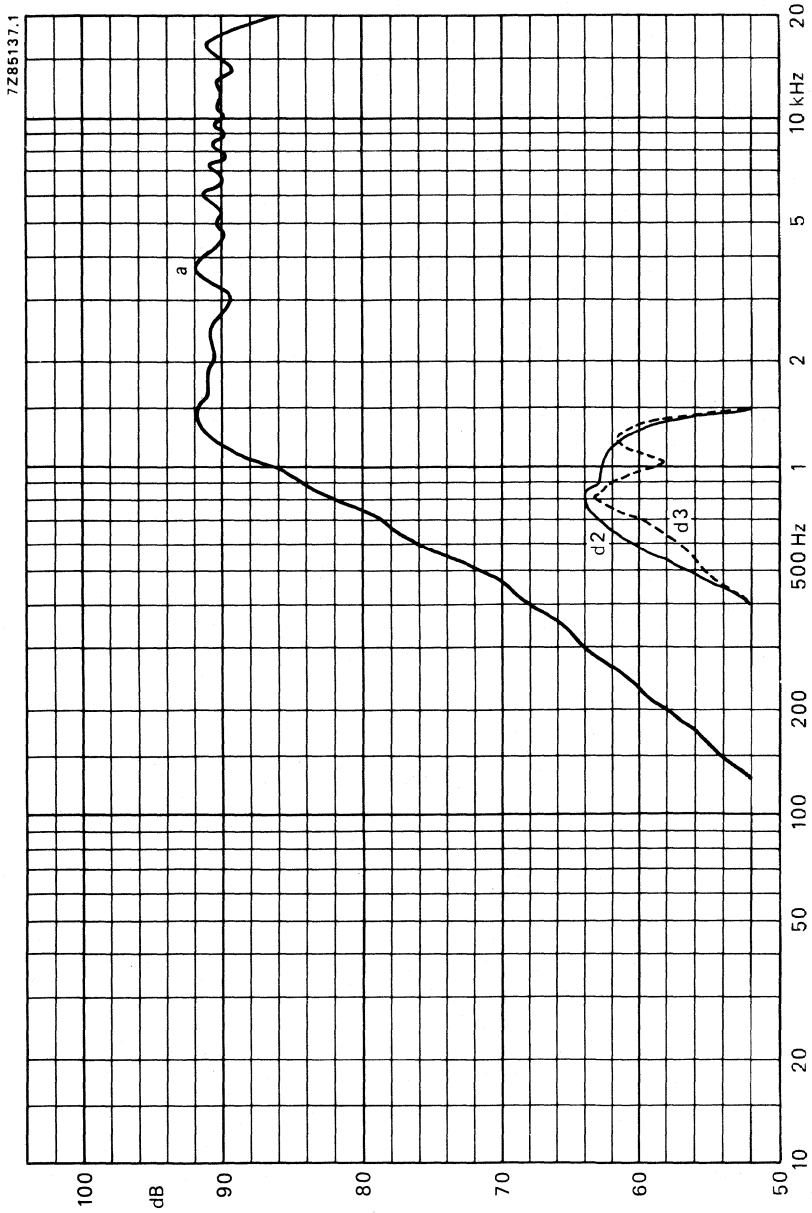

Fig. 3.



DEVELOPMENT SAMPLE DATA

This information is derived from development samples made available for evaluation. It does not necessarily imply that the device will go into regular production.

AD00900/T.

3/4 INCH HIGH POWER DOME TWEETER LOUDSPEAKERS

APPLICATION

For the reproduction of frequencies from 2000 Hz to 20 000 Hz in multi-way high-fidelity loudspeaker systems. Minimum recommended crossover frequency 2000 Hz with 12 dB/octave slope.

TECHNICAL DATA

	version	
	T4	T8
Rated impedance	4	8 Ω
Voice coil resistance	3,4	6,3 Ω
Rated frequency range	3000 to 20 000 Hz	
Resonance frequency	1900 Hz	
Power handling capacities, a/b (see Fig. 1), loudspeaker unmounted, C = 6,8 μ F; L = 0,2 mH	50/6	W
C = 3,3 μ F; L = 0,35 mH		50/6 W
Operating power	12	W
Maximum power	12	W
Sweep voltage, frequency range: 1000 to 20 000 Hz high pass filter: 6,8 μ F — 0,2 mH	3	V
3,3 μ F — 0,35 mH		4,5 V
Energy in air gap	55,3	mJ
Flux density	1,05	T
Air-gap height	2,5	mm
Voice coil height	3	3 mm
Core diameter	18	mm
Magnet material	ceramic	
diameter	45	mm
mass	0,102	kg
Mass of loudspeaker	0,3	kg

The loudspeaker has an impregnated textile dome. Two tinned 2,8 mm (0,11 inch) tag connectors permit connection to the tweeter by plugging or soldering.

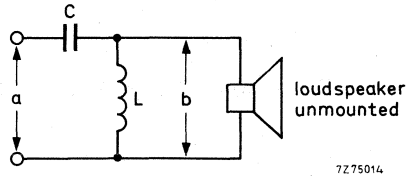

Fig. 1 Measuring circuit.
 a = system power handling capacity.
 b = loudspeaker power handling capacity.

Dimensions in mm

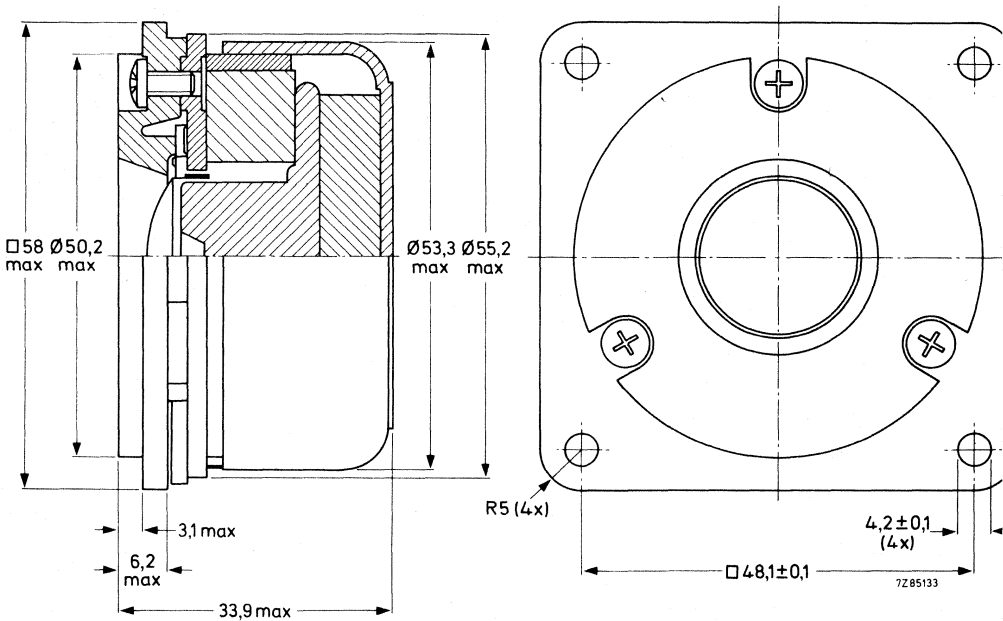

Fig. 2.

One tag is indicated by a red mark for in-phase connection. Face of loudspeaker should lie in line with plane of baffle.

→ AVAILABLE VERSIONS

- AD00900/T4 catalogue number 2422 257 43121
- AD00900/T8 catalogue number 2422 257 43122

} these numbers apply to bulk packed loudspeakers, minimum packing quantity 36 per unit.

FREQUENCY RESPONSE CURVES (see Fig. 3)

Measured in anechoic room at the operating power. Loudspeaker mounted on IEC baffle.

Curve a: Sound pressure.

Curves d2 and d3: 2nd and 3rd harmonic distortion.

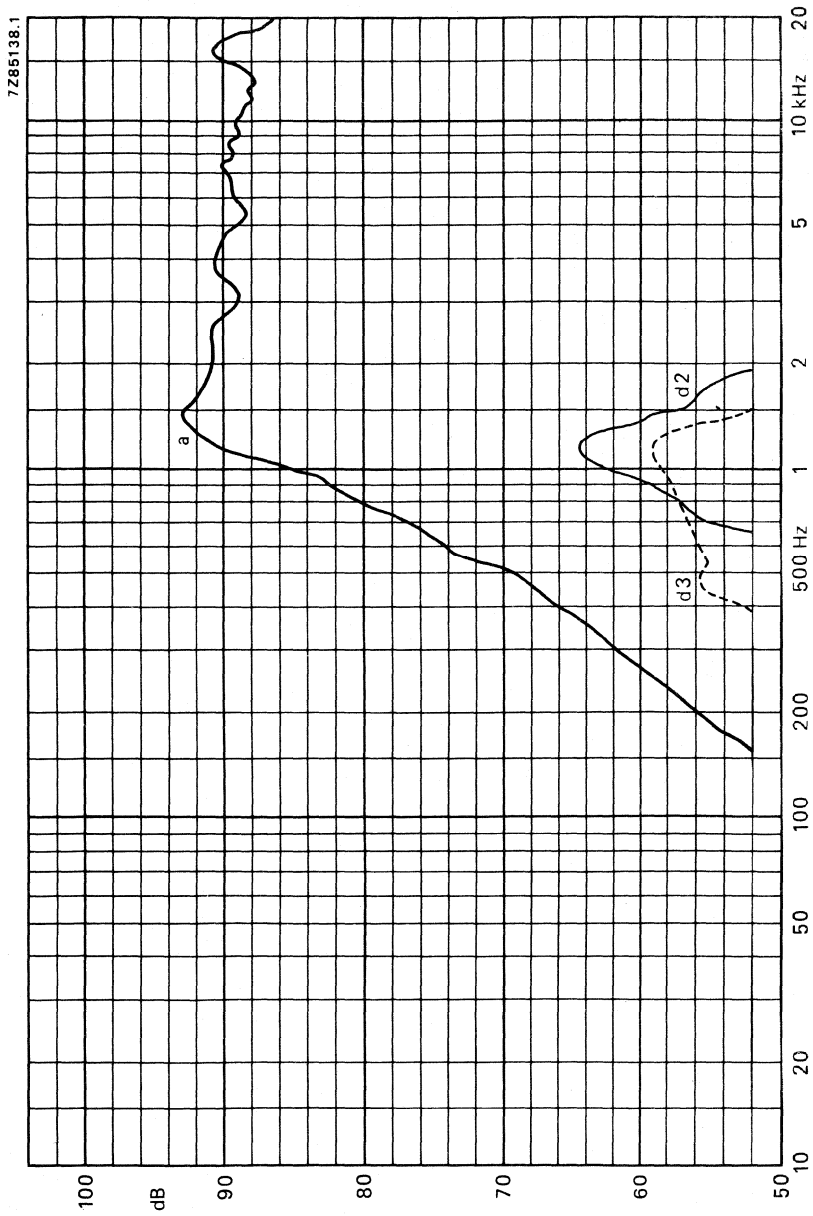

Fig. 3.



1 INCH HIGH POWER DOME TWEETER LOUDSPEAKER

APPLICATION

For the reproduction of audio frequencies from 1600 Hz to 22 000 Hz in multi-way high-fidelity loudspeaker systems. Minimum recommended cross-over frequency 1600 Hz with 12 dB/octave slope.

TECHNICAL DATA

	version	
	T4	T8
Rated impedance	4	8 Ω
Voice coil resistance	3,4	6,3 Ω
Rated frequency range	1600 to 20 000 Hz	
Resonance frequency	1200 Hz	
Power handling capacity, a/b (see Fig. 1), loudspeaker mounted on IEC baffle,		
at 2000 Hz 12 μ F-0,35 mH	20/4	W
at 4000 Hz 5 μ F-0,2 mH	40/5	W
at 2000 Hz 8 μ F-0,5 mH		20/4 W
at 4000 Hz 3,2 μ F-0,35 mH		40/5 W
Operating power	4 W	
Sweep voltage (500 to 20 000 Hz)		
high pass filter:		
12 μ F-0,35 mH	3	V
8 μ F-0,5 mH		4,5 V
Energy in air gap	58,5 mJ	
Flux density	0,9 T	
Air-gap height	2,5 mm	
Voice coil height	2,4	3,2 mm
Core diameter	25 mm	
Magnet material	ceramic	
diameter	60 mm	
mass	0,1 kg	
Mass of loudspeaker	0,25 kg	

The loudspeaker has a polycarbonate dome and a voice coil of aluminium wire.

Connection to the loudspeaker is by means of 2,8 mm (0,11 inch) tag connectors or by soldering.

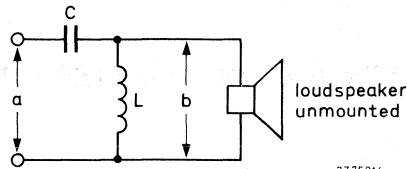

Fig. 1 Measuring circuit.
 a = system power handling capacity.
 b = loudspeaker power handling capacity.

Dimensions in mm

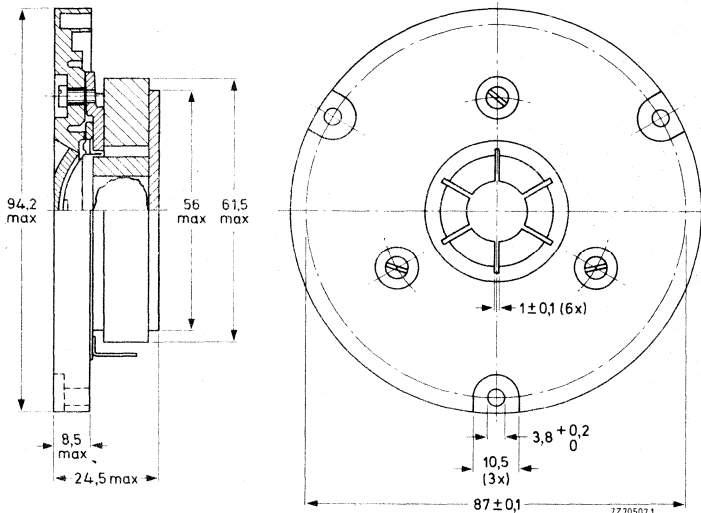

Fig. 2.

One tag is indicated by a red mark for in-phase connection. Baffle hole diameter 75 mm. Face of loudspeaker should lie in line with plane of baffle.

AVAILABLE VERSIONS

AD0140/T4, catalogue number 2422 257 33221
 AD0140/T8, catalogue number 2422 257 33222

these numbers apply to bulk packed loudspeakers, minimum packing quantity 36 per unit.

FREQUENCY RESPONSE CURVES (See Fig. 3)

Curve a: Sound pressure measured in half free field, input at operating power. Loudspeaker mounted on baffle, dimensions 50 x 50 mm.

Curves d2 and d3: 2nd and 3rd harmonic distortion, measured at the operating power of 4 W in anechoic room. Loudspeaker unmounted.

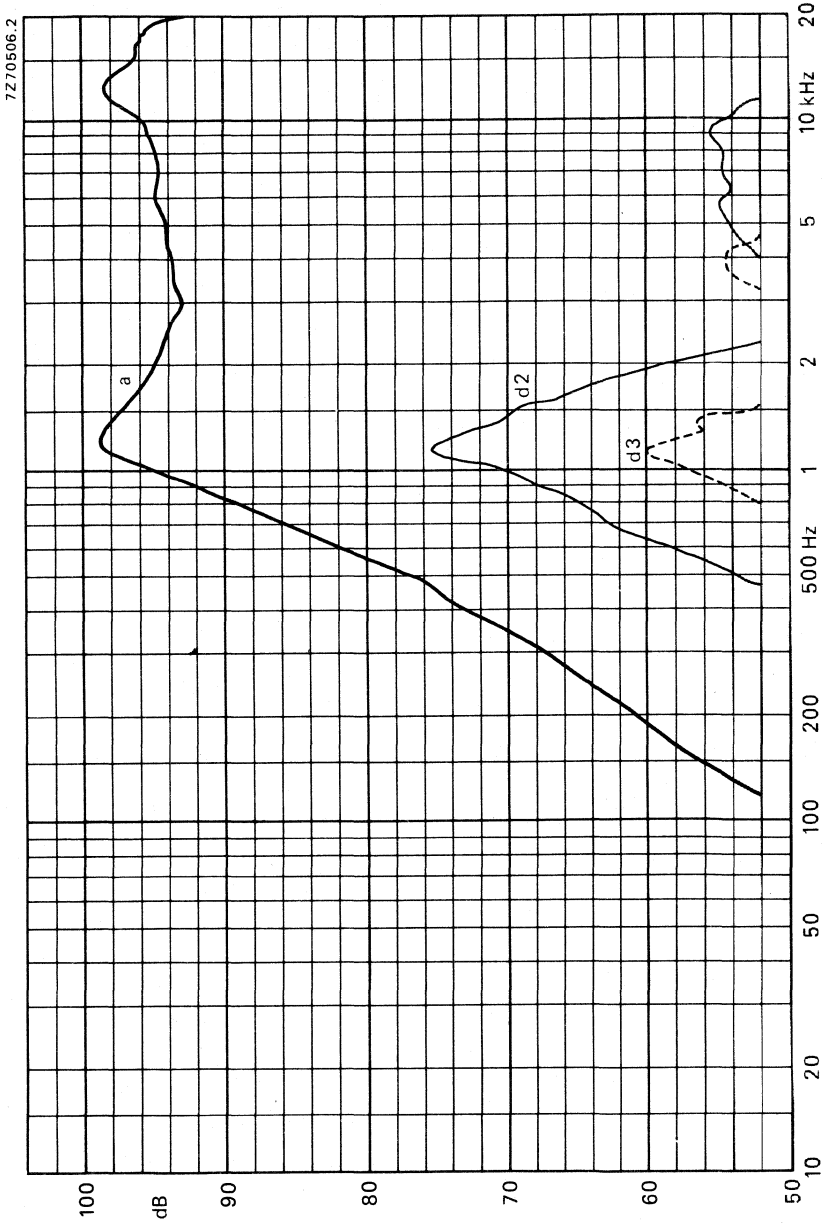

Fig. 3.



DEVELOPMENT SAMPLE DATA

This information is derived from development samples made available for evaluation. It does not necessarily imply that the device will go into regular production.

AD01404/T.

1 INCH FERROFLUID DOME TWEETER LOUDSPEAKER

APPLICATION

For the reproduction of high frequencies in multi-way high-fidelity loudspeaker systems. Minimum recommended crossover frequency 2000 Hz with 12 dB/octave slope.

TECHNICAL DATA

	version	
	T4	T8
Rated impedance	4	8 Ω
Voice coil resistance	3,4	6,3 Ω
Rated frequency range	2000 to 22 000 Hz	
Resonance frequency	1600	Hz
Power handling capacities, a/b (see Fig. 1), loudspeaker unmounted		
C = 12 μ F; L = 0,35 mH	20/4	W
C = 5 μ F; L = 0,2 mH	50/6	W
C = 8 μ F; L = 0,5 mH		20/4 W
C = 3,2 μ F; L = 0,35 mH		50/6 W
Operating power	4	W
Sweep voltage, frequency range: 500 to 20 000 Hz, high pass filter:		
12 μ F - 0,35 mH	3	V
8 μ F - 0,5 mH		4,5 V
Energy in air gap	58,5	mJ
Flux density	0,9	T
Air-gap height	2,5	mm
Voice coil height	2,4	3,2 mm
Core diameter	25	mm
Magnet material	ceramic	
diameter	60	mm
mass	0,1	kg
Mass of loudspeaker	0,25	kg

The loudspeaker has a polycarbonate dome and a diffuser integrated in the cover. Two tinned 2,8 mm (0,11 inch) tag connectors permit connection to the tweeter by plugging or soldering.

Fig. 1 Measuring circuit.
 a = system power handling capacity.
 b = loudspeaker power handling capacity.

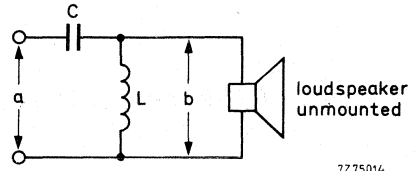

7275014

Dimensions in mm

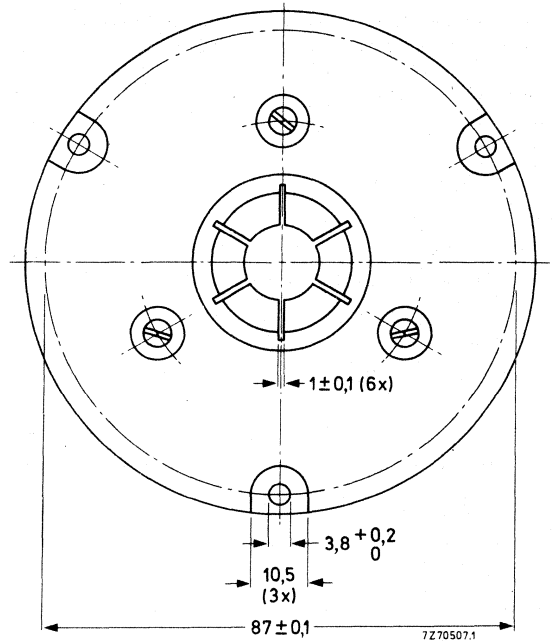
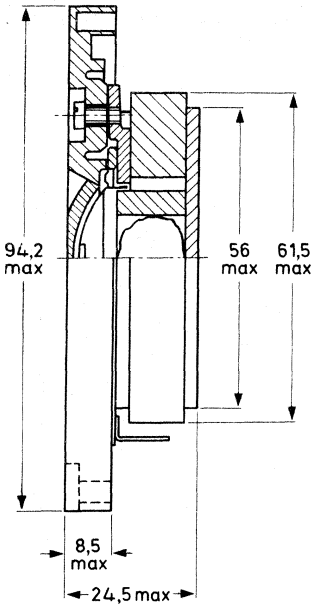

7270507.1

Fig. 2.

One tag is indicated by a red mark for in-phase connection. Face of loudspeaker should not lie behind plane of baffle.

AVAILABLE VERSIONS

- AD01404/T4, catalogue number 2422 257 33228
- AD01404/T8, catalogue number 2422 257 33229

these numbers apply to bulk packed loudspeakers, minimum packing quantity 36 per unit.

FREQUENCY RESPONSE CURVES (See Fig. 3)

Measured in anechoic room at the operating power. Loudspeaker mounted on IEC baffle.
 Curve a: Sound pressure.
 Curve d2: 2nd harmonic distortion.

DEVELOPMENT SAMPLE DATA

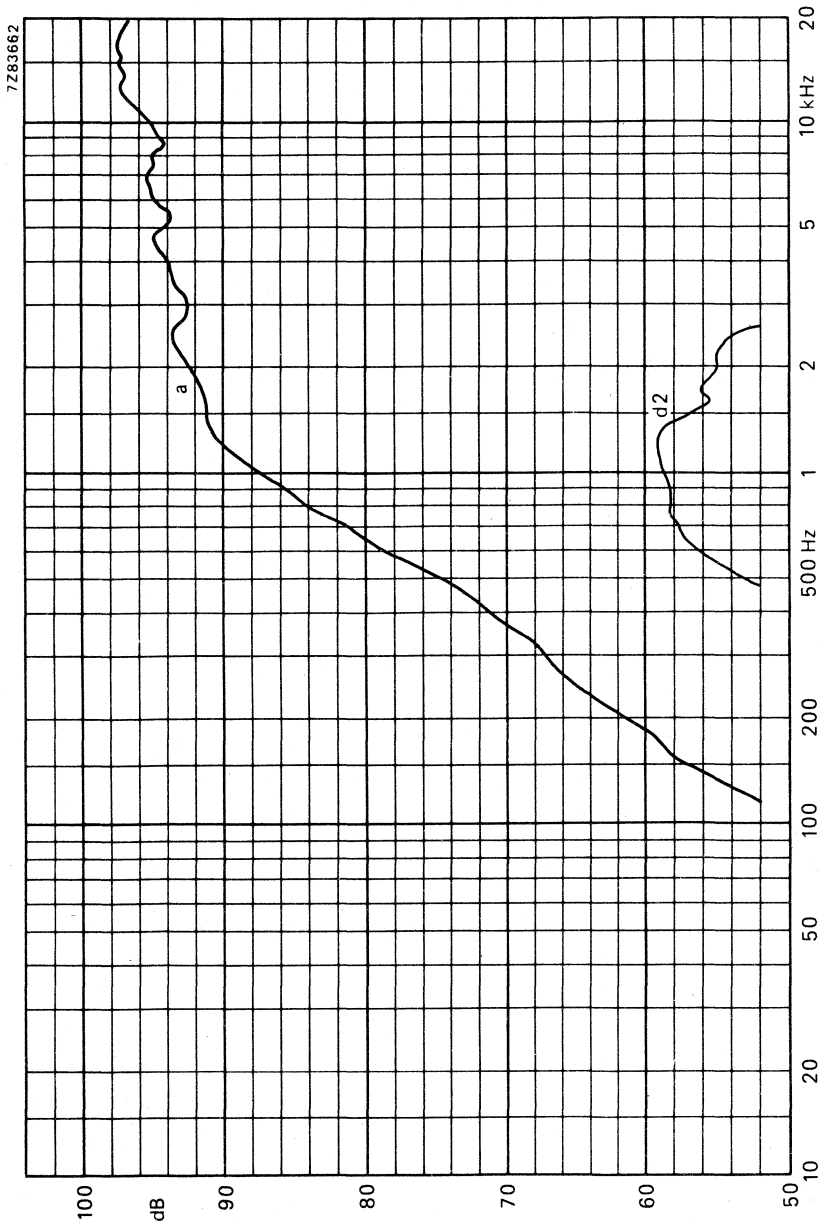

Fig. 3.



1 INCH HIGH POWER DOME TWEETER LOUDSPEAKER

APPLICATION

For the reproduction of frequencies from 2000 Hz to 22 000 Hz in multi-way high-fidelity loudspeaker systems. Minimum recommended crossover frequency 2000 Hz with 12 dB/octave slope.

TECHNICAL DATA

	version	
	T4	T8
Rated impedance	4	8 Ω
Voice coil resistance	3,4	6,3 Ω
Rated frequency range	2000 to 20 000 Hz	
Resonance frequency	1450	Hz
Power handling capacities, a/b (see Fig.1), loudspeaker unmounted,		
at 2000 Hz; C = 12 μF; L = 0,35 mH	20/4	W
at 2000 Hz; C = 8 μF; L = 0,5 mH		20/4 W
at 4000 Hz; C = 5 μF; L = 0,2 mH	50/6	W
at 4000 Hz; C = 3,2 μF; L = 0,35 mH		50/6 W
Operating power		6 W
Sweep voltage, frequency range: 500 to 20 000 Hz high pass filter:		
12 μF – 0,35 mH	3	V
5 μF – 0,2 mH		4,5 V
Energy in air gap		59 mJ
Flux density		0,9 T
Air-gap height		2,5 mm
Voice coil height	2,4	3,2 mm
Core diameter		25 mm
Magnet material		ceramic
diameter		60 mm ←
mass		0,1 kg
Mass of loudspeaker		0,25 kg

The loudspeaker has an impregnated textile dome and a diffuser integrated in the cover. Connection to the loudspeaker is by means of 2,8 mm (0,11 inch) tag connectors or by soldering.

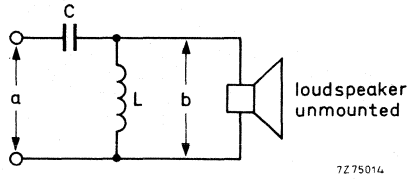

Fig.1 Measuring circuit.
 a = system power handling capacity.
 b = loudspeaker power handling capacity.

Dimensions (mm)

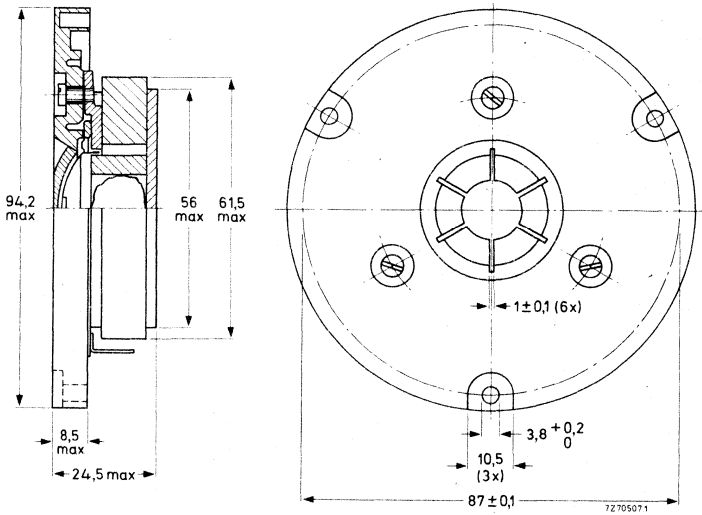

Fig.2

One tag is indicated by a red mark for in-phase connection. Baffle hole diameter 75 mm. Face of loudspeaker should lie in line with plane of baffle.

→ AVAILABLE VERSIONS

AD0141/T4, catalogue number 2422 257 33231
 AD0141/T8, catalogue number 2422 257 33232

these numbers apply to bulk packed loudspeakers, minimum packing quantity 36 per unit.

FREQUENCY RESPONSE CURVES

Curve b: Sound pressure measured in anechoic room, loudspeaker unmounted.

Curve c: 2nd and 3rd harmonic distortion, measured at the operating power of 6 W in anechoic room, loudspeaker unmounted.



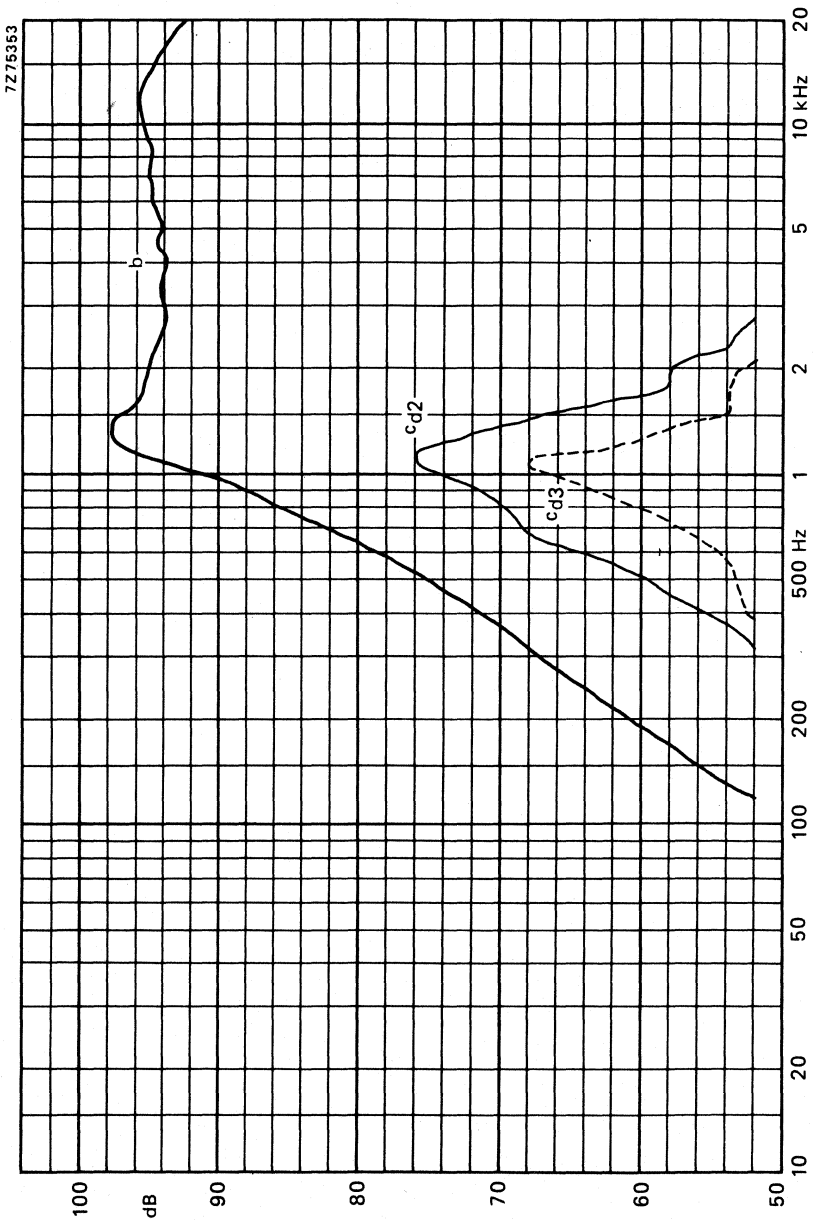

Fig.3



1 INCH HIGH POWER DOME TWEETER LOUDSPEAKERS

APPLICATION

For the reproduction of high frequencies in multi-way high-fidelity loudspeaker systems. Minimum recommended crossover frequency 1300 Hz with 6 dB/octave slope.

TECHNICAL DATA

	version			
	T4	T8	T15	
Rated impedance	4	8	15	Ω
Voice coil resistance	3,4	6,3	12,5	Ω
Rated frequency range	1300 to 20 000			Hz
Resonance frequency	950			Hz
Power handling capacities, a/b/b _{max} (see Fig. 1), loudspeaker mounted on IEC baffle,				
C = 12 μF	20/3,5/7			W
C = 6,8 μF	50/4,5/9	20/3,5/7		W
C = 4,7 μF		50/4,5/9		W
C = 3,3 μF			20/3,5/7	W
C = 2,2 μF			50/4,5/9	W
Operating power	4			W
Sweep voltage, frequency range: 500 to 20 000 Hz high pass filter:				
12 μF	3			V
6,8 μF		4,5		V
3,3 μF			5,5	V
Energy in air gap	58,5			mJ
Flux density	0,9			T
Air-gap height	2,5			mm
Voice coil height	2,4	3,2	3,4	mm
Core diameter	25			mm
Magnet material	ceramic			
diameter	61			mm
mass	0,1			kg
Mass of loudspeaker	0,26			kg

The loudspeakers have a paper dome and a diffuser integrated in the cover. They have an acoustic chamber at the back. Both types are similar except for the two aluminium rings with which the front of type AD01421/T. is embellished. Two tinned 2,8 mm (0,11 inch) tag connectors permit connection to the tweeters by plugging or soldering.

AD01420/T.
AD01421/T.

Fig. 1 Measuring circuit.
a = system power handling capacity.
b = loudspeaker power handling capacity.

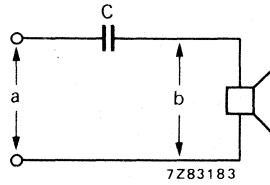

Dimensions in mm

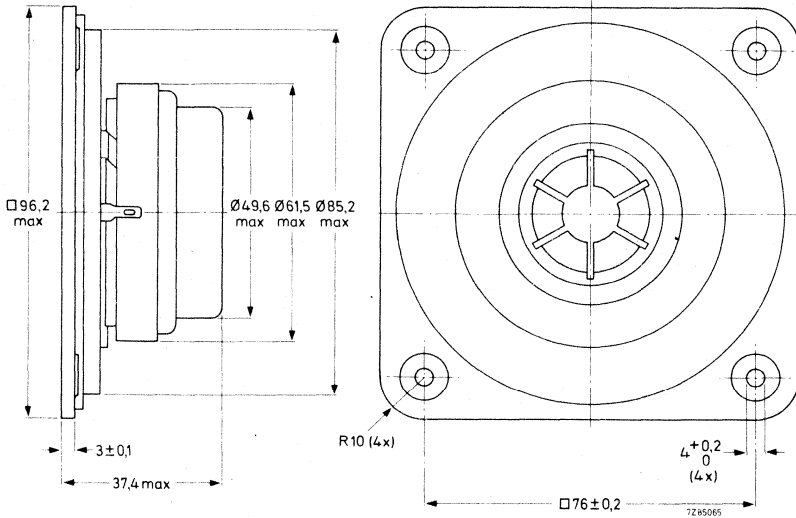

Fig. 2.

One tag is indicated by a red mark for in-phase connection. Face of loudspeaker should not lie behind plane of baffle.

→ AVAILABLE VERSIONS

AD01420/T4	catalogue number 2422 257 33131
AD01420/T8	catalogue number 2422 257 33132
AD01420/T15	catalogue number 2422 257 33133
AD01421/T4	catalogue number 2422 257 43221
AD01421/T8	catalogue number 2422 257 43222
AD01421/T15	catalogue number 2422 257 43223

these numbers apply to bulk packed loudspeakers, minimum packing quantity 36 per unit.

FREQUENCY RESPONSE CURVES (see Fig. 3)

Measured in anechoic room at the operating power. Loudspeaker mounted on IEC baffle.

Curve a: Sound pressure.

Curves d2 and d3: 2nd and 3rd harmonic distortion.

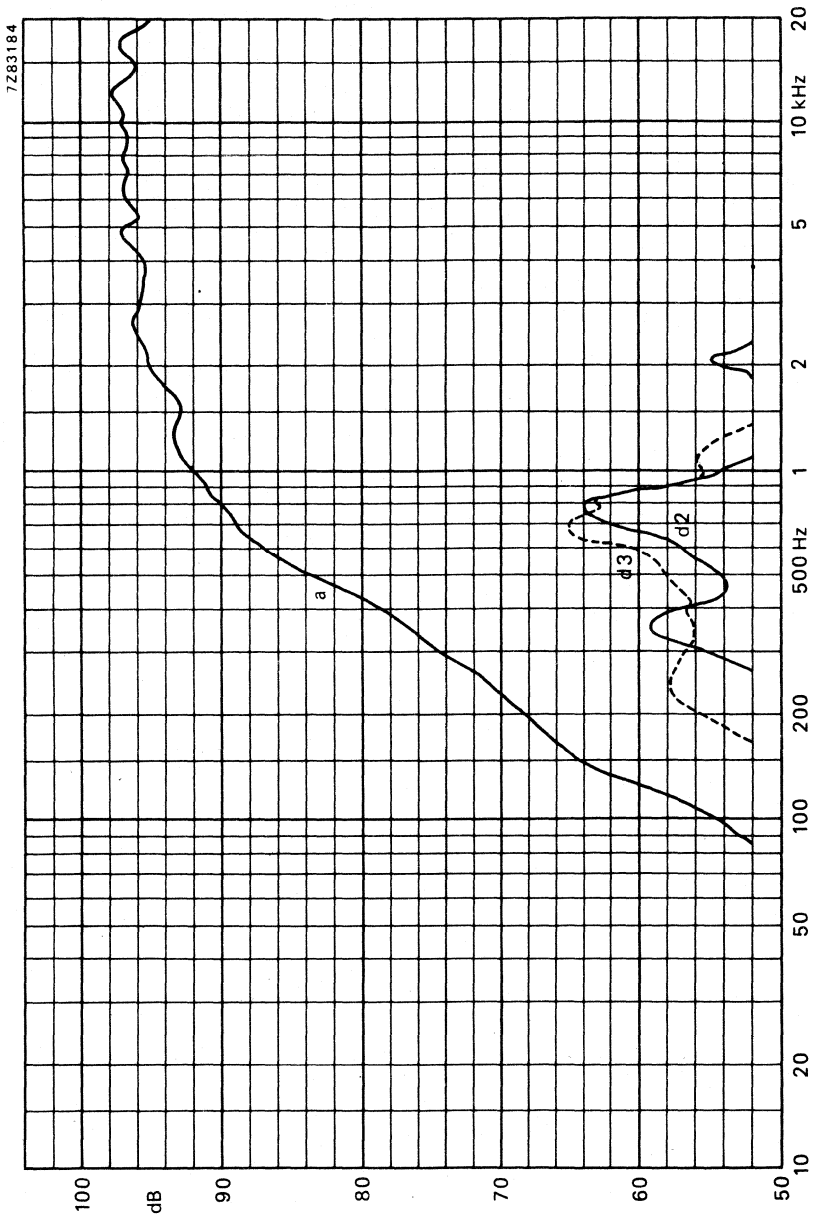

Fig. 3.



1 INCH HIGH POWER DOME TWEETER LOUDSPEAKERS

APPLICATION

For the reproduction of high frequencies in multi-way high-fidelity loudspeaker systems. Minimum recommended crossover frequency 1300 Hz with 6 dB/octave slope.

TECHNICAL DATA

	version			
	T4	T8	T15	
Rated impedance	4	8	15	Ω
Voice coil resistance	3,4	6,3	12,5	Ω
Rated frequency range	1300 to 20 000			Hz
Resonance frequency	1200			Hz
Power handling capacities, $a/b/b_{max}$ (see Fig. 1), loudspeaker mounted on IEC baffle,				
C = 12 μ F	20/3,5/7			W
C = 6,8 μ F	50/4,5/9	20/3,5/7		W
C = 4,7 μ F		50/4,5/9		W
C = 3,3 μ F			20/3,5/7	W
C = 2,2 μ F			50/4,5/9	W
Operating power	6			W
Sweep voltage, frequency range: 500 to 20 000 Hz high pass filter:				
12 μ F	3			V
6,8 μ F		4,5		V
3,3 μ F			5,5	V
Energy in air gap	58,5			mJ
Flux density	0,9			T
Air-gap height	2,5			mm
Voice coil height	2,4	3,2	3,4	mm
Core diameter	25			mm
Magnet material	ceramic			
diameter	61			mm
mass	0,1			kg
Mass of loudspeaker	0,26			kg

The loudspeakers have a textile dome and a diffuser integrated in the cover. They have an acoustic chamber at the back. Both types are similar except for the two aluminium rings with which the front of type AD01431/T. is embellished. Two tinned 2,8 mm (0,11 inch) tag connectors permit connection to the tweeters by plugging or soldering.

AD01430/T.
AD01431/T.

Fig. 1 Measuring circuit.
a = system power handling capacity.
b = loudspeaker power handling capacity.

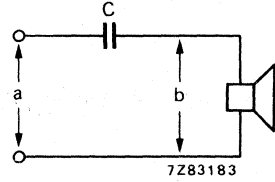

Dimensions in mm

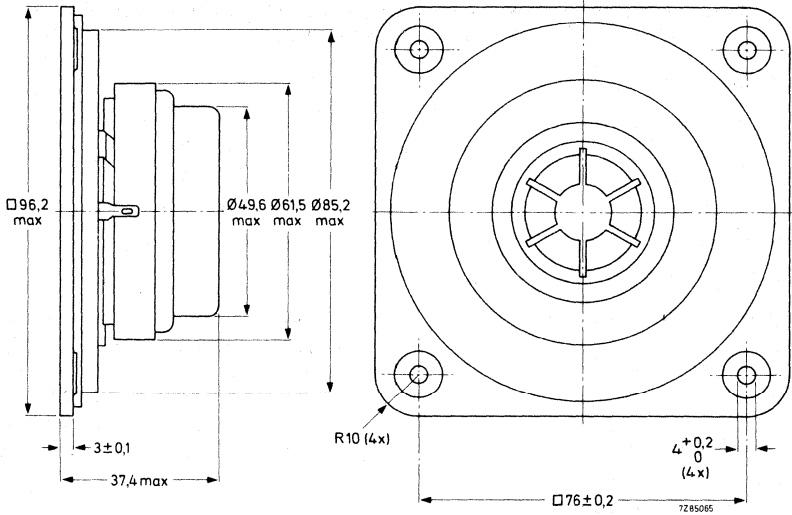

Fig. 2.

One tag is indicated by a red mark for in-phase connection. Face of loudspeaker should not lie behind plane of baffle.

→ AVAILABLE VERSIONS

AD01430/T4	catalogue number 2422 257 33135
AD01430/T8	catalogue number 2422 257 33136
AD01430/T15	catalogue number 2422 257 33137
AD01431/T4	catalogue number 2422 257 43224
AD01431/T8	catalogue number 2422 257 43225
AD01431/T15	catalogue number 2422 257 43226

these numbers apply to bulk packed loudspeakers, minimum packing quantity 36 per unit.

FREQUENCY RESPONSE CURVES (see Fig. 3)

Measured in anechoic room at the operating power. Loudspeaker mounted on IEC baffle.

Curve a: Sound pressure.

Curves d2 and d3: 2nd and 3rd harmonic distortion.

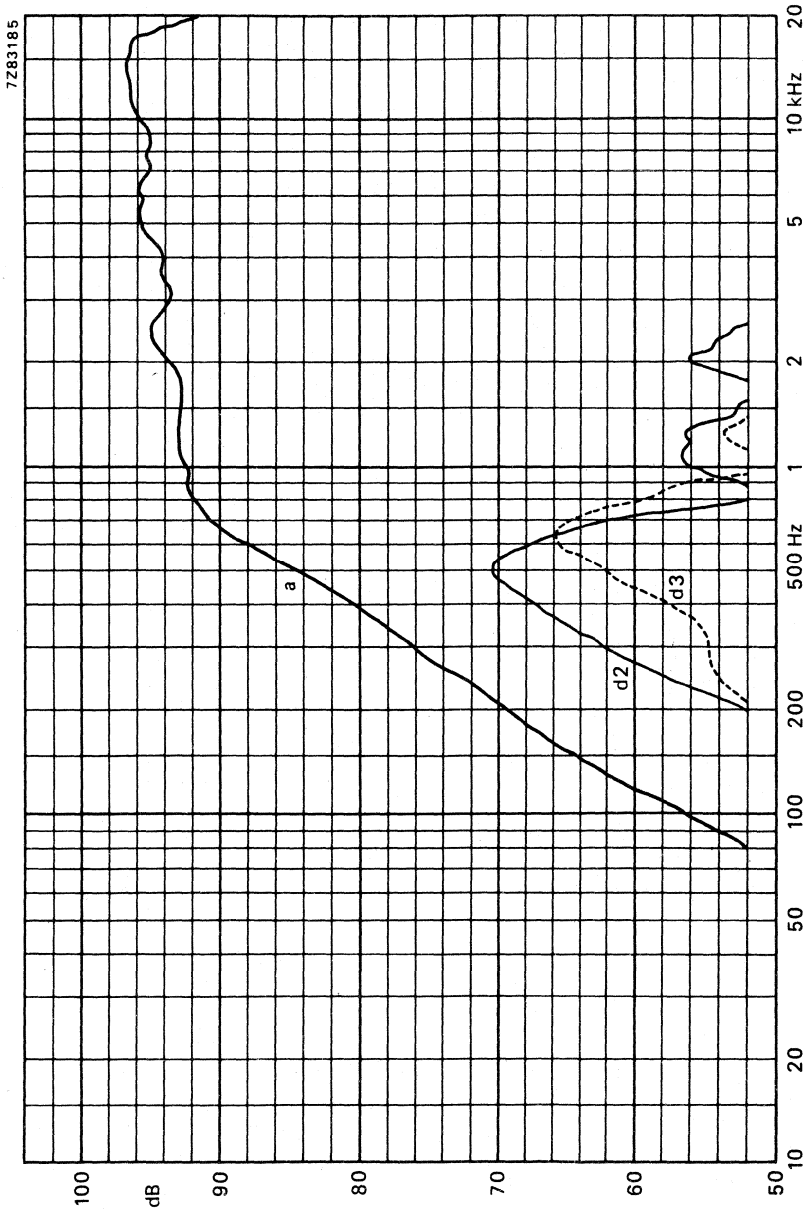

Fig. 3.



DEVELOPMENT SAMPLE DATA

This information is derived from development samples made available for evaluation. It does not necessarily imply that the device will go into regular production.

ADO147/T.

1 INCH HIGH POWER DOME TWEETER LOUDSPEAKER

APPLICATION

For the reproduction of high frequencies in multi-way high-fidelity loudspeaker systems. Minimum recommended crossover frequency 1300 Hz with 6 dB/octave slope.

TECHNICAL DATA

	versions	
	T8	T15
Rated impedance	8	15 Ω
Voice coil resistance	6,3	12,5 Ω
Rated frequency range	1300 - 20 000 Hz	
Resonance frequency	1200	Hz
Power handling capacities of system (see Fig. 1), loudspeaker mounted on IEC baffle, C = 6,8 μ F	3,5	W
C = 3,3 μ F		3,5 W
Operating power on loudspeaker	6	W
Maximum power	7	W
Sweep voltage, frequency range: 500 to 20 000 Hz		
6,8 μ F in series	4,5	V
3,3 μ F in series		5,5 V
Energy in air gap	58,5	mJ
Flux density	0,9	T
Air-gap height	2,5	mm
Voice coil height	3,2	3,4 mm
Core diameter	25	mm
Magnet material	ceramic	
diameter	60	mm
mass	0,1	kg
Mass of loudspeaker	0,25	kg

The loudspeaker has a textile dome and a diffuser integrated in the cover. It has an acoustic chamber at the back. Two tinned 2,8 mm (0,11 inch) tag connectors permit connection to the tweeter by plugging or soldering.

Fig. 1 Measuring circuit.
 a = system power handling capacity.
 b = loudspeaker power handling capacity;

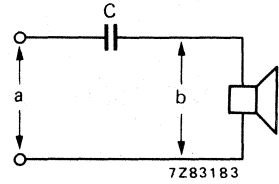

Dimensions in mm

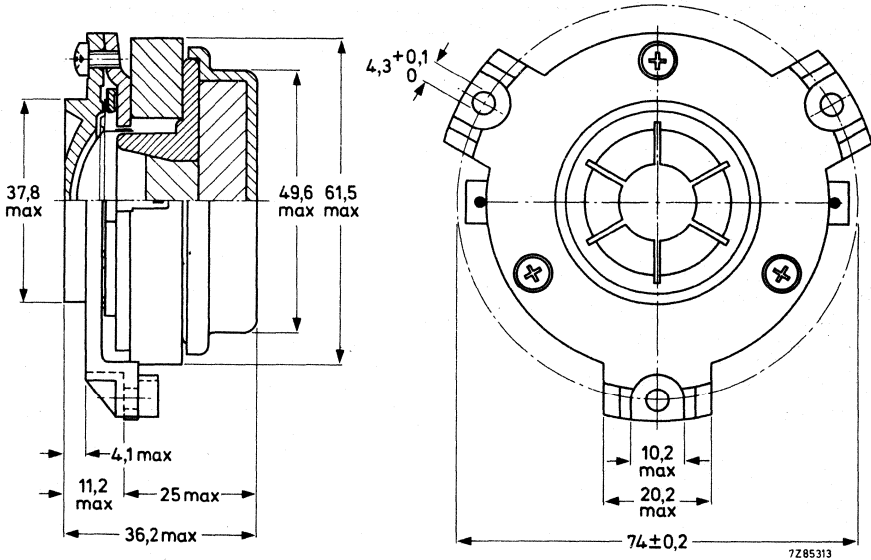

Fig. 2.

One tag is indicated by a red mark for in-phase connection. Face of loudspeaker should not lie behind plane of baffle.

AVAILABLE VERSIONS

AD0147/T4	catalogue number 2422 257 43025
AD0147/T8	catalogue number 2422 257 43026
AD0147/T15	catalogue number 2422 257 43027

these numbers apply to bulk packed loudspeakers, minimum packing quantity 12 per unit.

FREQUENCY RESPONSE CURVES (see Fig. 3)

Measured in anechoic room at the operating power. Loudspeaker mounted on IEC baffle.

Curve a: Sound pressure.

Curves d2 and d3: 2nd and 3rd harmonic distortion.

DEVELOPMENT SAMPLE DATA

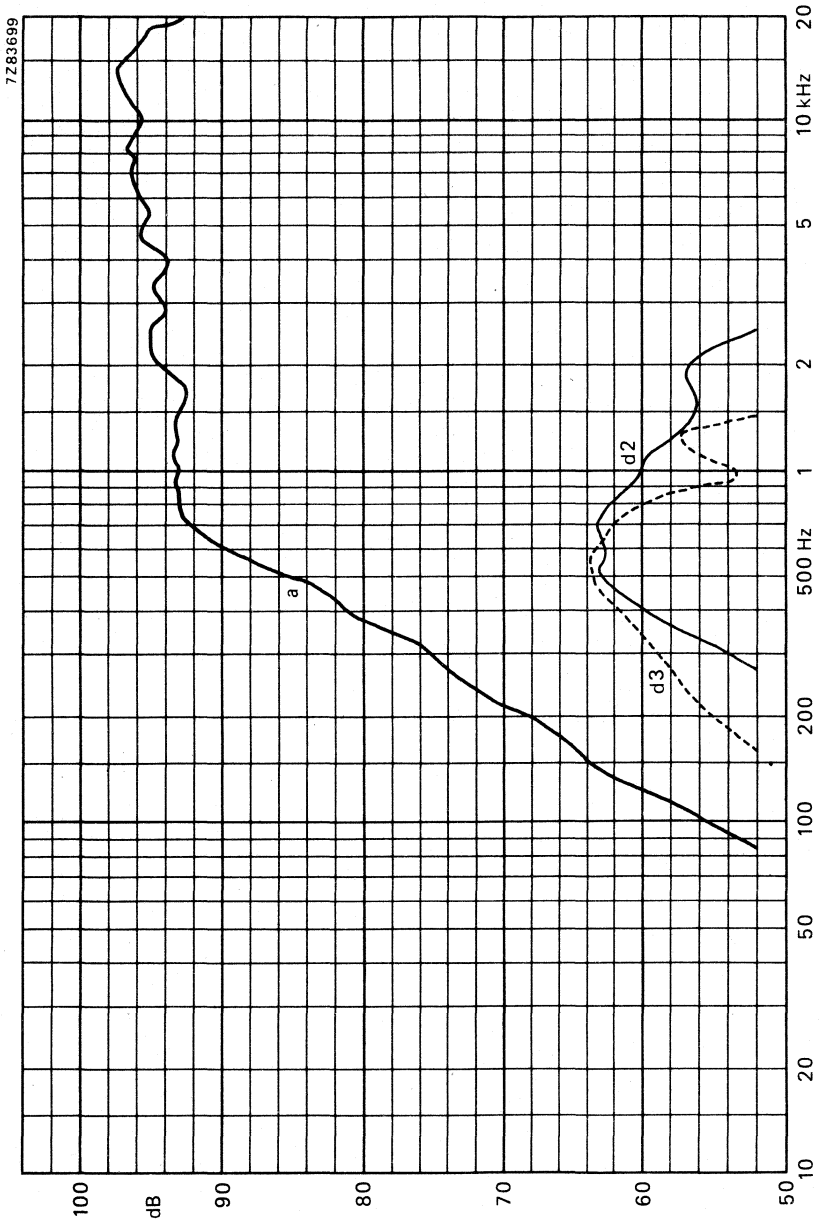

Fig. 3.



1 INCH HIGH POWER DOME TWEETER LOUDSPEAKERS

APPLICATION

For high power, high-fidelity loudspeaker systems. The tweeters have a very wide radiating pattern due to their flat front and forward dome.

TECHNICAL DATA

	version		
	T4	T8	T15
Rated impedance	4	8	15 Ω
Voice coil resistance	3,4	6,3	12,5 Ω
Rated frequency range	2000 to 22 000		Hz ←
Resonance frequency	1250		Hz
Power handling capacities, a/b (see Fig. 1), loudspeaker unmounted,			
at 2000 Hz; C = 12 μ F; L = 0,35 mH	20/4		W
at 2000 Hz; C = 8 μ F; L = 0,5 mH		20/4	W
at 2000 Hz; C = 3,3 μ F; L = 1 mH			20/4 W
at 4000 Hz; C = 5 μ F; L = 0,2 mH	50/6		W
at 4000 Hz; C = 3,2 μ F; L = 0,35 mH		50/6	W
at 4000 Hz; C = 1,5 μ F; L = 0,8 mH			50/6 W
Operating power		5	W
Sweep voltage, frequency range: 500 to 20 000 Hz high pass filter:			
12 μ F – 0,35 mH	5		V ←
8 μ F – 0,5 mH		4,5	V
3,3 μ F – 1 mH			5,5 V
Energy in air gap		75	mJ
Flux density		1,2	T
Air-gap height		2,5	mm
Voice coil height	2,4	3,2	3,4 mm
Core diameter		25	mm
Magnet material		ceramic	
diameter		72	mm
mass		0,24	kg
Mass of loudspeaker		0,5	kg

The loudspeakers have an impregnated textile dome. They are provided with an acoustic sealing strip at the back of the square flange. Type AD 01605/T is a 'de luxe' version with two aluminium rings at the front. Connection to the tweeters by means of tag connectors or by soldering.

Fig. 1 Measuring circuit.
a = system power handling capacity.
b = loudspeaker power handling capacity.

Dimensions in mm

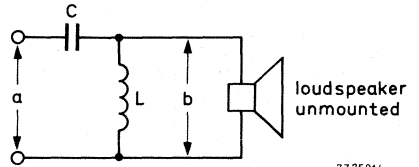

72 75014

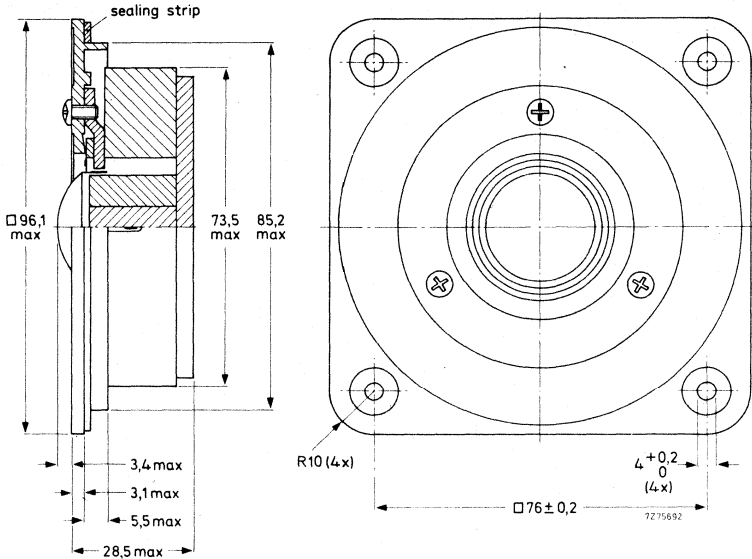

Fig. 2.

One tag is indicated by a red mark for in-phase connection. Face of loudspeaker should not lie behind plane of baffle.

→ AVAILABLE VERSIONS

- AD01600/T4, catalogue number 2422 257 33521
- AD01600/T8, catalogue number 2422 257 33522
- AD01600/T15, catalogue number 2422 257 33523
- AD01605/T4, catalogue number 2422 257 33531
- AD01605/T8, catalogue number 2422 257 33532
- AD01605/T15, catalogue number 2422 257 33533

these numbers apply to bulk packed loudspeakers, minimum packing quantity 30 per unit.

FREQUENCY RESPONSE CURVES (see Fig. 3)

Curve a: Sound pressure measured in anechoic room, loudspeaker unmounted.

Curves d2 and d3: 2nd and 3rd harmonic distortion, measured at the operating power of 5 W in anechoic room, loudspeaker front mounted on IEC baffle.

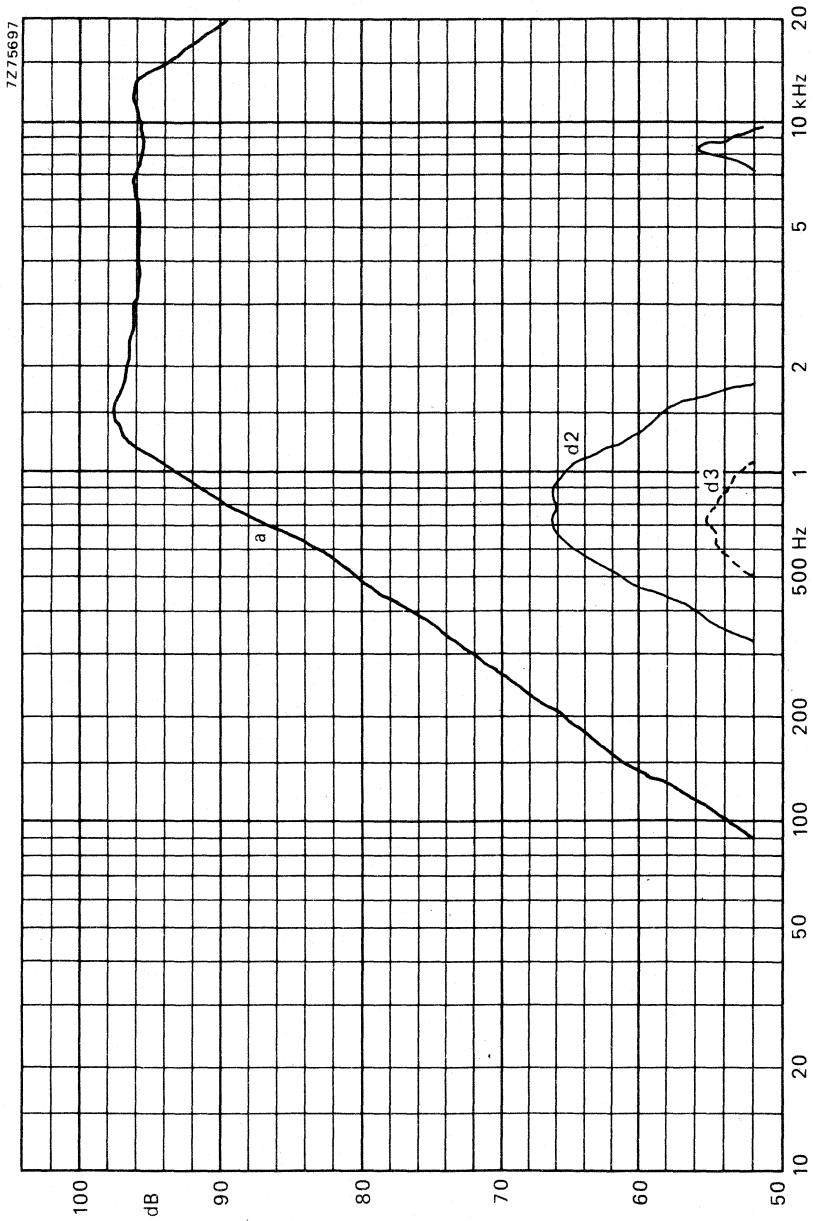

Fig. 3.



1 INCH HIGH POWER DOME TWEETER LOUDSPEAKERS

APPLICATION

For high power, high-fidelity loudspeaker systems. The tweeter has a wide radiating pattern due to its nearly flat conical front.

TECHNICAL DATA

	version		
	T4	T8	T15
Rated impedance	4	8	15 Ω
Voice coil resistance	3,4	6,3	12,5 Ω
Rated frequency range	2000 to 22 000		Hz ←
Resonance frequency	1250		Hz
Power handling capacities, a/b (see Fig. 1), loudspeaker unmounted,			
at 2000 Hz; C = 12 μ F; L = 0,35 mH	20/4		W
at 2000 Hz; C = 8 μ F; L = 0,5 mH		20/4	W
at 2000 Hz; C = 3,3 μ F; L = 1 mH			20/4 W
at 4000 Hz; C = 5 μ F; L = 0,2 mH	50/6		W
at 4000 Hz; C = 3,2 μ F; L = 0,35 mH		50/6	W
at 4000 Hz; C = 1,5 μ F; L = 0,8 mH			50/6 W
Operating power		4	W
Sweep voltage,			
frequency range: 500 to 20 000 Hz			
high pass filter:			
12 μ F – 0,35 mH	3,2		V
8 μ F – 0,5 mH		4,5	V
3,3 μ F – 1 mH			5,5 V
Energy in air gap		75	mJ
Flux density		1,2	T
Air-gap height		2,5	mm
Voice coil height	2,4	3,2	mm
Core diameter		25	mm
Magnet material		ceramic	
diameter		72	mm
mass		0,24	kg
Mass of loudspeaker		0,5	kg



The loudspeaker has an impregnated textile dome. It is provided with an acoustic sealing strip at the back of the square flange. Connection to the tweeter by means of tag connectors or by soldering.

Fig. 1 Measuring circuit.
 a = system power handling capacity.
 b = loudspeaker power handling capacity.

Dimensions (mm)

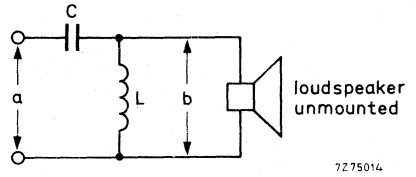

7275014

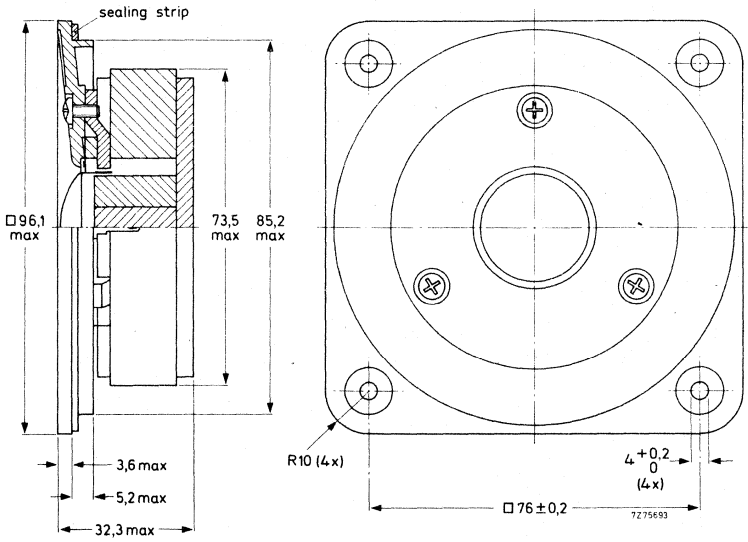

Fig. 2.

One tag is indicated by a red mark for in-phase connection. Face of loudspeaker should not lie behind plane of baffle.

→ AVAILABLE VERSIONS

- AD01610/T4, catalogue number 2422 257 33621
- AD01610/T8, catalogue number 2422 257 33622
- AD01610/T15, catalogue number 2422 257 33623

these numbers apply to bulk packed loudspeakers, minimum packing quantity 30 per unit.

FREQUENCY RESPONSE CURVES (see Fig. 3)

Curve a: Sound pressure measured in anechoic room, loudspeaker unmounted.
 Curves d2 and d3: 2nd and 3rd harmonic distortion, measured at the operating power of 4 W in anechoic room, loudspeaker front mounted on IEC baffle.

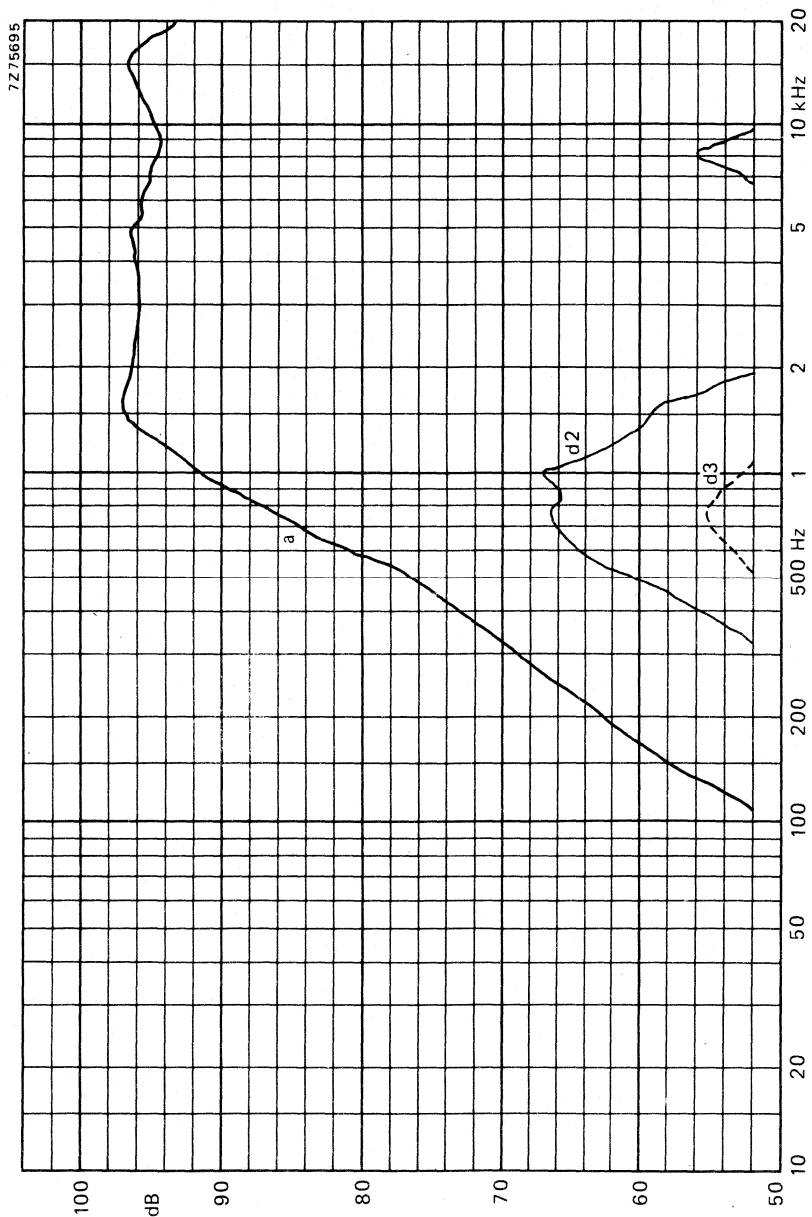

Fig. 3.



1 INCH HIGH POWER DOME TWEETER LOUDSPEAKERS

APPLICATION

For use in direct and indirect radiating systems for reproduction of audio frequencies from 2000 Hz to 22 000 Hz with very low distortion in multi-way high fidelity loudspeaker systems in accordance with DIN 45500. Minimum recommended cross-over frequency 1600 Hz. The loudspeaker has a very high sensitivity.

TECHNICAL DATA

	version		
	T4	T8	T15
Rated impedance	4	8	15 Ω
Voice coil resistance	3,4	6,3	12,5 Ω
Rated frequency range	2000 to 22 000 Hz		
Resonance frequency	1000		Hz
Power handling capacities a/b (see Fig. 1)			
at 2000 Hz C = 12 μ F L = 0,35 mH	20/4		W
C = 8 μ F L = 0,5 mH		20/4	W
C = 3,3 μ F L = 1 mH			20/4 W
at 4000 Hz C = 3,2 μ F L = 0,35 mH	50/6	50/6	W
C = 1,5 μ F L = 0,8 mH			50/6 W
Operating power		2	W
Sweep voltage			
frequency range: 500–20 000 Hz			
high pass filter: 8 μ F–0,5 mH	3,2	4,5	5,5 V
Energy in air gap		75	mJ
Flux density		1,2	T
Air-gap height		2,5	mm
Voice coil height	2,4	2,4	3,4 mm
Core diameter		25	mm
Magnet material	ceramic		
diameter		72	mm
mass		0,24	kg
Mass of loudspeaker		0,5	kg

The loudspeaker has a polycarbonate dome and a diffusor integrated in the cover.

Connection to the loudspeaker by means of 2,8 mm (0,11 inch) tag connectors or by soldering.

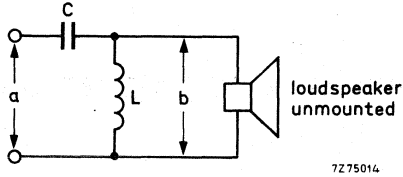

Fig. 1 Measuring circuit.
 a = system power handling capacity.
 b = loudspeaker power handling capacity.

Dimensions in mm

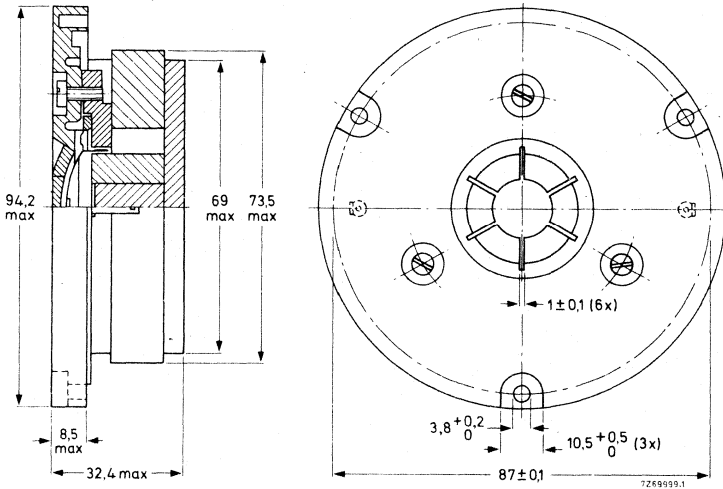

Fig. 2.

One tag is indicated by a red mark for in-phase connection.
 Face of loudspeaker should not lie behind plane of baffle.

→ AVAILABLE VERSIONS

- AD0162/T4, catalogue number 2422 257 33331
- AD0162/T8, catalogue number 2422 257 33332
- AD0162/T15, catalogue number 2422 257 33333

these numbers apply to bulk packed loudspeakers, minimum packing quantity 30 per unit.

FREQUENCY RESPONSE CURVES (see Fig. 3)

- Curve a: Sound pressure measured in anechoic room, loudspeaker unmounted.
Above 1000 Hz, over the width of one octave, the sound pressure may be a maximum of 2 dB lower than indicated.
- Curve d: 2nd and 3rd harmonic distortion, measured at the operating power of 2 W in anechoic room, loudspeaker unmounted.



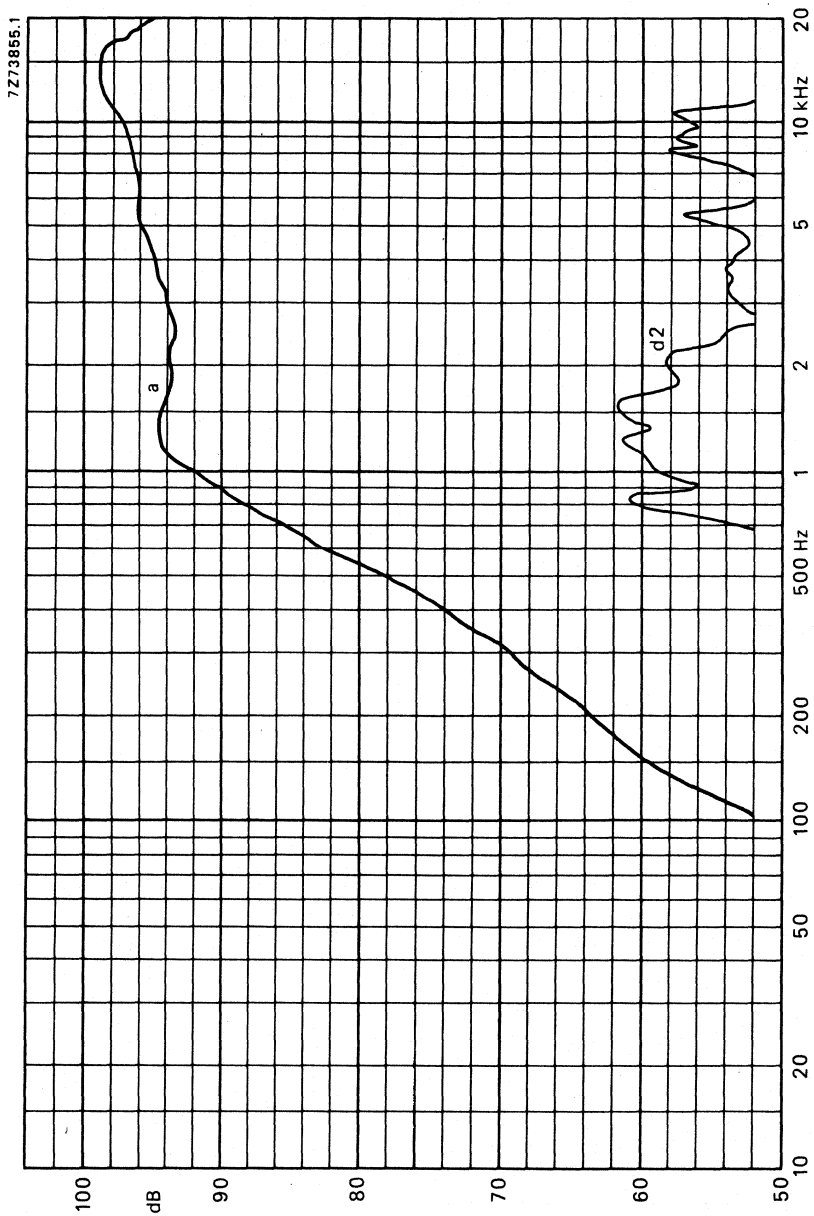

Fig. 3.

DEVELOPMENT SAMPLE DATA

This information is derived from development samples made available for evaluation. It does not necessarily imply that the device will go into regular production.

AD01624/T.

1 INCH FERROFLUID DOME TWEETER LOUDSPEAKER

APPLICATION

For the reproduction of high frequencies in multi-way high-fidelity loudspeaker systems. Minimum recommended crossover frequency 2000 Hz with 12 dB/octave slope.

TECHNICAL DATA

	version	
	T4	T8
Rated impedance	4	8 Ω
Voice coil resistance	3,4	6,3 Ω
Rated frequency range	2000 to 22 000 Hz	
Resonance frequency	1600 Hz	
Power handling capacities, a/b (see Fig. 1), loudspeaker unmounted		
C = 12 μ F; L = 0,35 mH	20/4	W
C = 5 μ F; L = 0,2 mH	50/6	W
C = 8 μ F; L = 0,5 mH		20/4 W
C = 3,2 μ F; L = 0,35 mH		50/6 W
Operating power	2	W
Sweep voltage, frequency range: 500 to 20 000 Hz, high pass filter:		
12 μ F — 0,35 mH	3	V
8 μ F — 0,5 mH		4,5 V
Energy in air gap	75	mJ
Flux density	1,8	1,2 T
Air-gap height	2,5	mm
Voice coil height	2,4	3,2 mm
Core diameter	25	mm
Magnet material	ceramic	
diameter	72	mm
mass	0,24	kg
Mass of loudspeaker	0,5	kg

The loudspeaker has a polycarbonate dome and a diffuser integrated in the cover. Two tinned 2,8 mm (0,11 inch) tag connectors permit connection to the tweeter by plugging or soldering.



Fig. 1 Measuring circuit.

a = system power handling capacity.
 b = loudspeaker power handling capacity.

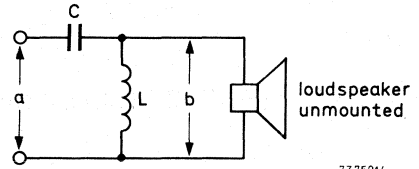

7275014

Dimensions in mm

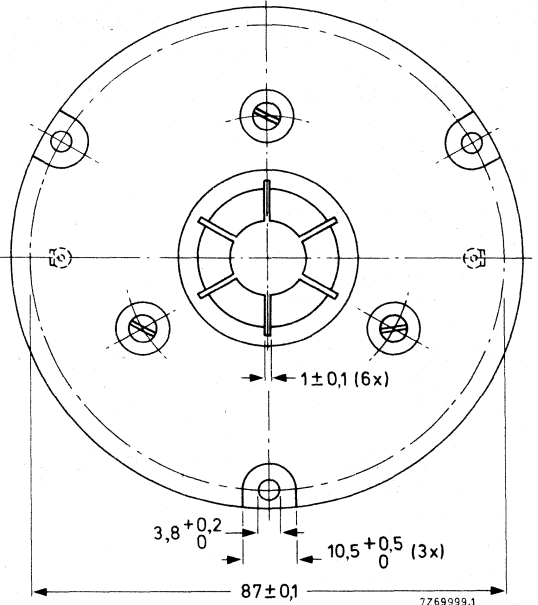
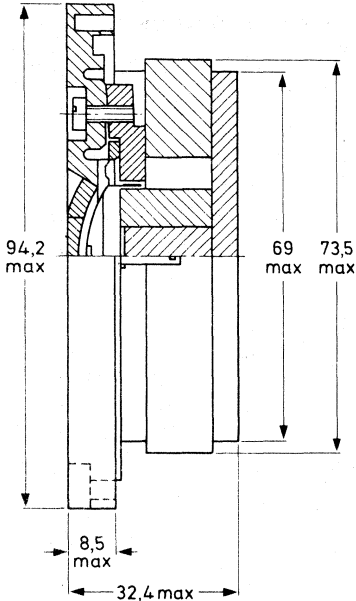

7276999.1

Fig. 2.

One tag is indicated by a red mark for in-phase connection. Face of loudspeaker should not lie behind plane of baffle.

AVAILABLE VERSIONS

AD01624/T4, catalogue number 2422 257 33335
 AD01624/T8, catalogue number 2422 257 33336

these numbers apply to bulk packed loudspeakers, minimum packing quantity 30 per unit.

FREQUENCY RESPONSE CURVES (See Fig. 3)

Measured in anechoic room at the operating power. Loudspeaker mounted on IEC baffle.

Curve a: Sound pressure.

Curve d2: 2nd harmonic distortion.

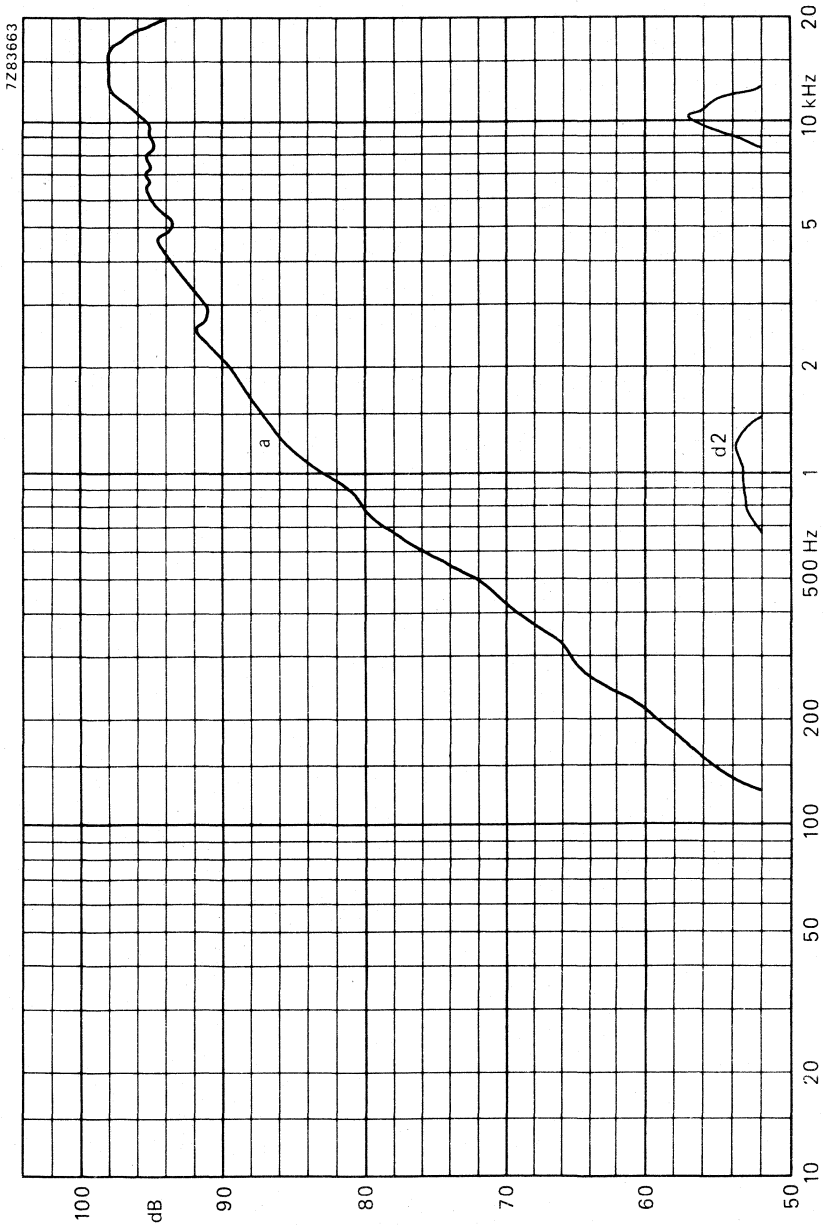

Fig. 3.



1 INCH HIGH POWER DOME TWEETER LOUDSPEAKER

APPLICATION

For use in direct and indirect radiating systems for reproduction of frequencies from 2000 Hz to 22 000 Hz with very low distortion in multi-way high-fidelity loudspeaker systems in accordance with DIN 45500. Minimum recommended crossover frequency 2000 Hz. The loudspeaker has a very high sensitivity.

TECHNICAL DATA

	version	
	T8	T15
Rated impedance	8	15 Ω
Voice coil resistance	6,3	12,5 Ω
Rated frequency range	2000 to 22 000 Hz	
Resonance frequency	1300	Hz
Power handling capacities, a/b (see Fig.1), loudspeaker unmounted,		
at 2000 Hz; C = 8 μ F; L = 0,5 mH	20/4	W
at 2000 Hz; C = 3,3 μ F; L = 1 mH		20/4 W
at 4000 Hz; C = 3,2 μ F; L = 0,35 mH	50/6	W
at 4000 Hz; C = 1,5 μ F; L = 0,8 mH		50/6 W
Operating power		3 W ←
Sweep voltage, frequency range: 500 to 20 000 Hz high pass filter: 8 μ F – 0,5 mH	4,5	V
3,3 μ F – 1 mH		5,5 V
Energy in air gap		75 mJ
Flux density		1,2 T
Air-gap height		2,5 mm
Voice coil height	2,4	3,4 mm
Core diameter		25 mm
Magnet material		ceramic
diameter		72 mm
mass		0,24 kg
Mass of loudspeaker		0,5 kg

The loudspeaker has an impregnated textile dome and a diffuser integrated in the cover. Connection to the loudspeaker by means of 2,8 mm (0,11 inch) tag connectors or by soldering.

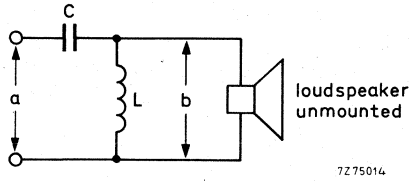

Fig.1 Measuring circuit.
 a = system power handling capacity.
 b = loudspeaker power handling capacity.

Dimensions (mm)

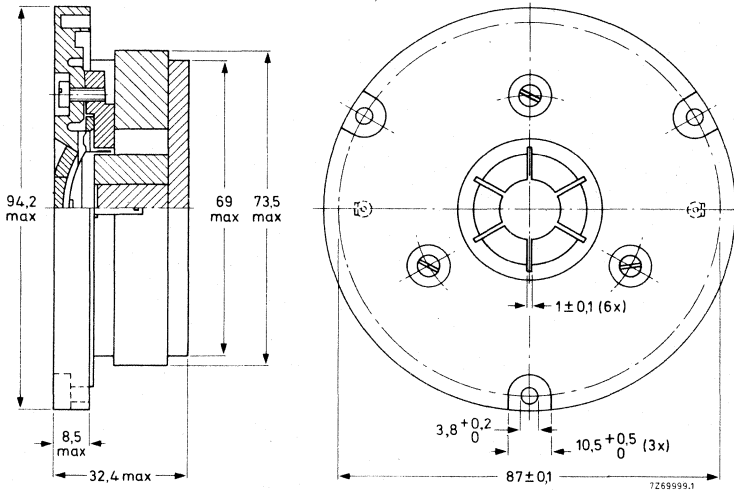

Fig.2

One tag is indicated by a red mark for in-phase connection. Face of loudspeaker should not lie behind plane of baffle.

→ AVAILABLE VERSIONS

- AD0163/T8, catalogue number 2422 257 33422
- AD0163/T15, catalogue number 2422 257 33423

} these numbers apply to bulk packed loudspeakers, minimum packing quantity 30 per unit.

FREQUENCY RESPONSE CURVES (see Fig. 3)

Curve a: Sound pressure measured in anechoic room, loudspeaker unmounted.

Curve d2: 2nd harmonic distortion, measured at the operating power of 2 W in anechoic room, loudspeaker unmounted. ←



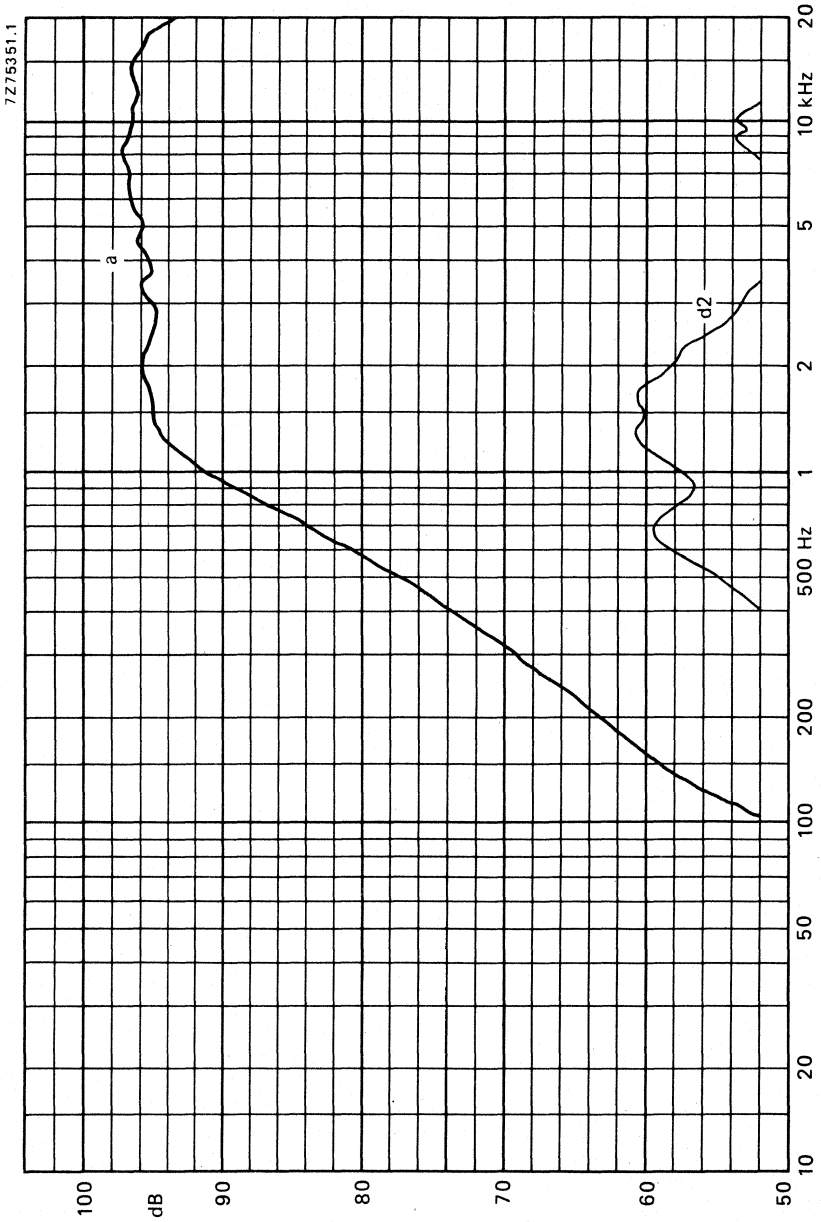

Fig. 3.



1 INCH HIGH POWER DOME TWEETER LOUDSPEAKERS

APPLICATION

For use in direct and indirect radiating systems for reproduction of frequencies from 2000 Hz to 22 000 Hz with very low distortion in multi-way high-fidelity loudspeaker systems in accordance with DIN 45 500. Minimum recommended crossover frequency 2000 Hz. The loudspeaker has a very high sensitivity.

TECHNICAL DATA

	version	
	T8	T15
Rated impedance	8	15 Ω
Voice coil resistance	6,3	12,5 Ω
Rated frequency range	2000 to 22 000 Hz	
Resonance frequency	1300 Hz	
Power handling capacities, a/b (see Fig. 1), loudspeaker unmounted,		
at 2000 Hz; C = 8 μ F; L = 0,5 mH	20/4	W
at 2000 Hz; C = 3,3 μ F; L = 1 mH		20/4 W
at 4000 Hz; C = 3,2 μ F; L = 0,35 mH	50/6	W
at 4000 Hz; C = 1,5 μ F; L = 0,8 mH		50/6 W
Operating power		3 W
Sweep voltage, frequency range: 500 to 20 000 Hz high pass filter:		
8 μ F - 0,5 mH	4,5	V
3,3 μ F - 1 mH		5,5 V
Energy in air gap		75 mJ
Flux density		1,2 T
Air-gap height		2,5 mm
Voice coil height	2,4	3,4 mm
Core diameter		25 mm
Magnet material	ceramic	
diameter		72 mm
mass		0,24 kg
Mass of loudspeaker		0,5 kg

The loudspeakers have an impregnated textile dome and a diffuser integrated in the cover. Both types have a square flange and are similar except for the two aluminium rings with which the front of type AD01631/T is embellished. Connection to the tweeters by means of tag connectors or by soldering.

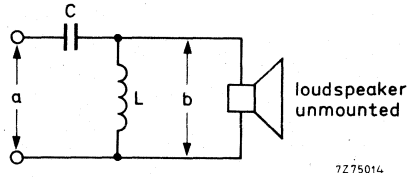

Fig. 1 Measuring circuit.
a = system power handling capacity.
b = loudspeaker power handling capacity.

Dimensions (mm)

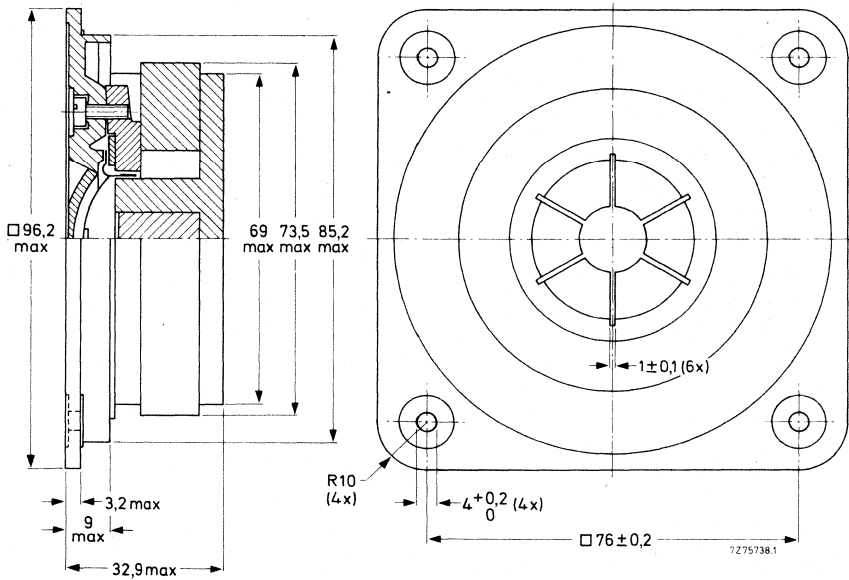

Fig. 2.

One tag is indicated by a red mark for in phase connection. Face of loudspeaker should not lie behind plane of baffle.

→ AVAILABLE VERSIONS

AD01630/T8, catalogue number 2422 257 33822

AD01630/T15, catalogue number 2422 257 33823

AD01631/T8, catalogue number 2422 257 33832

AD01631/T15, catalogue number 2422 257 33833

these numbers apply to bulk
packed loudspeakers, minimum
packing quantity 30 per unit.

FREQUENCY RESPONSE CURVES (see Fig. 3)

Curve a: Sound pressure measured in anechoic room, loudspeaker unmounted.

Curve d2: 2nd harmonic distortion, measured at the operating power of 3 W in anechoic room, loudspeaker unmounted.



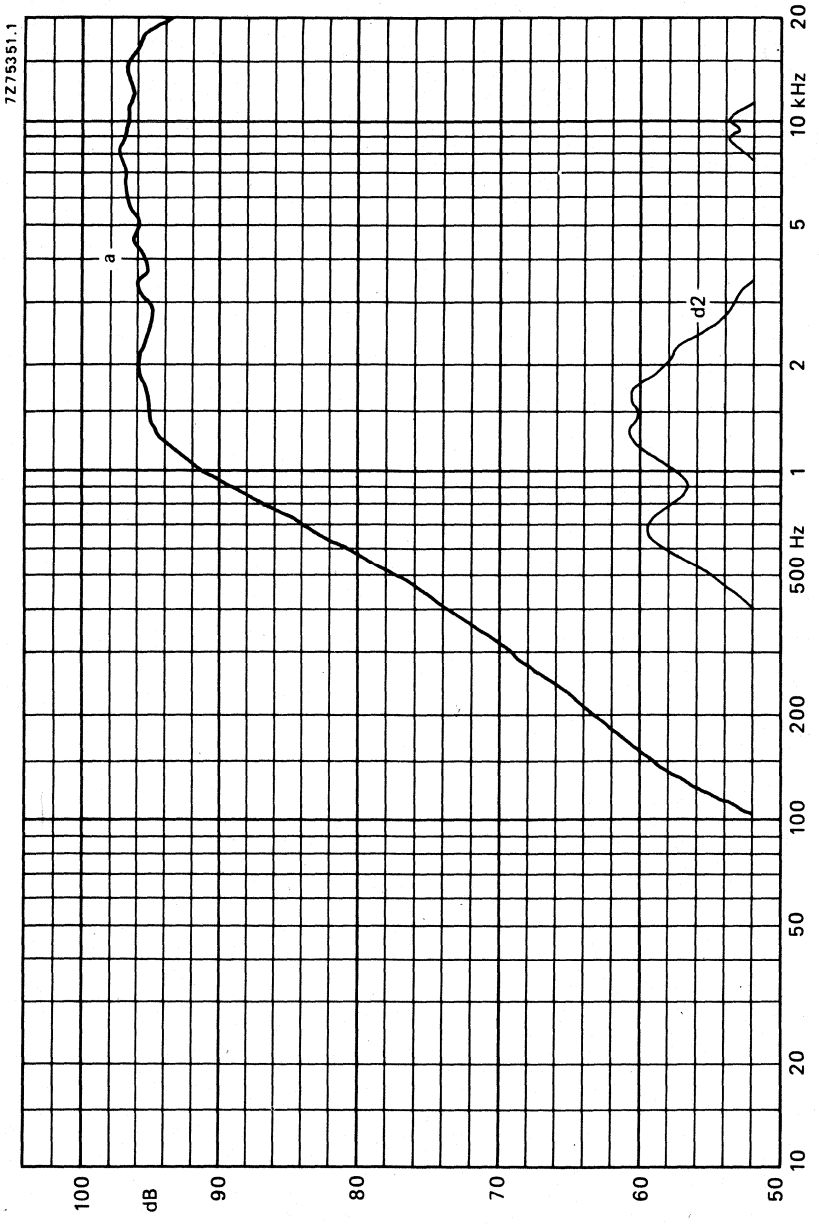

Fig. 3.



1 INCH HIGH POWER DOME TWEETER LOUDSPEAKERS

APPLICATION

For use in direct and indirect radiating systems for reproduction of frequencies from 2000 Hz to 22 000 Hz with very low distortion in multi-way high-fidelity loudspeaker systems in accordance with DIN 45 500. Minimum recommended crossover frequency 2000 Hz. The loudspeaker has a very high sensitivity.

TECHNICAL DATA

	version	
	T8	T15
Rated impedance	8	15 Ω
Voice coil resistance	6,3	12,5 Ω
Rated frequency range	2000 to 22 000 Hz	
Resonance frequency	1200	Hz ←
Power handling capacities, a/b (see Fig. 1), loudspeaker unmounted,		
at 2000 Hz; C = 8 μ F; L = 0,5 mH	50/6	W
at 2000 Hz; C = 3,3 μ F; L = 1 mH		50/6 W
at 4000 Hz; C = 3,2 μ F; L = 0,35 mH	70/8	W
at 4000 Hz; C = 1,5 μ F; L = 0,8 mH		70/8 W
Operating power		2 W
Sweep voltage, frequency range: 500 to 20 000 Hz high pass filter:		
8 μ F – 0,5 mH	4,5	V
3,3 μ F – 1 mH		5,5 V
Energy in air gap		75 mJ
Flux density		1,2 T
Air-gap height		2,5 mm
Voice coil height	2,4	3,4 mm
Core diameter		25 mm
Magnet material	ceramic	
diameter		72 mm
mass		0,24 kg
Mass of loudspeaker		0,5 kg

The loudspeakers have a paper dome and a diffuser integrated in the cover. Both types have a square flange and are similar except for the two aluminium rings with which the front of type AD01633/T. is embellished. Two tinned 2,8 mm (0,11 inch) tag connectors permit connection to the tweeters by plugging or soldering.

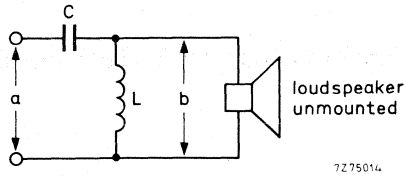

Fig. 1 Measuring circuit.
a = system power handling capacity.
b = loudspeaker power handling capacity.

Dimensions in mm

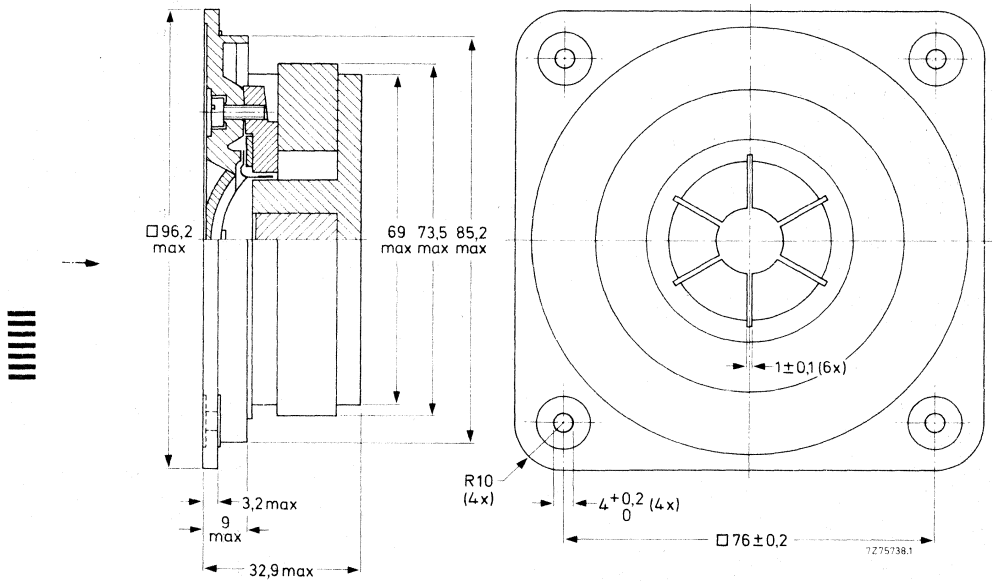

Fig. 2.

One tag is indicated by a red mark for in phase connection. Face of loudspeaker should not lie behind plane of baffle.

AVAILABLE VERSIONS

AD01632/T8, catalogue number 2422 257 33826
AD01632/T15, catalogue number 2422 257 33827

AD01633/T8, catalogue number 2422 257 33836
AD01633/T15, catalogue number 2422 257 33837

} these numbers apply to bulk
packed loudspeakers, minimum
packing quantity 30 per unit.

FREQUENCY RESPONSE CURVES (see Fig. 3)

Curve a: Sound pressure measured in anechoic room, loudspeaker unmounted.

Curve d2: 2nd harmonic distortion, measured at the operating power of 2 W in anechoic room, loudspeaker unmounted.



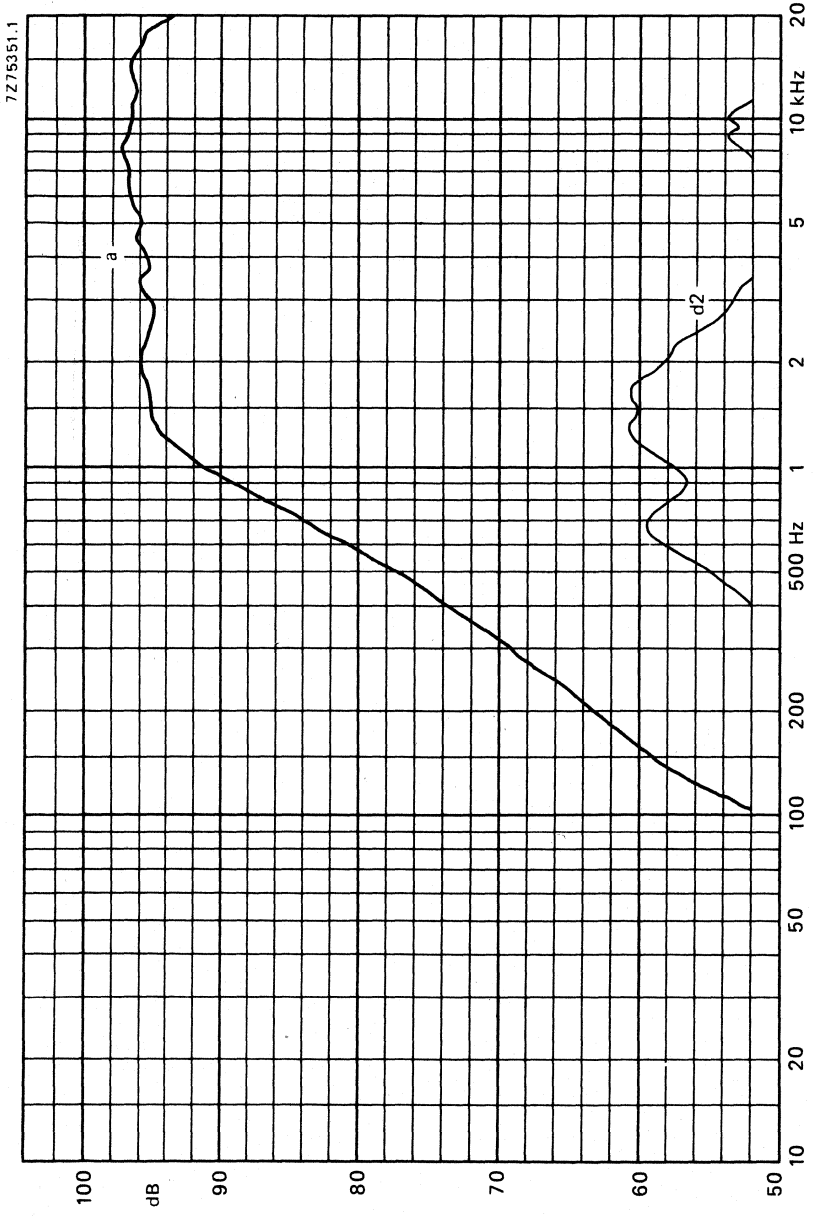

Fig. 3.

DEVELOPMENT SAMPLE DATA

This information is derived from development samples made available for evaluation. It does not necessarily imply that the device will go into regular production.

AD01634/T.

1 INCH FERROFLUID DOME TWEETER LOUDSPEAKER

APPLICATION

For the reproduction of high frequencies in multi-way high-fidelity loudspeaker systems. Minimum recommended crossover frequency 2200 Hz with 12 dB/octave slope.

TECHNICAL DATA

	version	
	T4	T8
Rated impedance	4	8 Ω
Voice coil resistance	3,4	6,3 Ω
Rated frequency range	2200 to 22 000 Hz	
Resonance frequency	2000 Hz	
Power handling capacities, a/b (see Fig. 1), loudspeaker unmounted		
C = 12 μ F; L = 0,35 mH	20/4	W
C = 5 μ F; L = 0,2 mH	50/6	W
C = 8 μ F; L = 0,5 mH		20/4 W
C = 3,2 μ F; L = 0,35 mH		50/6 W
Operating power		3 W
Sweep voltage, frequency range: 500 to 20 000 Hz, high pass filter:		
12 μ F — 0,35 mH	3	V
8 μ F — 0,5 mH		4,5 V
Energy in air gap		75 mJ
Flux density	1,2	T
Air-gap height	2,5	mm
Voice coil height	2,4	3,2 mm
Core diameter		25 mm
Magnet material	ceramic	
diameter		72 mm
mass		0,24 kg
Mass of loudspeaker		0,5 kg

The loudspeaker has a textile dome and a diffuser integrated in the cover. Two tinned 2,8 mm (0,11 inch) tag connectors permit connection to the tweeter by plugging or soldering.

Fig. 1 Measuring circuit.

a = system power handling capacity.
 b = loudspeaker power handling capacity.

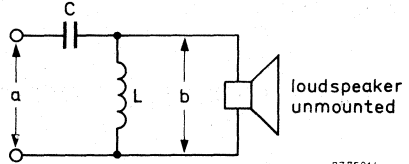

7275014

Dimensions in mm

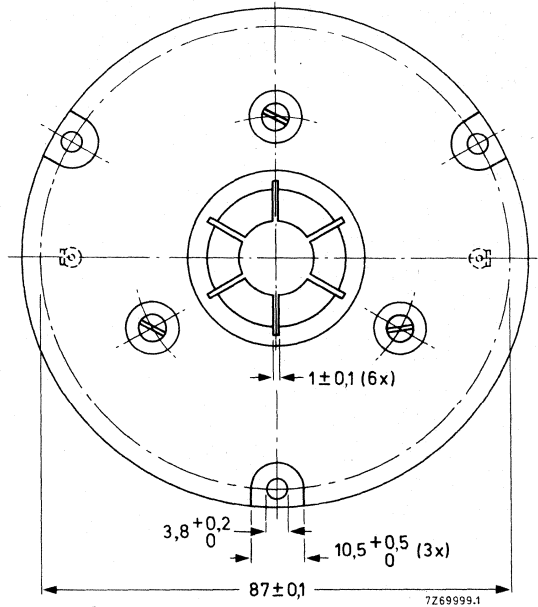
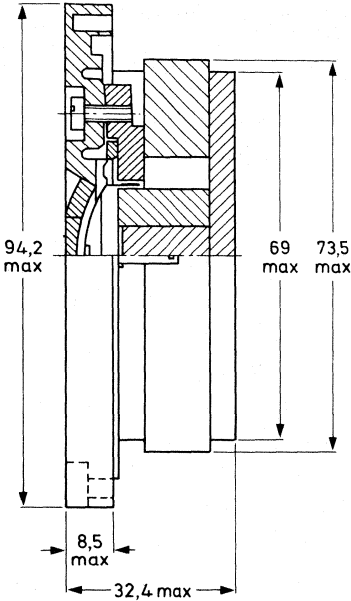

Fig. 2.

7269999.1

One tag is indicated by a red mark for in-phase connection. Face of loudspeaker should not lie behind plane of baffle.

AVAILABLE VERSIONS

AD01634/T4, catalogue number 2422 257 33431
 AD01634/T8, catalogue number 2422 257 33432

these numbers apply to bulk packed loudspeakers, minimum packing quantity 30 per unit.

FREQUENCY RESPONSE CURVES (See Fig. 3)

Measured in anechoic room at the operating power. Loudspeaker mounted on IEC baffle.
 Curve a: Sound pressure.
 Curve d2: 2nd harmonic distortion.

DEVELOPMENT SAMPLE DATA

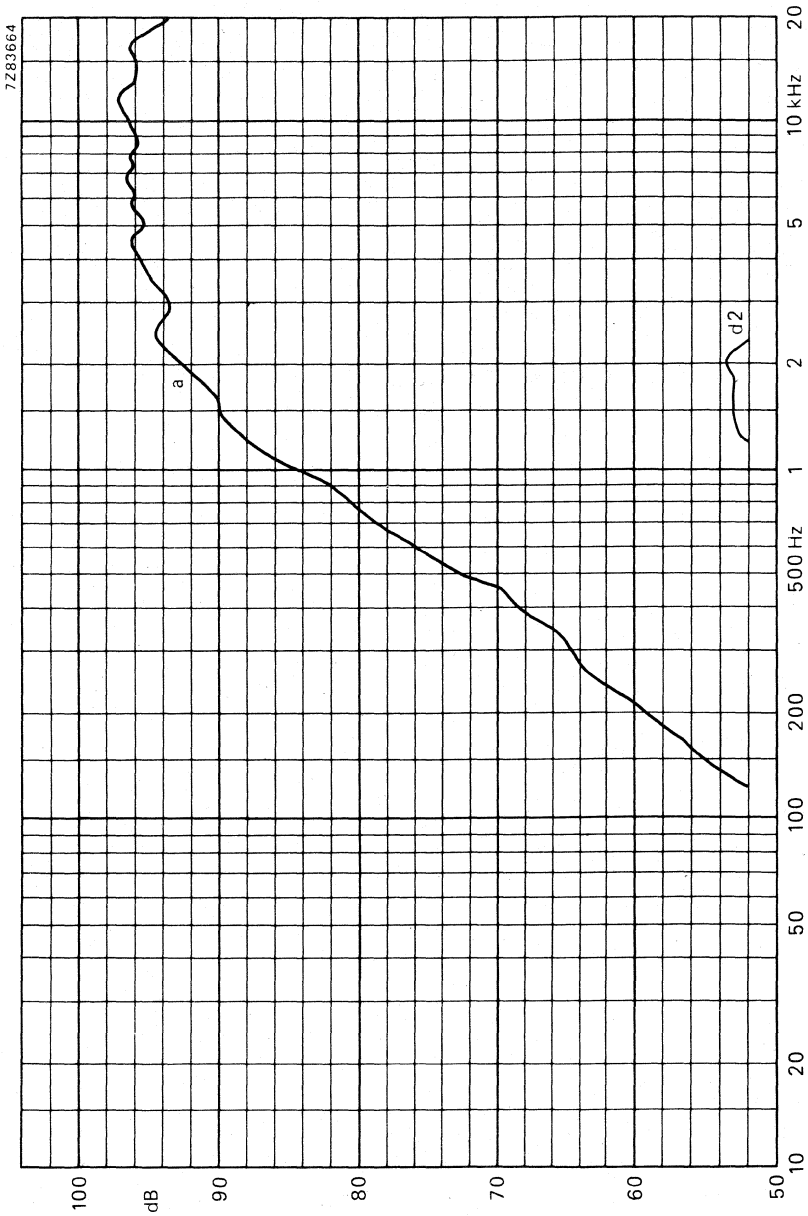

Fig. 3.



2 INCH HIGH POWER TWEETER LOUSPEAKERS

APPLICATION

For the reproduction of frequencies up to 20 kHz with very low distortion in multi-way high-fidelity loudspeaker systems in accordance with DIN 45500. This loudspeaker may be used in television sets, due to absence of stray field from the tweeter magnet system.

TECHNICAL DATA

	version			
	T4	T8	T15	
Rated impedance	4	8	15 Ω	
Voice coil resistance	3,3	6,3	13,5 Ω	←
Resonance frequency		1300	Hz	
Rated frequency range		3000 to 20 000	Hz	←
Power handling capacity at + 50 °C, loudspeaker unmounted, of loudspeaker only		3	W	
of system, crossover frequency 3000 Hz (-3 dB), loudspeaker in series with capacitor of	10	6	W	
Operating power		5	2,7 μ F	←
Sweep voltage (600 to 17 000 Hz) loudspeaker in series with capacitor of	3,5	6	W	
Energy in air gap	12	4,9	6,7 V	
Flux density		5	2,7 μ F	
Air-gap height		15,5	mJ	
Voice coil height		0,73	T	
Core diameter		2,25	mm	
Magnet material	2,0	2,9	2,8 mm	
diameter		14,5	mm	
mass		0,013	kg	
Mass of loudspeaker		0,05	kg	

The loudspeaker has a paper cone and surround. Connection to the loudspeaker by means of 2,8 mm (0,11 inch) tag connectors or by soldering.

AD2096/T.
AD2296/T.

Dimensions in mm

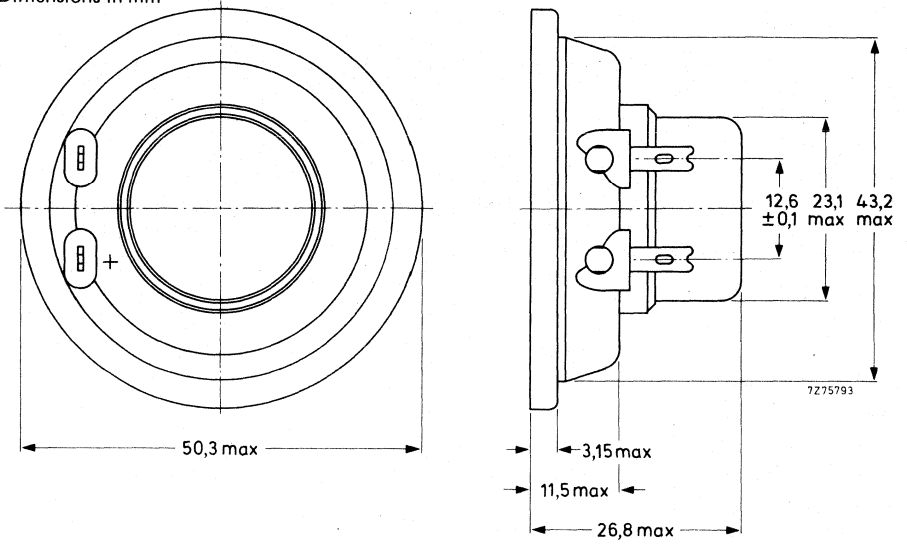

Fig. 1a Round flange type AD2096/T.

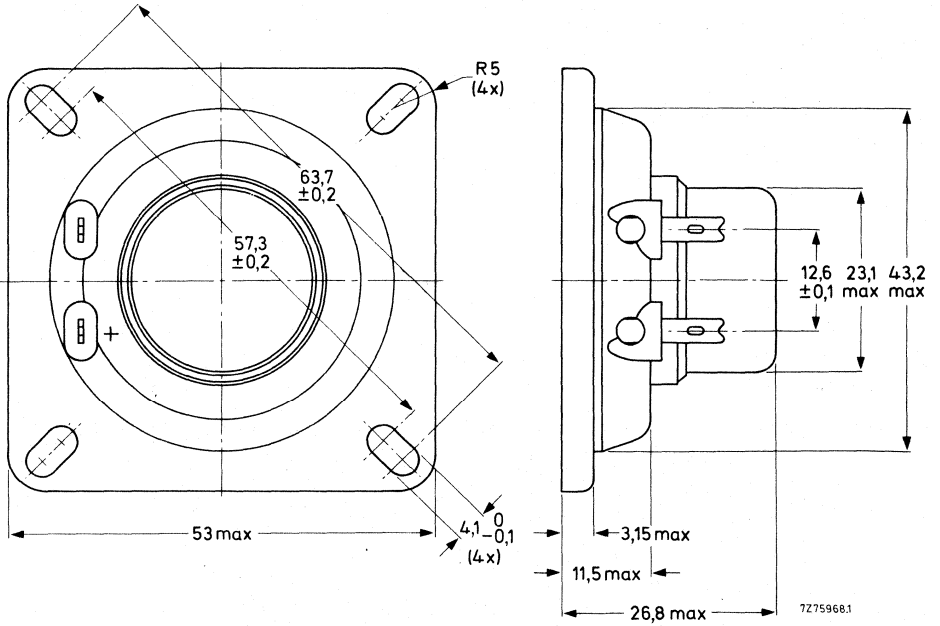

Fig. 1b Square flange type AD2296/T.

One tag is indicated by + sign for in-phase connection.

AVAILABLE VERSIONS

Round flange type (Fig. 1a)

AD2096/T4, catalogue number 2422 256 32321
AD2096/T8, catalogue number 2422 256 32322
AD2096/T15, catalogue number 2422 256 32323

Square flange type (Fig. 1b)

AD2296/T4, catalogue number 2422 256 32331
AD2296/T8, catalogue number 2422 256 32332
AD2296/T15, catalogue number 2422 256 32333

FREQUENCY RESPONSE CURVE (see Fig. 2)

Measured in anechoic room at a power of 1,5 W, loudspeaker unmounted.

Curve a: Sound pressure.

Curves d2 and d3: 2nd and 3rd harmonic distortion.

these numbers apply to bulk
packed loudspeakers, minimum
packing quantity 100 per unit.



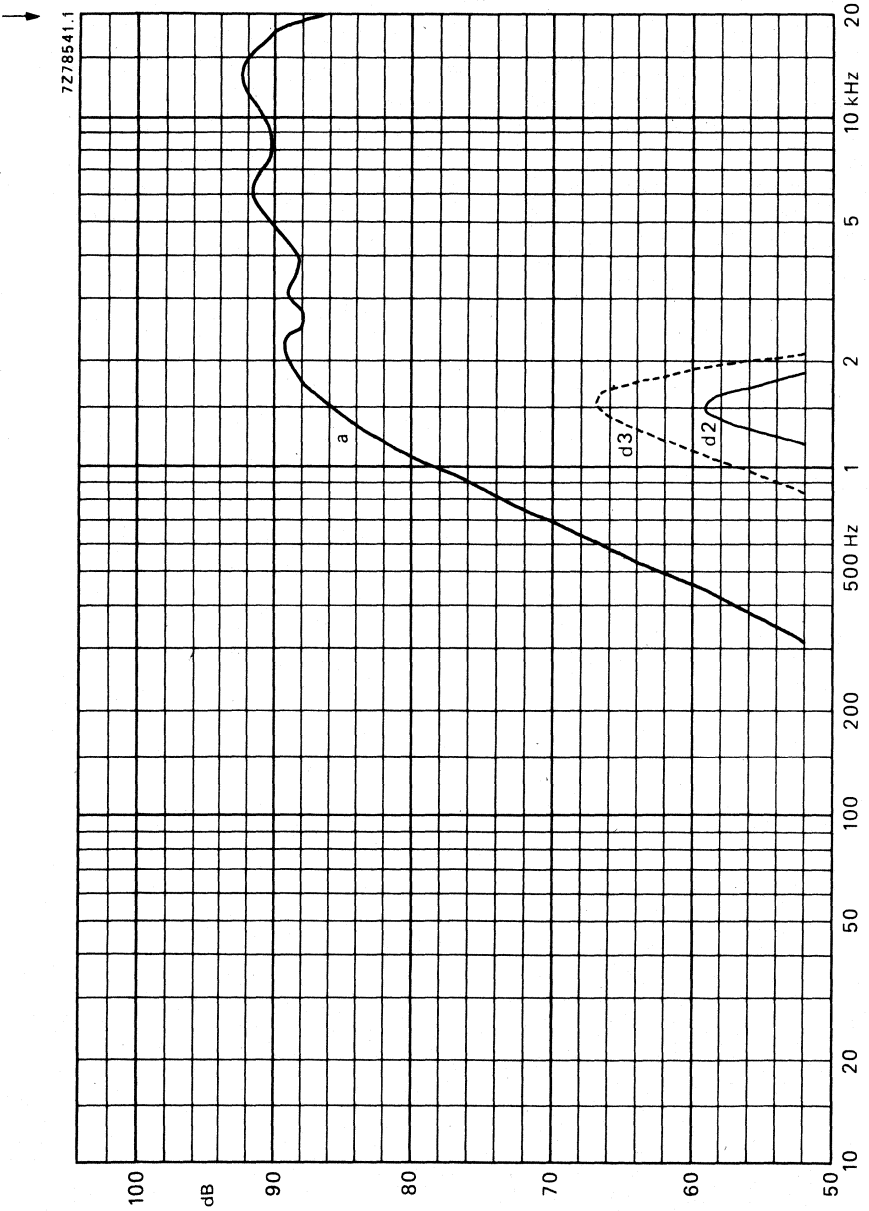

Fig. 2.

DEVELOPMENT SAMPLE DATA

This information is derived from development samples made available for evaluation. It does not necessarily imply that the device will go into regular production.

AD22300/T.

2 INCH HIGH POWER TWEETER LOUDSPEAKER

APPLICATION

For the reproduction of high frequencies in multi-way high-fidelity loudspeaker systems. Minimum recommended crossover frequency 3000 Hz with 3 dB/octave slope.

TECHNICAL DATA

	versions		
	T4	T8	T15
Rated impedance	4	8	15 Ω
Voice coil resistance	3,4	6,3	13,5 Ω
Rated frequency range	3000 to 17 000 Hz		
Resonance frequency	1300		Hz
Power handling capacities, loudspeaker unmounted, C = 10 μ F in series	3		W
C = 5 μ F in series		3	W
C = 2,7 μ F in series			3 W
Operating power		6	W
Maximum power		6	W
Sweep voltage, frequency range: 600 to 17 000 Hz high pass filter: 10 μ F in series	3,5		V
5 μ F in series		4,9	V
2,7 μ F in series			6,7 V
Energy in air gap		21,5	mJ
Flux density		0,8	T
Air-gap height		2,5	mm
Voice coil height	2	2,9	2,8 mm
Core diameter		14,5	mm
Magnet material	ceramic		
diameter		90	mm
mass		0,029	kg
Mass of loudspeaker		0,08	kg

The loudspeaker has a paper cone. Two tinned 2,8 mm (0,11 inch) tag connectors permit connection to the tweeter by plugging or soldering.



Dimensions in mm

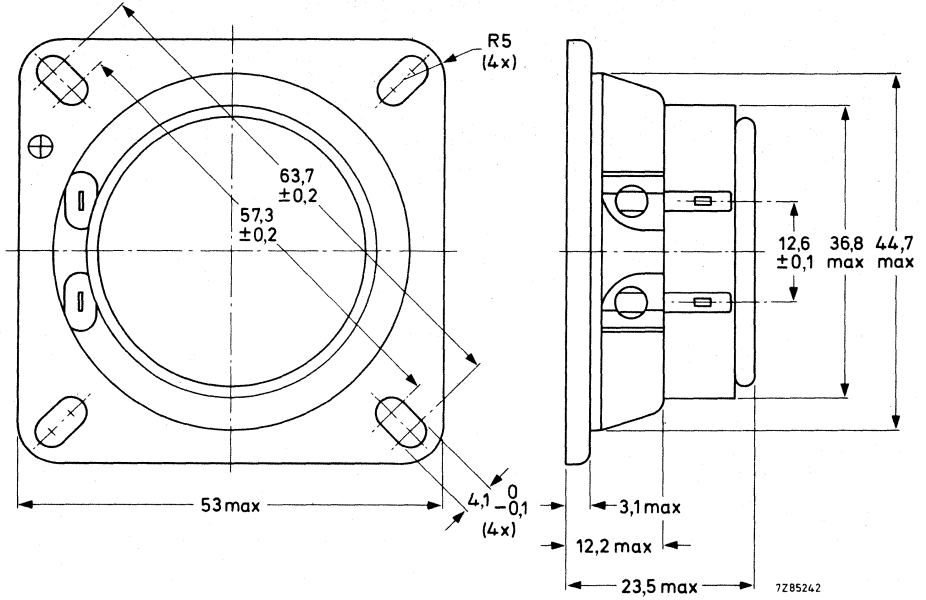

Fig. 1.

One tag is indicated by a + sign for in-phase connection.

AVAILABLE VERSIONS

AD22300/T4 catalogue number 2422 257 32531 } these numbers apply to bulk packed loudspeakers,
 AD22300/T8 catalogue number 2422 257 32532 } minimum packing quantity 10 per unit.
 AD22300/T15 catalogue number 2422 257 32533 }

FREQUENCY RESPONSE CURVES (see Fig. 2)

Measured in anechoic room at the operating power. Loudspeaker mounted on IEC baffle according to IEC 268-5 para. 4.4.

Curve a: Sound pressure.

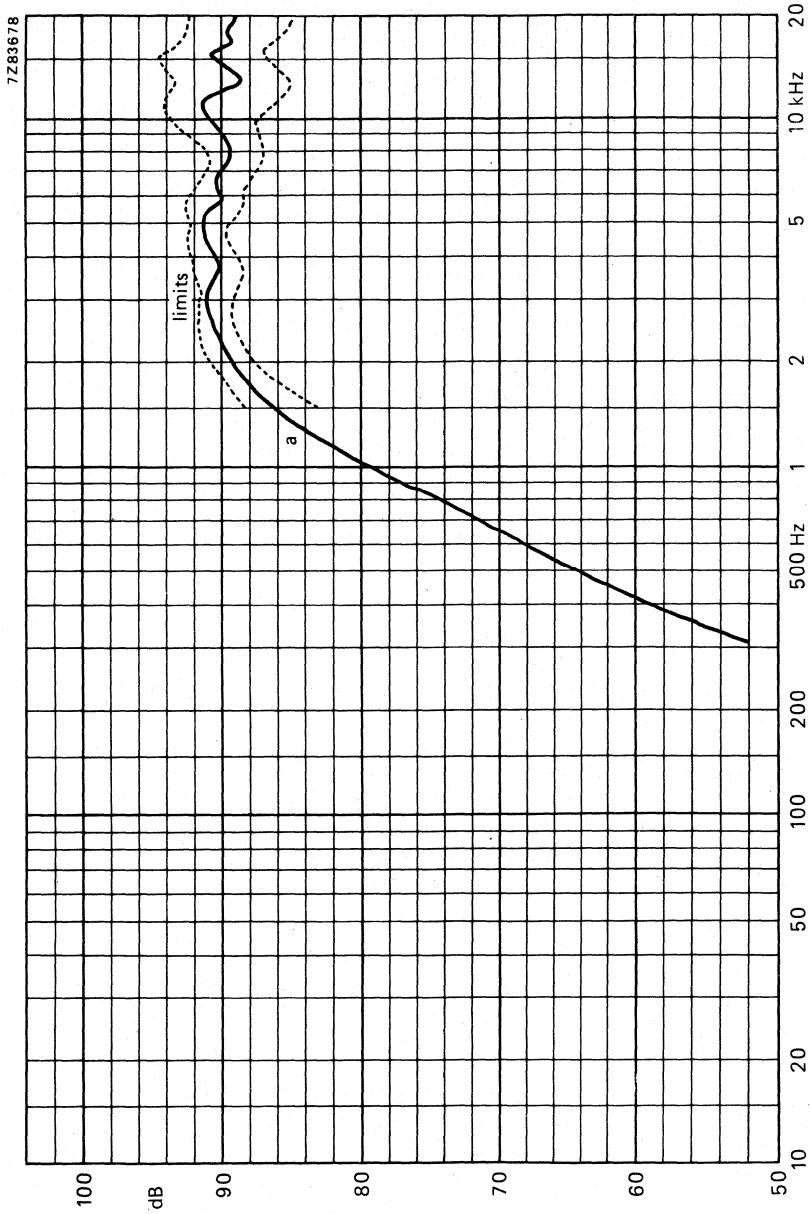

Fig. 2.



2¼ INCH HIGH POWER TWEETER LOUDSPEAKERS

APPLICATION

For acoustic enclosures. Type AD2274/T. is also very suitable for television sets because this type is provided with a magnetic shield.

TECHNICAL DATA

	versions	
	T4	T8
Rated impedance	4	8 Ω
Voice coil resistance	3,5	7,1 Ω
Rated frequency range	1500 to 15 000 Hz	
Resonance frequency	1000 Hz	
Power handling capacity, measured with a series capacitor of 5 μF and a signal acc. DIN 45573 cross-over frequency 2400 Hz loudspeaker unmounted	10 W	
Sweep voltage (700 to 15 000 Hz)	1,4	2 V
Energy in air gap	12,7 mJ	
Flux density	740 T	
Air-gap height	2,5 mm	
Voice coil height	2,7	2,2 mm
Core diameter	10 mm	
Magnet material	ceramic	
diameter	28,5 mm	
mass	0,018 kg	
Mass of loudspeaker	0,07 kg	

The loudspeakers have a paper cone and surround. Connection to the loudspeakers by means of 2,8 mm (0,11 inch) tag connectors or by soldering.

AD2273/T.
AD2274/T.

Dimensions (mm)

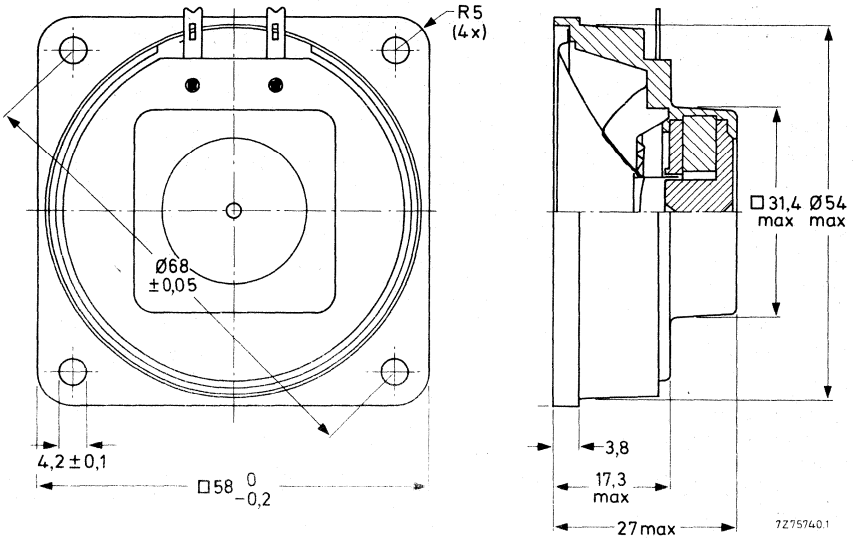

Fig. 1.

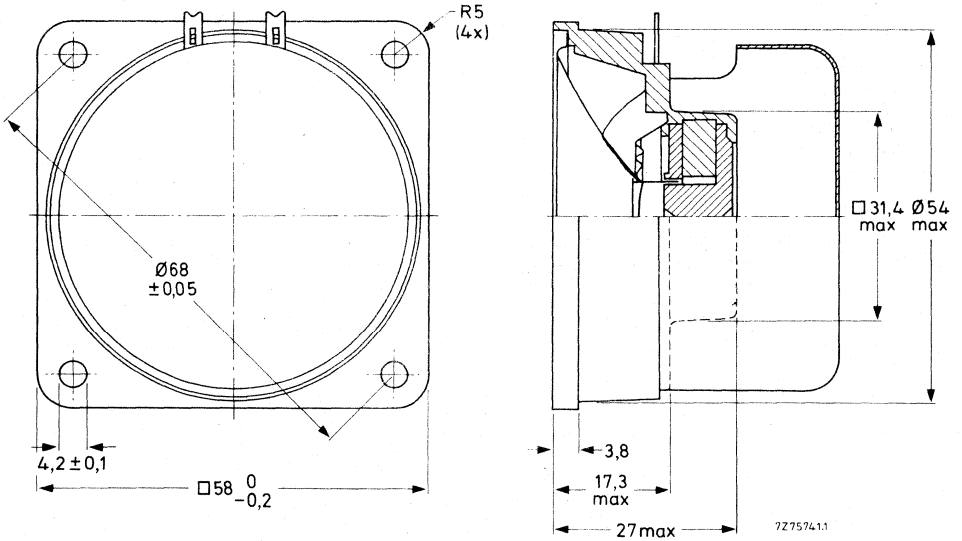

Fig. 2.

One tag is indicated by a red mark for in-phase connection.

AVAILABLE VERSIONS

Without magnetic shield, Fig: 1

AD2273/T4, catalogue number 2403 257 22121

AD2273/T8, catalogue number 2403 257 22122

With magnetic shield, Fig: 2

AD2274/T4, catalogue number 2403 257 22221

AD2274/T8, catalogue number 2403 257 22222

these numbers apply to bulk packed loudspeakers, minimum packing quantity 50 per unit.

RESPONSE CURVES

Input power 50 mW.

Sound pressure measured in anechoic room, loudspeaker unmounted.

Fig. 3 Directional curve at 10 000 Hz.

Fig. 4 Frequency response curve. Over the width of one octave, the characteristic may be maximum 2 dB lower than indicated.

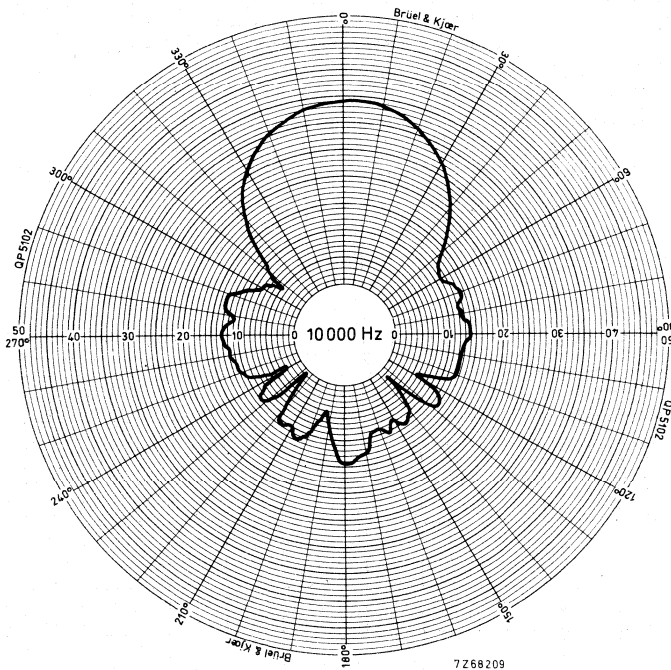

Fig. 3.

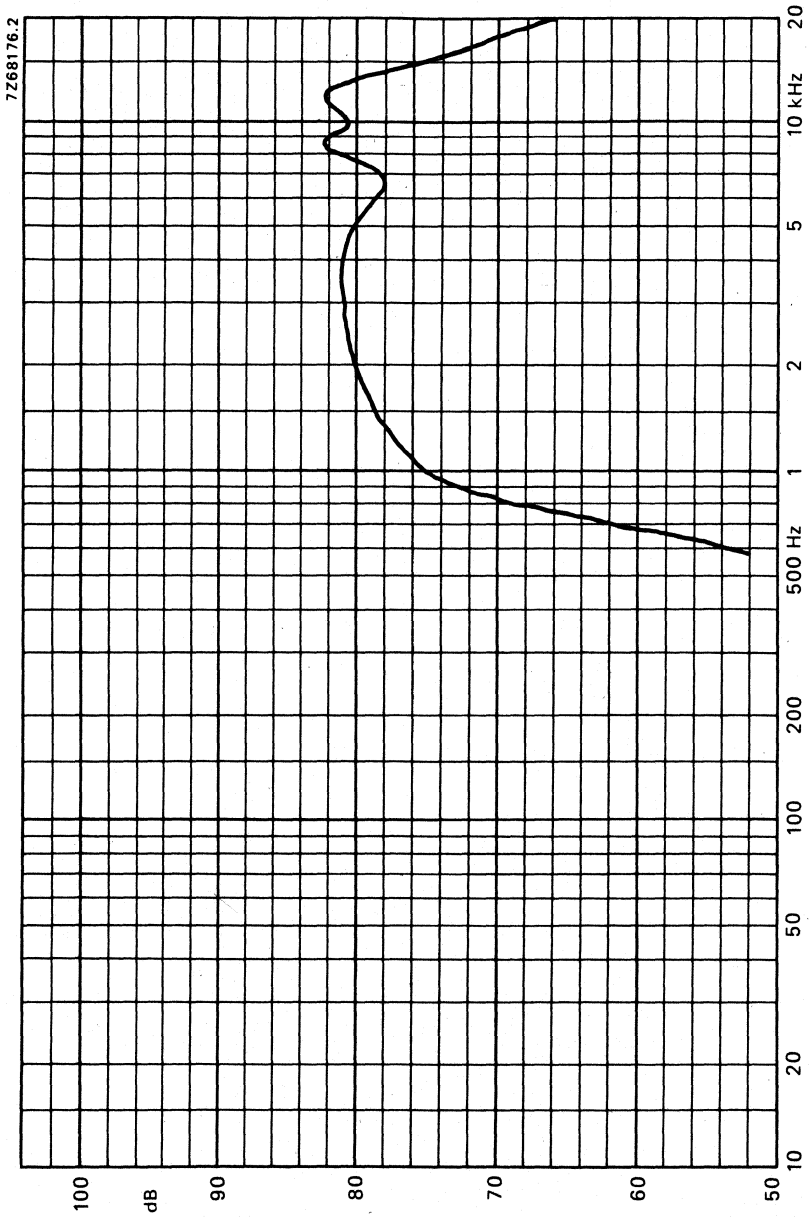
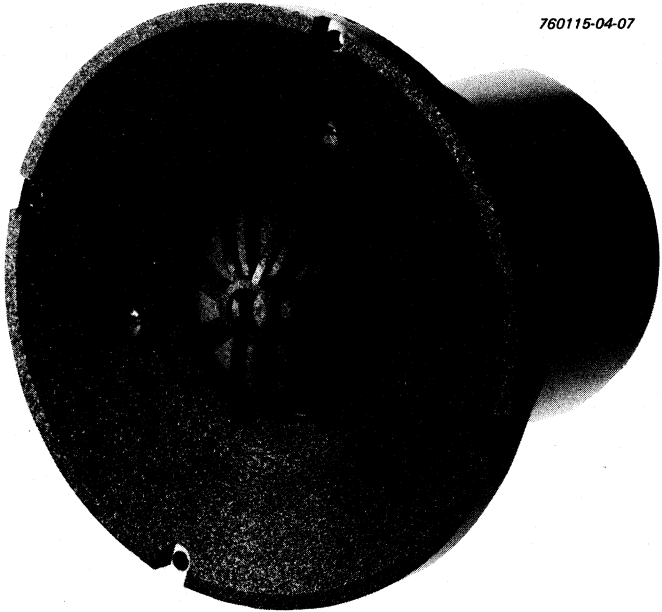

Fig. 4.

HIGH POWER SQUAWKER LOUDSPEAKERS



760115-04-07



Type AD0210/Sq4



Dimensions in mm

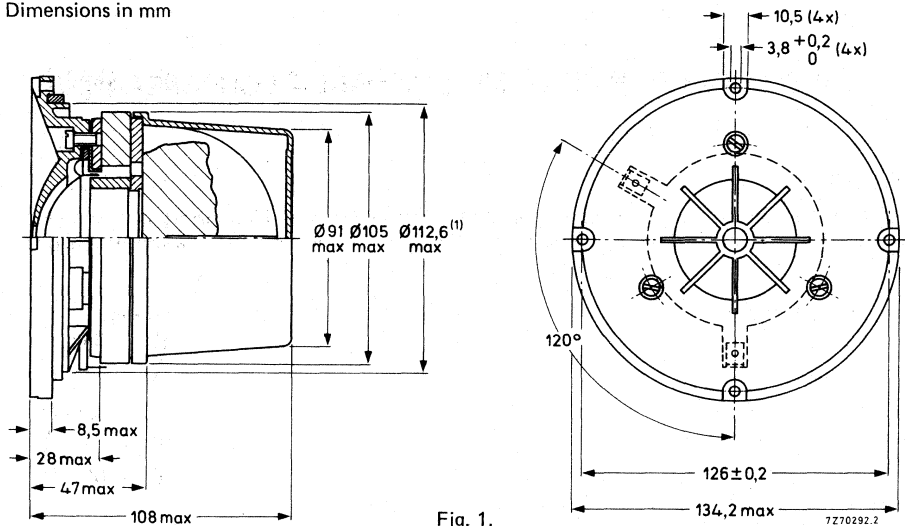

Fig. 1.

→ (1) Baffle hole diameter 113 mm.

One tag is indicated by a red mark for in-phase connection.

→ **AVAILABLE VERSIONS**

With paper dome

AD0210/Sq4, catalogue number 2422 257 32021

AD0210/Sq8, catalogue number 2422 257 32022

With textile dome

AD0211/Sq4, catalogue number 2422 257 32031

AD0211/Sq8, catalogue number 2422 257 32032

} these numbers apply to bulk packed loudspeakers, minimum packing quantity 12 per unit.

FREQUENCY RESPONSE CURVES (see Fig. 2)

Curve a: Sound pressure measured in anechoic room, loudspeaker mounted on IEC baffle at operating power.

Curves d2 and d3: 2nd and 3rd harmonic distortion, measured at the operating power in anechoic room. Loudspeaker front mounted on IEC baffle.

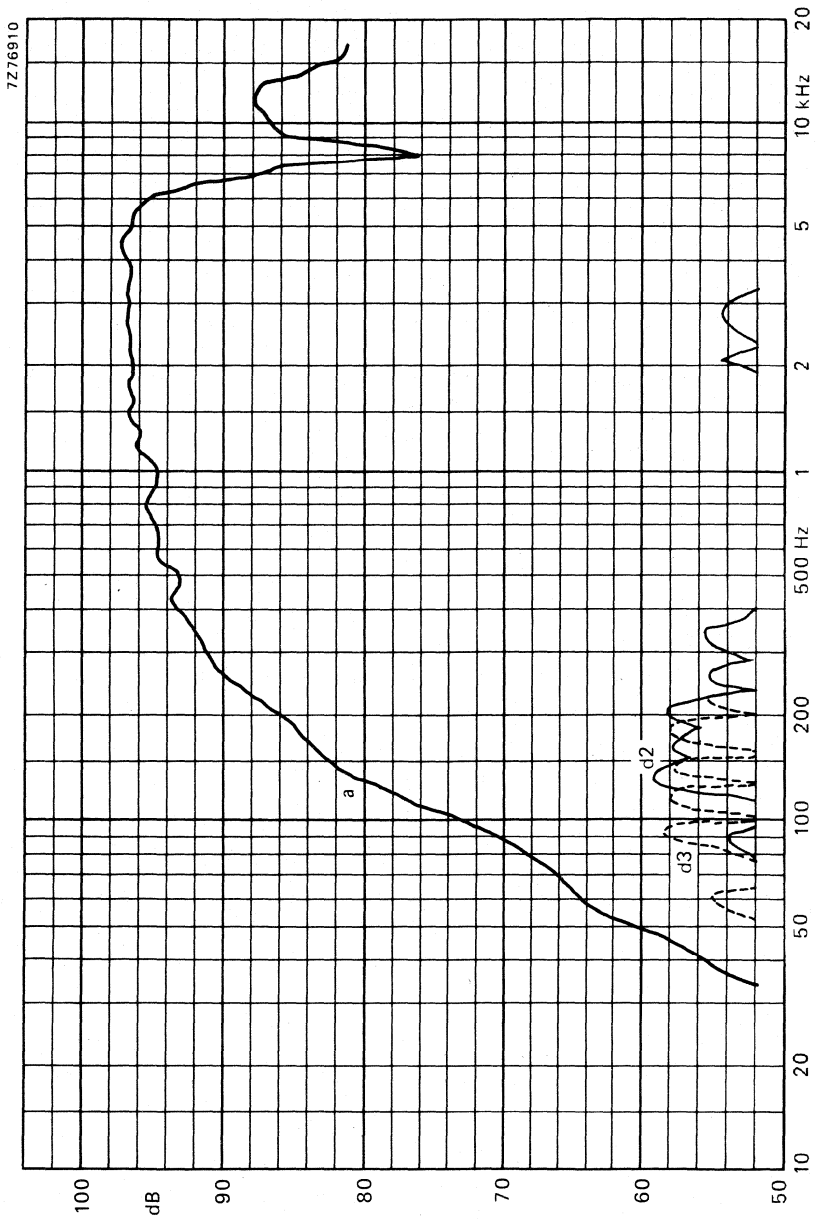

Fig. 2.



DEVELOPMENT SAMPLE DATA

This information is derived from development samples made available for evaluation. It does not necessarily imply that the device will go into regular production.

AD02110/Sq.

2 INCH HIGH POWER DOME SQUAWKER LOUDSPEAKER

APPLICATION

For use in hi-fi enclosures. This loudspeaker has a very wide radiating pattern due to its nearly flat conical front.

TECHNICAL DATA

	version	
	Sq4	Sq8
Rated impedance	4	8 Ω
Voice coil resistance	3,4	6,9 Ω
Resonance frequency	340	360 Hz
Rated frequency range	550 to 5000 Hz	
Power handling capacity, * loudspeaker mounted on IEC baffle, measured with filter		
36 μ F – 1,2 mH	30	W
18 μ F – 2,4 mH		30 W
Maximum power on loudspeaker	60	W
Operating power	4	W
Sweep voltage (100 to 10 000 Hz, filter 36 μ F – 1,2 mH 18 μ F – 2,4 mH)	4	V
		5,6 V
Energy in air gap	205	mJ
Flux density	0,9	T
Air-gap height	3	mm
Voice coil height	3,3	mm
Core diameter	50	mm
Magnet material	ceramic	
diameter	102	mm
mass	0,35	kg
Mass of loudspeaker	1	kg

The loudspeaker has a textile dome and an acoustically sealed pot. No isolation is required. Connection to the squawker by means of 2,8 mm (0,11 inch) tag connectors or by soldering.

* Measured according to DIN 45573 par. 3.2.

Dimensions in mm

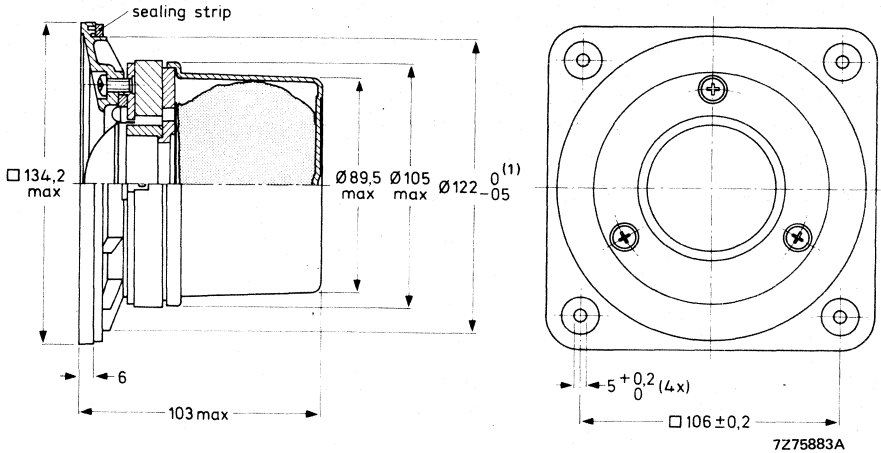

Fig. 1.

(1) Baffle hole diameter 122 mm.

One tag is indicated by a red mark for in-phase connection.

→ **AVAILABLE VERSIONS**

AD02110/Sq4, catalogue number 2422 257 32221 | these numbers apply to bulk packed loudspeakers,
 AD02110/Sq8, catalogue number 2422 257 32222 | minimum packing quantity 8 per unit.

FREQUENCY RESPONSE CURVES (see Fig. 2)

Measured in anechoic room, loudspeaker mounted on IEC baffle at operating power. Above 500 Hz the sound pressure may not deviate more than ± 1 dB.

Curve a: Sound pressure.

Curves d2 and d3: 2nd and 3rd harmonic distortion.



DEVELOPMENT SAMPLE DATA

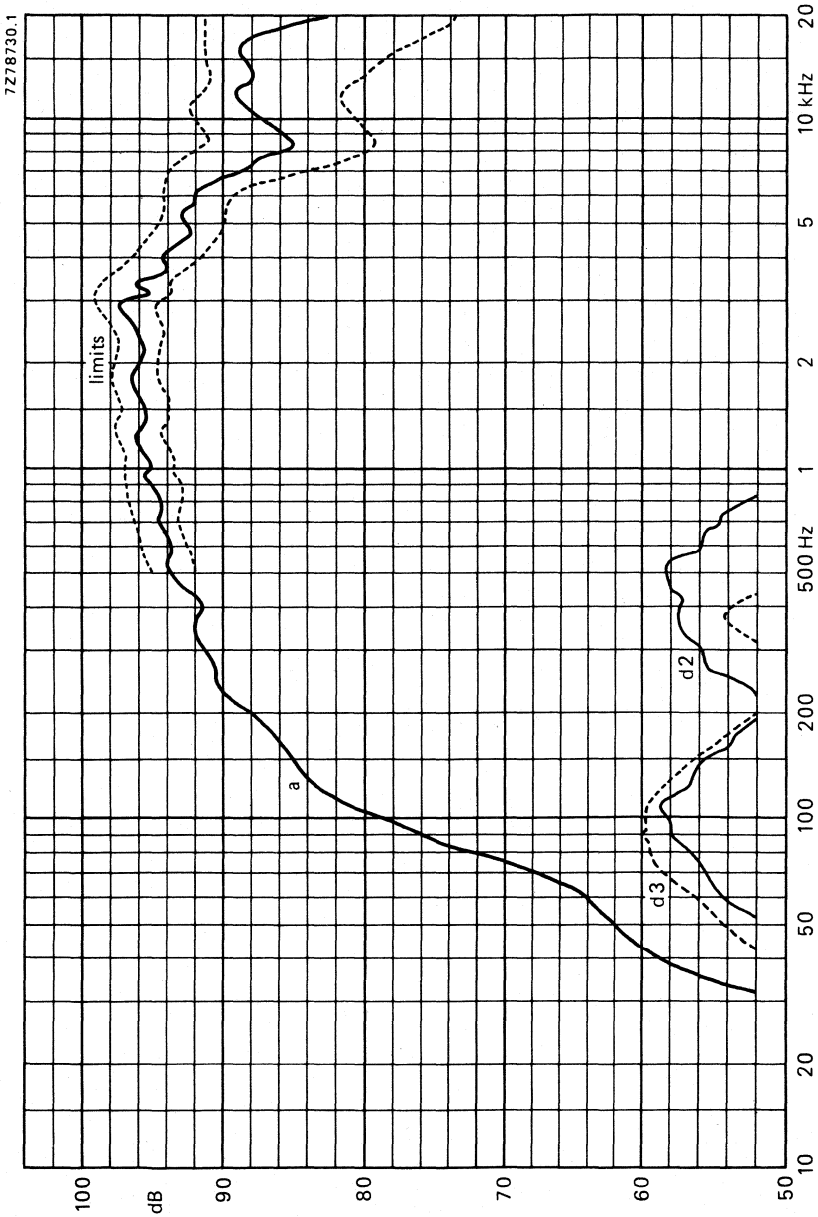

Fig. 2.



Dimensions in mm

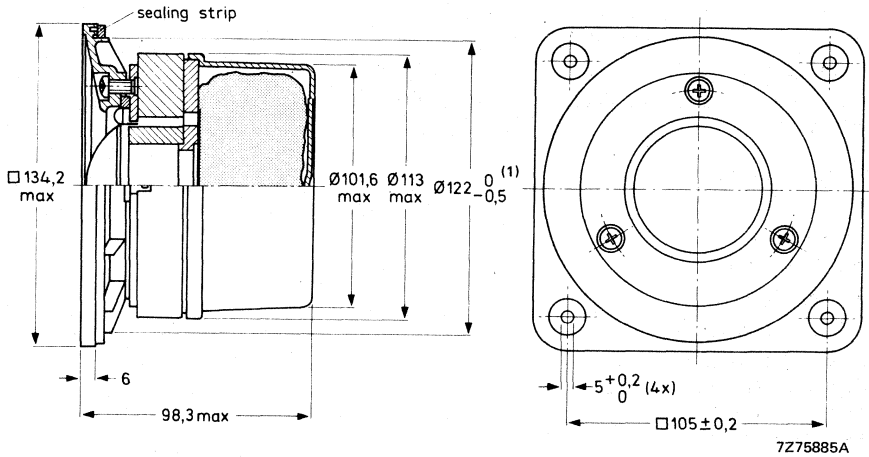

Fig. 1.

(1) Baffle hole diameter 122 mm.

One tag is indicated by a red mark for in-phase connection.

→ **AVAILABLE VERSIONS**

AD02150/Sq4, catalogue number 2422 257 32321 } these numbers apply to bulk packed loudspeakers,
 AD02150/Sq8, catalogue number 2422 257 32322 } minimum packing quantity 8 per unit.

FREQUENCY RESPONSE CURVES (see Fig. 2)

Measured in anechoic room, loudspeaker mounted on IEC baffle at operating power. Above 500 Hz the sound pressure may not deviate more than ± 1 dB.

Curve a: Sound pressure.

Curves d2 and d3: 2nd and 3rd harmonic distortion.



DEVELOPMENT SAMPLE DATA

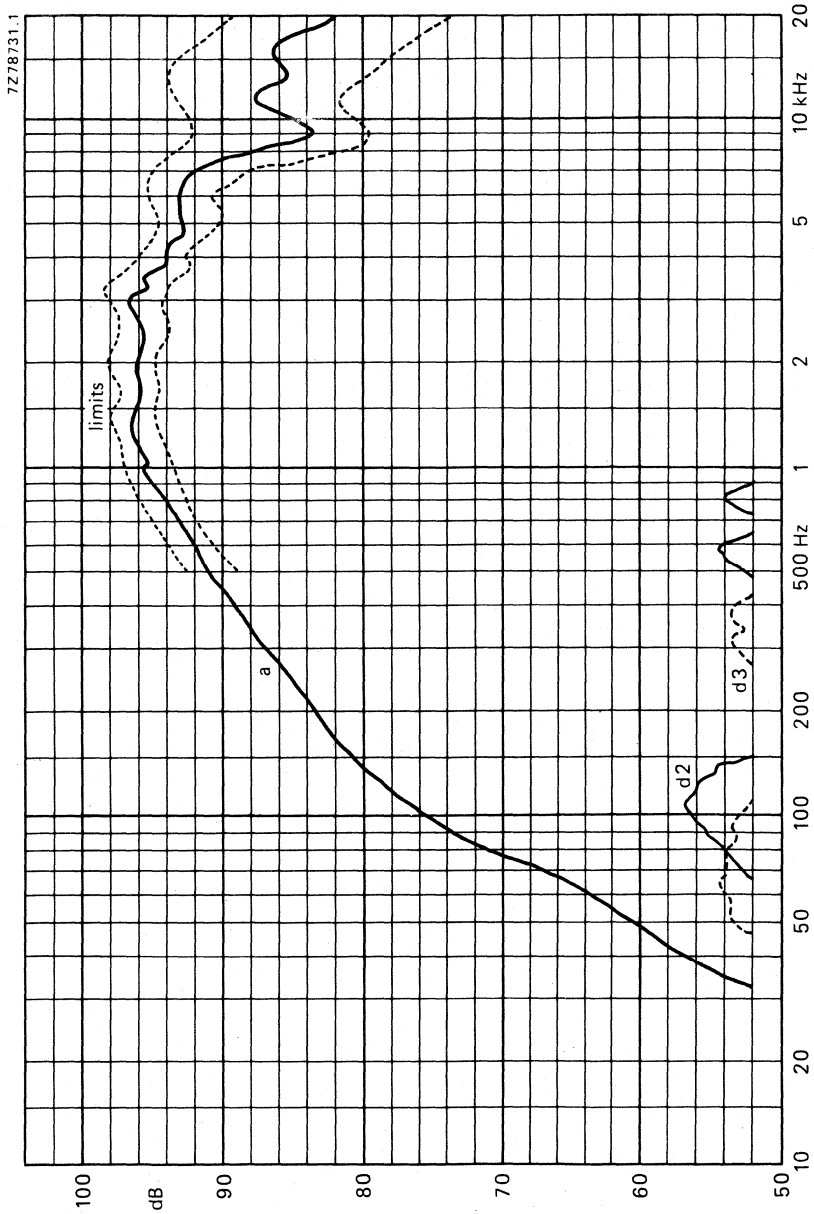

Fig. 2.



2 INCH HIGH POWER DOME SQUAWKER LOUDSPEAKERS

APPLICATION

For the reproduction of audio frequencies from 550 to 5000 Hz with very low distortion in multi-way high-fidelity loudspeaker systems in accordance with DIN 45500. The loudspeaker has an excellent spherical radiation pattern.

TECHNICAL DATA

	version	
	Sq4	Sq8
Rated impedance	4	8 Ω
Voice coil resistance	3,4	6,9 Ω
Resonance frequency	340	360 Hz
Rated frequency range	550 to 10 000 Hz	
Power handling capacity,* loudspeaker mounted on IEC baffle, measured with filter:		
36 μ F – 1,2 mH	30	W
18 μ F – 2,4 mH		30 W
Maximum power on loudspeaker	60	W
Operating power	4	W
Sweep voltage, frequency range: 100 – 10 000 Hz, high-pass filter:		
36 μ F – 1,2 mH	4	V
18 μ F – 2,4 mH		5,6 V
Energy in air gap	288	mJ
Flux density	1,1	T
Air-gap height	3	mm
Voice coil height	3,3	mm
Core diameter	50	mm
Magnet material	ceramic	
diameter	110	mm
mass	0,65	kg
Mass of loudspeaker	1,5	kg

The loudspeakers have a textile dome and an acoustically sealed pot. No isolation is required. Type AD02161/SQ is a "de luxe" version with two aluminium rings at the front. Connection to the squawkers by means of 2,8 mm (0,11 inch) tag connectors or by soldering.

* Measured according to DIN 45573 par. 3.2.

Dimensions in mm

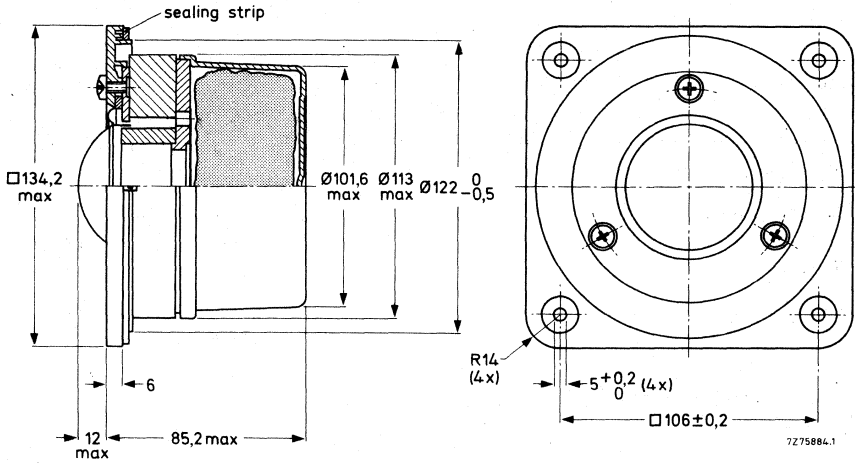

Fig. 1.

* Baffle hole diameter 122 mm.

One tag is indicated by a red mark for in-phase connection.

AVAILABLE VERSIONS

- AD02160/Sq4, catalogue number 2422 257 32331
- AD02160/Sq8, catalogue number 2422 257 32332
- AD02161/Sq4, catalogue number 2422 257 32335
- AD02161/Sq8, catalogue number 2422 257 32336

these numbers apply to bulk packed loudspeakers, minimum packing quantity 24 per unit.

FREQUENCY RESPONSE CURVES (See Fig. 2)

Measured in anechoic room, loudspeaker mounted on IEC baffle at operating power. Above 500 Hz the sound pressure may not deviate more than ± 1 dB.

Curve a: Sound pressure.

Curves d2 and d3: 2nd and 3rd harmonic distortion.



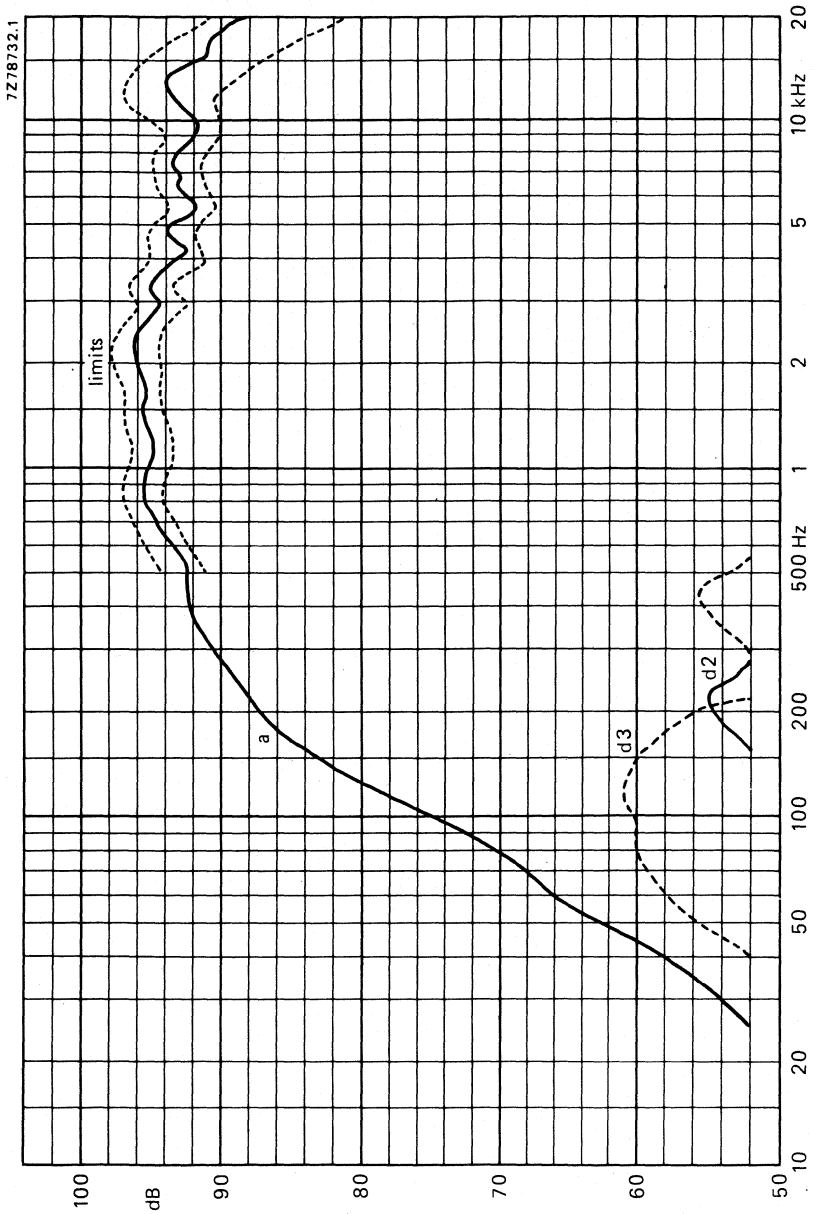

Fig. 2.



5 inch HIGH POWER SQUAWKER LOUDSPEAKER

APPLICATION

For the reproduction of audio frequencies from 500 to 4500 Hz with very low distortion in multi-way high-fidelity loudspeaker systems in accordance with DIN45500. The loudspeaker has an excellent spherical radiation pattern.

TECHNICAL DATA

	version	
	Sq4	Sq8
Rated impedance	4	8 Ω
Voice coil resistance	3,4	6,4 Ω
Resonance frequency	210	Hz
Power handling capacity, loudspeaker unmounted of loudspeaker only	10	W
of system, measured with filter: 72 μ F – 2,1 mH	30	W
36 μ F – 4,5 mH		30 W
Operating power	4	W
Sweep voltage		
frequency range: 400 – 5000 Hz (–3 dB)		
filter high pass: 72 μ F – 2,1 mH	3,5	V
36 μ F – 4,5 mH		5 V
Energy in air gap	140	mJ
Flux density	0,93	T
Air-gap height	5	mm
Voice coil height	6	6,6 mm
Core diameter	25	mm
Magnet material	ceramic	
diameter	72	mm
mass	0,23	kg
Mass of loudspeaker	0,8	kg

The loudspeaker has a paper cone, a textile surround and a sealed pot: no acoustic isolation required. Connection to the loudspeaker by means of 6,3 mm (0,25 inch) tag connectors or by soldering.

Dimensions (mm)

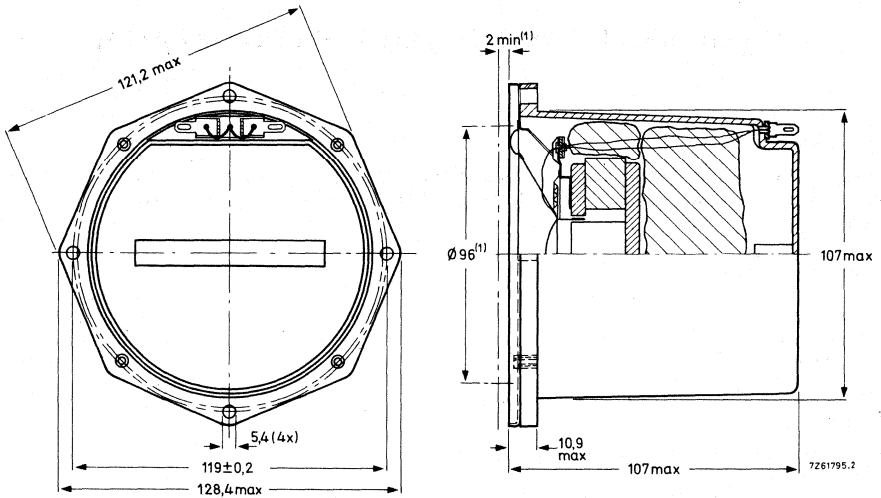

Fig. 1.

(1) Baffle hole and clearance depth required for cone movement at the specified power handling capacity. One tag is indicated by a red mark for in-phase connection.

→ **AVAILABLE VERSIONS**

AD5060/Sq4, catalogue number 2422 257 35421 } these numbers apply to bulk packed loudspeakers,
 AD5060/Sq8, catalogue number 2422 257 35422 } minimum packing quantity 24 per unit.

FREQUENCY RESPONSE CURVES (see Fig. 2)

Measured in half free field at operating power of 4 W in anechoic room, loudspeaker mounted on IEC baffle.

Curve a: Sound pressure.

Curves d2 and d3: 2nd and 3rd harmonic distortion.



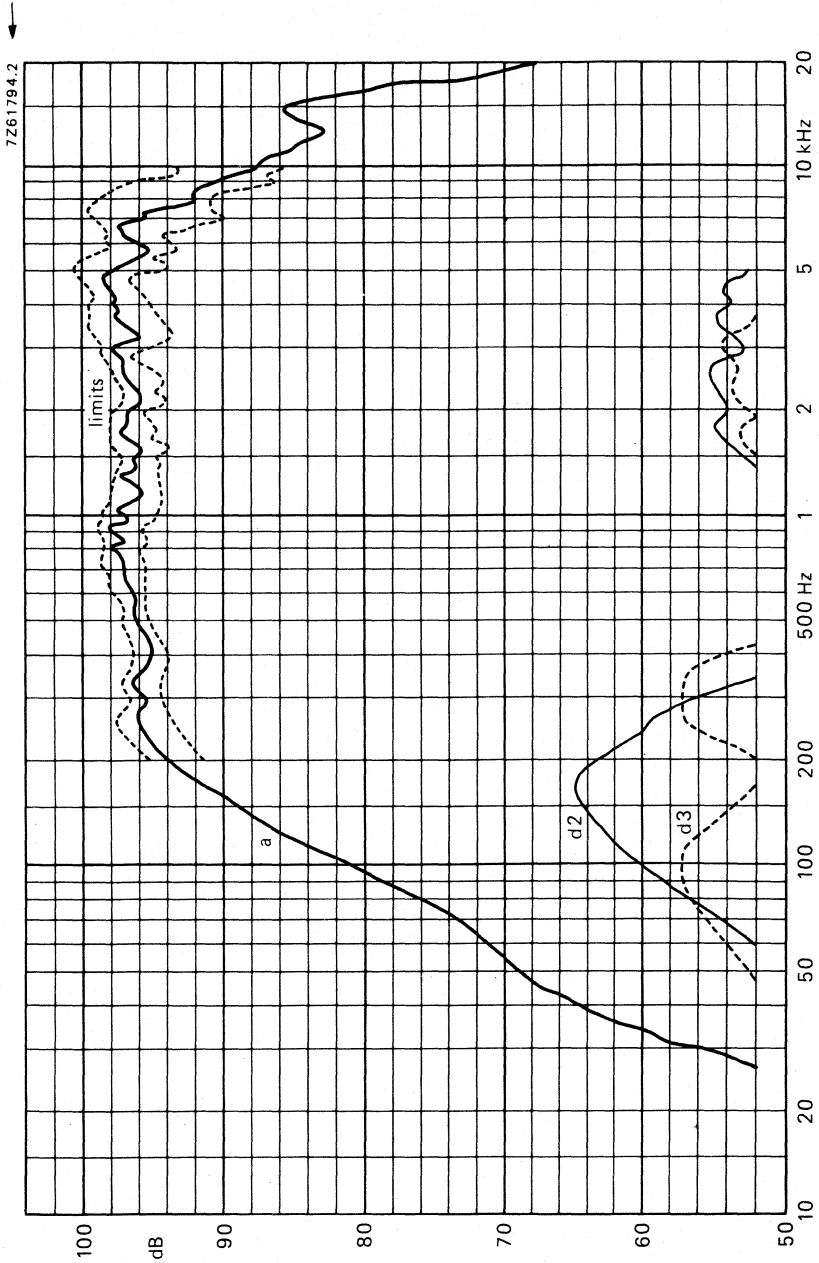

Fig. 2.



DEVELOPMENT SAMPLE DATA

This information is derived from development samples made available for evaluation. It does not necessarily imply that the device will go into regular production.

AD50600/Sq.

5 INCH HIGH POWER SQUAWKER LOUDSPEAKER

APPLICATION

For the reproduction of audio frequencies from 400 to 5000 Hz with very low distortion in multi-way high-fidelity loudspeaker systems in accordance with DIN 45500. The loudspeaker has an excellent spherical radiation pattern.

TECHNICAL DATA

	version	
	Sq4	Sq8
Rated impedance	4	8 Ω
Voice coil resistance	3,4	7 Ω
Rated frequency range	400 to 5000 Hz	
Resonance frequency	260 Hz	
Power handling capacity of system, measured with filter:		
72 μ F – 2,1 mH	20	W
36 μ F – 4,5 mH		20 W
Operating power	4	W
Sweep voltage, frequency range: 400 – 5000 Hz, high-pass filter:		
72 μ F – 2,1 mH	4	V
36 μ F – 4,5 mH		5,6 V
Energy in air gap	140	mJ
Flux density	0,93	T
Air-gap height	5	mm
Voice coil height	6,8	mm
Core diameter	25	mm
Magnet material	ceramic	
diameter	53	mm
mass	0,23	kg
Mass of loudspeaker	0,7	kg

The loudspeaker has a paper cone, a textile surround and a sealed pot; no acoustic isolation required. Two tinned 2,8 mm (0,11 inch) tag connectors permit connection to the loudspeaker by plugging or soldering.

Dimensions in mm

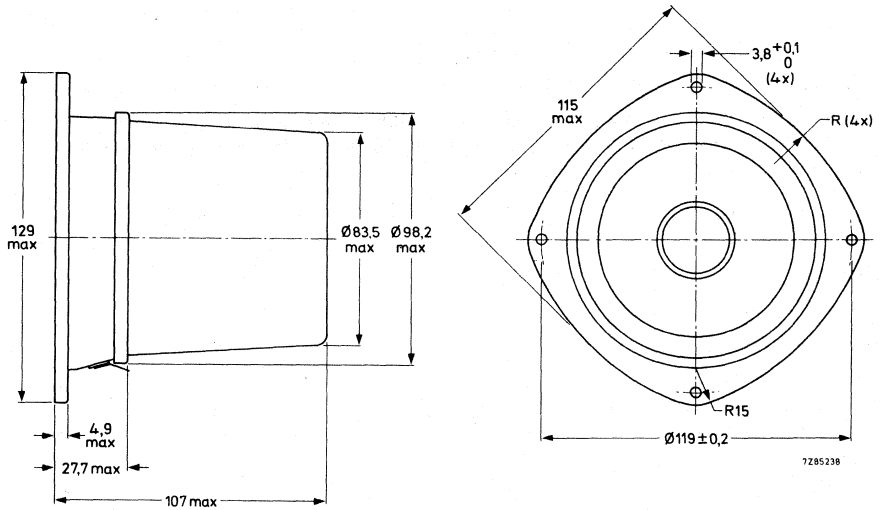

Fig. 1.

Baffle hole diameter minimum 100 mm.

One tag is indicated by a red mark for in-phase connection.

AVAILABLE VERSIONS

AD50600/Sq4, catalogue number 2422 257 45021

AD50600/Sq8, catalogue number 2422 257 45022

these numbers apply to bulk packed loudspeakers, minimum packing quantity 24 per unit.

FREQUENCY RESPONSE CURVES (see Fig. 2)

Measured in anechoic room at the operating power. Loudspeaker mounted on IEC baffle according to IEC 268-5 par. 4-4.

Curve a: Sound pressure.

Curves d2 and d3: 2nd and 3rd harmonic distortion.



DEVELOPMENT SAMPLE DATA

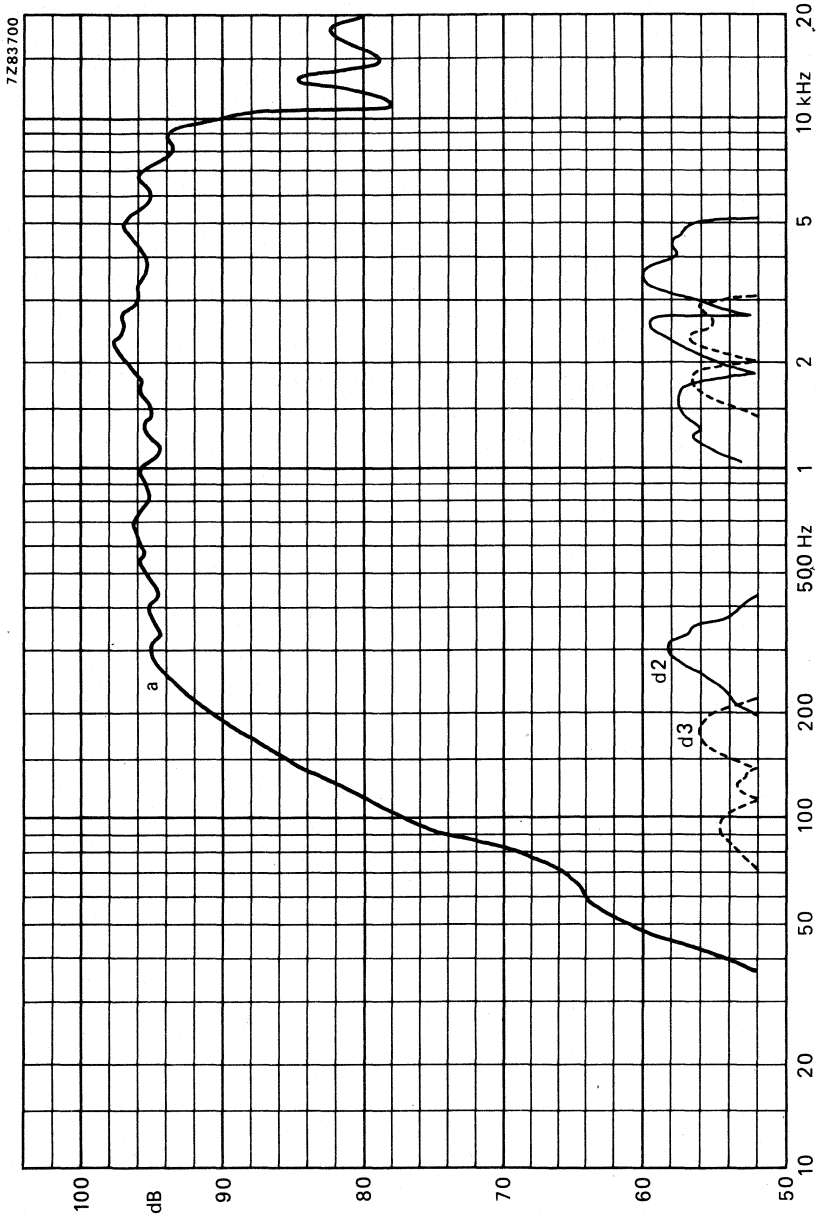

Fig. 2.



DEVELOPMENT SAMPLE DATA

This information is derived from development samples made available for evaluation. It does not necessarily imply that the device will go into regular production.

AD50601/Sq.

5 INCH HIGH POWER SQUAWKER LOUDSPEAKER

APPLICATION

For the reproduction of audio frequencies from 1200 to 5000 Hz with very low distortion in multi-way high-fidelity loudspeaker systems in accordance with DIN 45500. The loudspeaker has an excellent spherical radiation pattern.

TECHNICAL DATA

	version	
	Sq4	Sq8
Rated impedance	4	8 Ω
Voice coil resistance	3,4	7 Ω
Rated frequency range	1200 to 5000	Hz
Resonance frequency	650	Hz
Power handling capacity of system, measured with filter:		
24 μ F – 0,4 mH	20	W
12 μ F – 0,8 mH		20 W
Operating power	4	W
Sweep voltage, frequency range: 300 – 5000 Hz, high-pass filter:		
24 μ F – 0,4 mH	4	V
12 μ F – 0,8 mH		5,6 V
Energy in air gap	140	mJ
Flux density	0,93	T
Air-gap height	5	mm
Voice coil height	6,8	mm
Core diameter	25	mm
Magnet material	ceramic	
diameter	72	mm
mass	0,23	kg
Mass of loudspeaker	0,6	kg

The loudspeaker has a paper cone and a textile surround. Two tinned 2,8 mm (0,11 inch) tag connectors permit connection to the loudspeaker by plugging or soldering.



Dimensions in mm

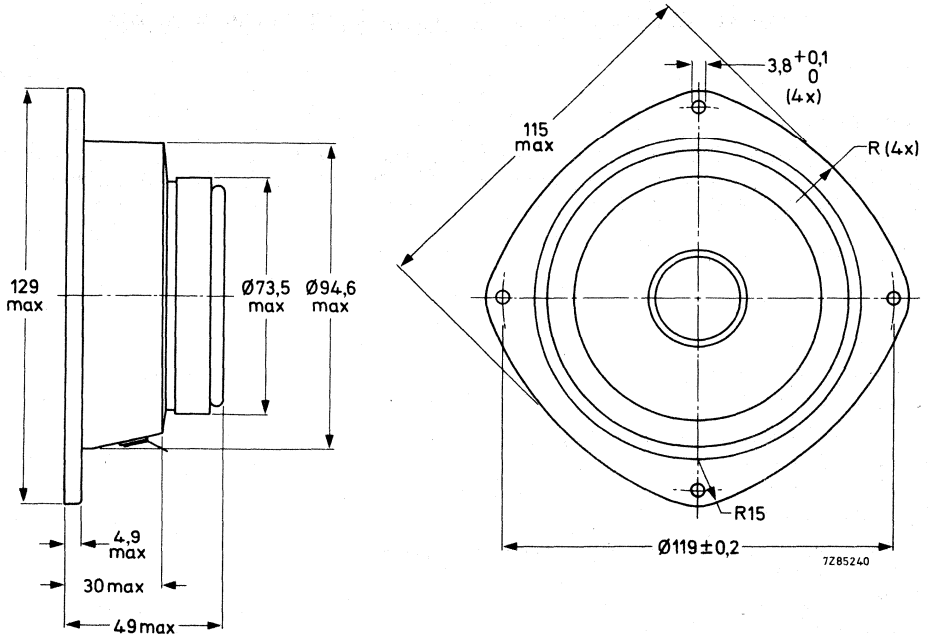

Fig. 1.

Baffle hole diameter minimum 100 mm.

One tag is indicated by a red mark for in-phase connection.

AVAILABLE VERSIONS

AD50601/Sq4, catalogue number 2422 257 45031

AD50601/Sq8, catalogue number 2422 257 45032

these numbers apply to bulk packed loudspeakers, minimum packing quantity 24 per unit.

FREQUENCY RESPONSE CURVE (See Fig. 2)

Measured in anechoic room at the operating power. Loudspeaker mounted on IEC baffle according to IEC 268-5 par. 4.4.

Curve a: Sound pressure.

Curves d2 and d3: 2nd and 3rd harmonic distortion.

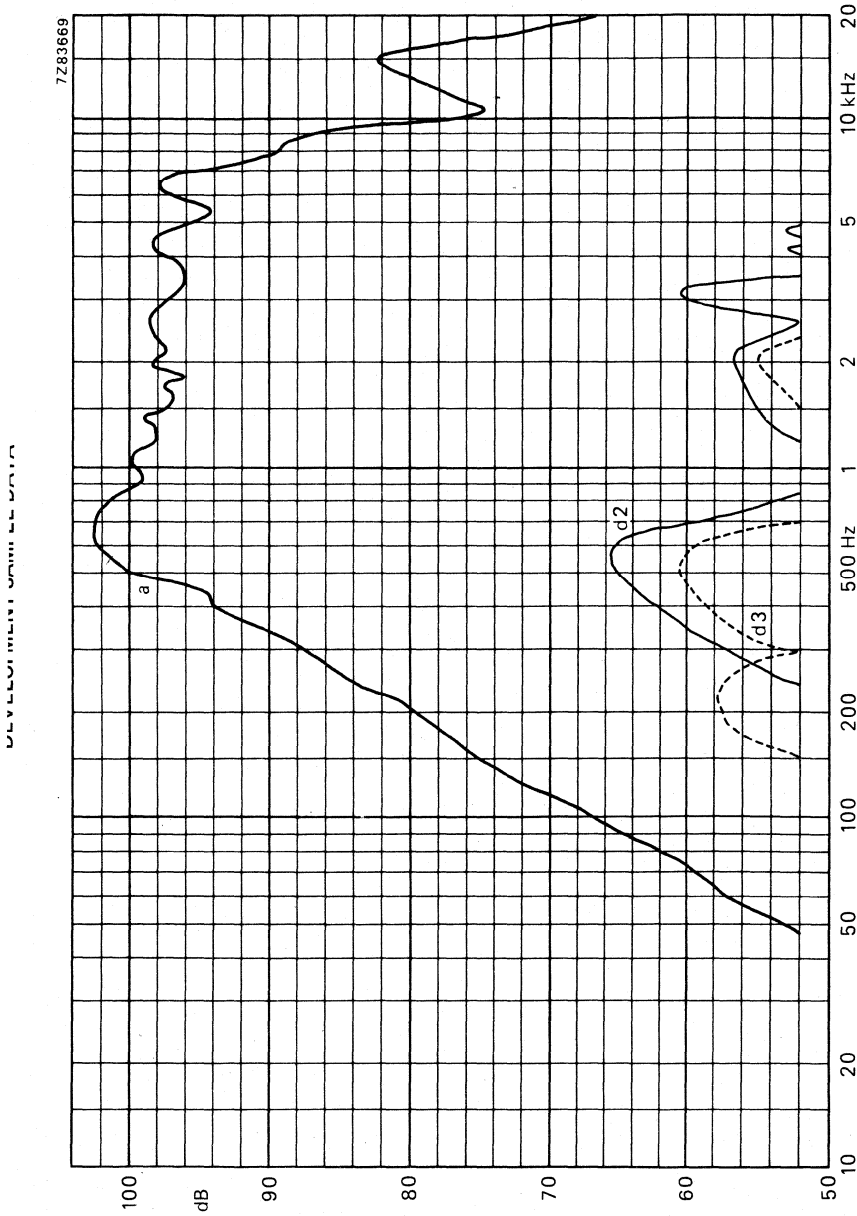

Fig. 2.



5 inch HIGH POWER SQUAWKER LOUDSPEAKER

APPLICATION

For the reproduction of audio frequencies from 1300 to 5000 Hz with very low distortion in multi-way high-fidelity loudspeaker systems in accordance with DIN45500. The loudspeaker has an excellent spherical radiation pattern.

TECHNICAL DATA

	version	
	Sq4	Sq8
Rated impedance	4	8 Ω
Voice coil resistance	3,4	7 Ω
Resonance frequency	680 Hz	
Rated frequency range	1300 to 5000 Hz	
Power handling capacity, measured with filter: 24 μ F - 0,4 mH 12 μ F - 0,8 mH loudspeaker unmounted	10	W 10 W
Operating power	4	W ←
Sweep voltage frequency range: 300 - 5000 Hz high pass filter: 24 μ F - 0,4 mH 12 μ F - 0,8 mH	3,5	V 5 V
Energy in air gap	140	mJ
Flux density	0,93	T
Air-gap height	5	mm
Voice coil height	6,8	mm
Core diameter	25	mm
Magnet material	ceramic	
diameter	72	mm
mass	0,23	kg
Mass of loudspeaker	0,8	kg

The loudspeaker has a sealed frame, a paper cone and a textile surround.

Connection to the loudspeaker by means of 2,8 mm (0,11 inch) tag connectors or by soldering.

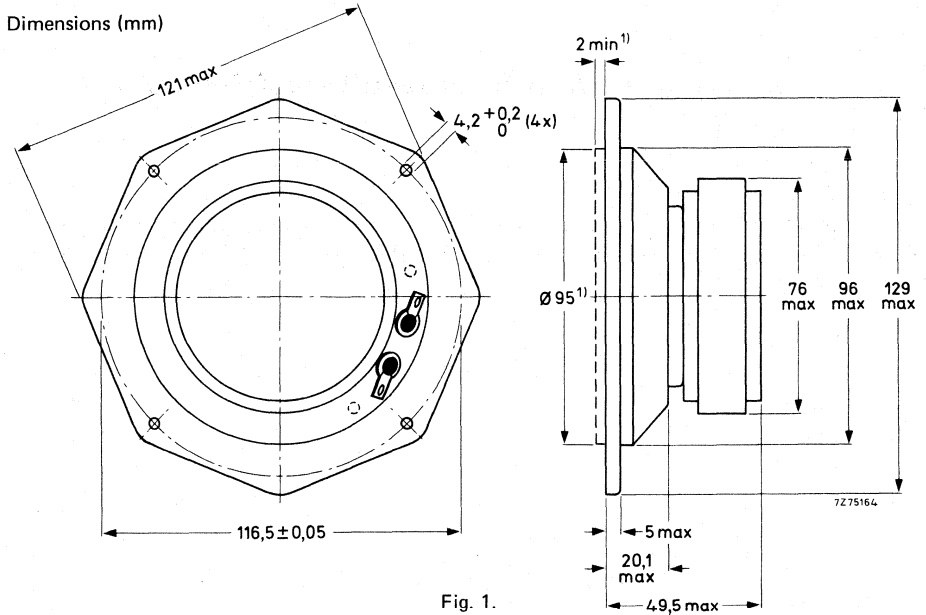

Fig. 1.

(1) Baffle hole and clearance depth required for cone movement at the specified power handling capacity. One tag is indicated by a red mark for in-phase connection.

→ **AVAILABLE VERSIONS**

AD5061/Sq4, catalogue number 2422 257 35425 } these numbers apply to bulk packed loudspeakers,
 AD5061/Sq8, catalogue number 2422 257 35426 } minimum packing quantity 24 per unit.

FREQUENCY RESPONSE CURVES (see Fig. 2)

Measured in half free field at operating power of 4 W in anechoic room, loudspeaker mounted on IEC baffle.

Curve a: Sound pressure.

Curves d2 and d3: 2nd and 3rd harmonic distortion.



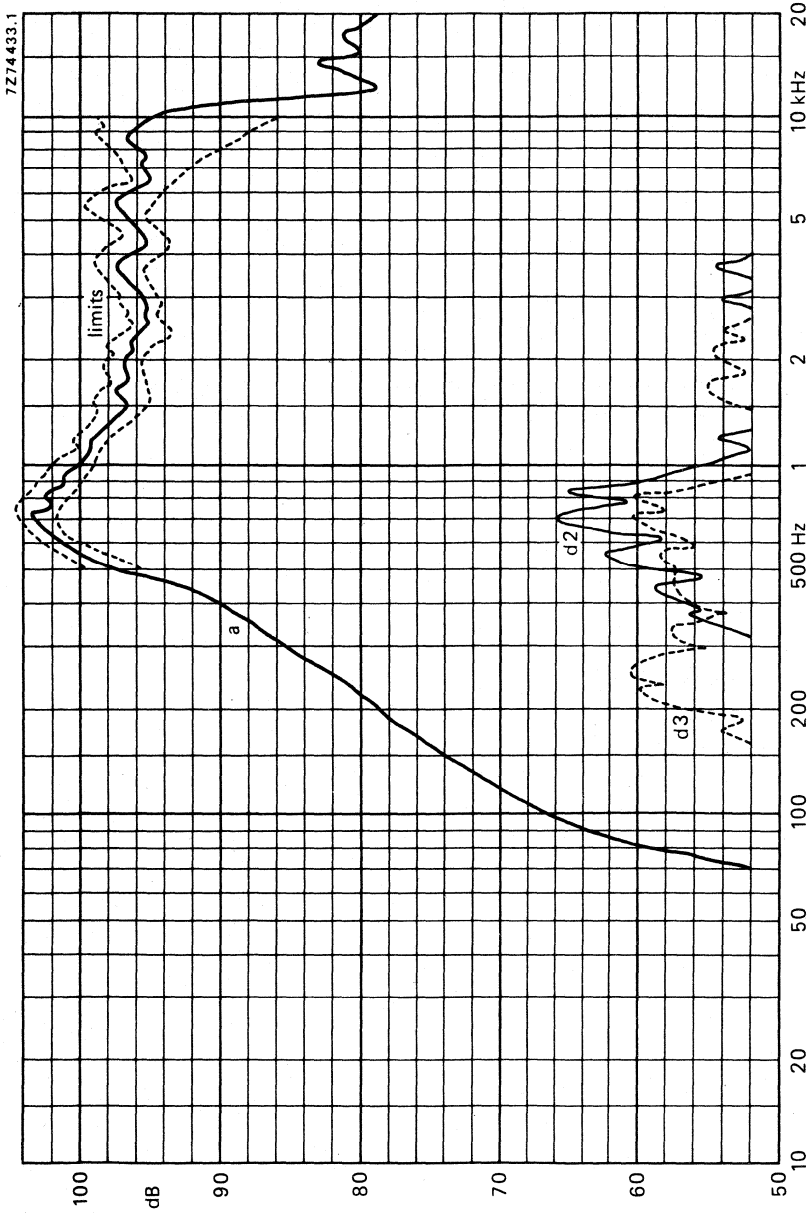

Fig. 2.



DEVELOPMENT SAMPLE DATA

This information is derived from development samples made available for evaluation. It does not form part of our data handbook system and does not necessarily imply that the device will go into production

AD5062/Sq.

5 INCH HIGH POWER SQUAWKER LOUDSPEAKER

APPLICATION

For the reproduction of audio frequencies from 400 to 5000 Hz with very low distortion in multi-way high-fidelity loudspeaker systems in accordance with DIN 45500. The loudspeaker has an excellent spherical radiation pattern.

TECHNICAL DATA

	version		
	Sq4	Sq8	
Rated impedance	4	8	Ω
Voice coil resistance	3,4	6,4	Ω
Rated frequency range	400 to 5000		Hz
Resonance frequency	220		Hz
Power handling capacity, loudspeaker unmounted of loudspeaker only	20		W
of system, measured with filter: 72 μ F - 2,1 mH	50		W
36 μ F - 4,5 mH		50	W
Operating power	4		W
Sweep voltage			
frequency range: 400 - 5000 Hz			
filter high pass : 72 μ F - 2,1 mH	3,5		V
36 μ F - 4,5 mH		5	V
Energy in air gap	140		mJ
Flux density	0,93		T
Air-gap height	5		mm
Voice coil height	6	6,6	mm
Core diameter	25		mm
Magnet material	ceramic		
diameter	73		mm
mass	0,23		kg
Mass of loudspeaker	0,8		kg

The loudspeaker has a paper cone, a textile surround and a sealed pot; no acoustic isolation required. Connection to the loudspeaker by means of 6,3 mm (0,25 inch) tag connectors or by soldering.

Dimensions in mm

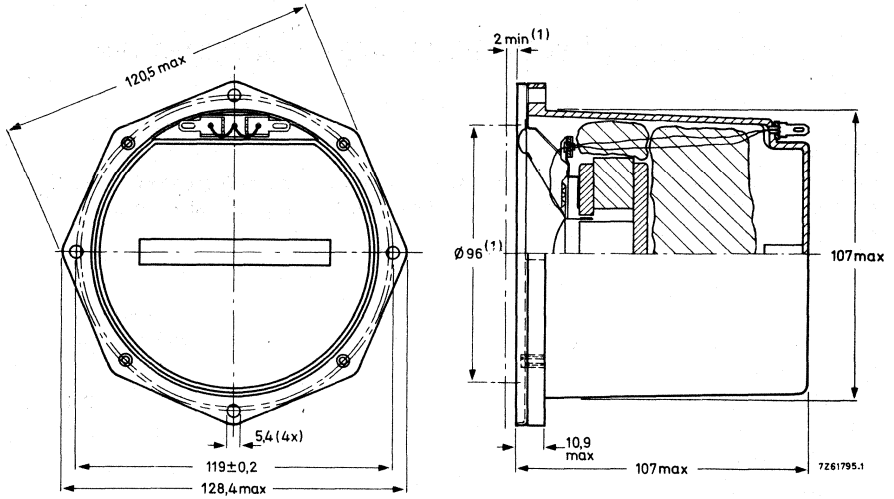

Fig. 1.

(1) Baffle hole and clearance depth required for cone movement at the specified power handling capacity.

One tag is indicated by a red mark for in-phase connection.

→ **AVAILABLE VERSIONS**

AD5062/Sq4, catalogue number 2404 257 35431 } these numbers apply to bulk packed loudspeakers,
 AD5062/Sq8, catalogue number 2404 257 35432 } minimum packing quantity 24 per unit.

FREQUENCY RESPONSE CURVES (see Fig. 2)

Measured in half free field at operating power of 4 W in anechoic room, loudspeaker mounted on IEC baffle.

Curve a: Sound pressure.

Curves d2 and d3: 2nd and 3rd harmonic distortion.

DEVELOPMENT SAMPLE DATA

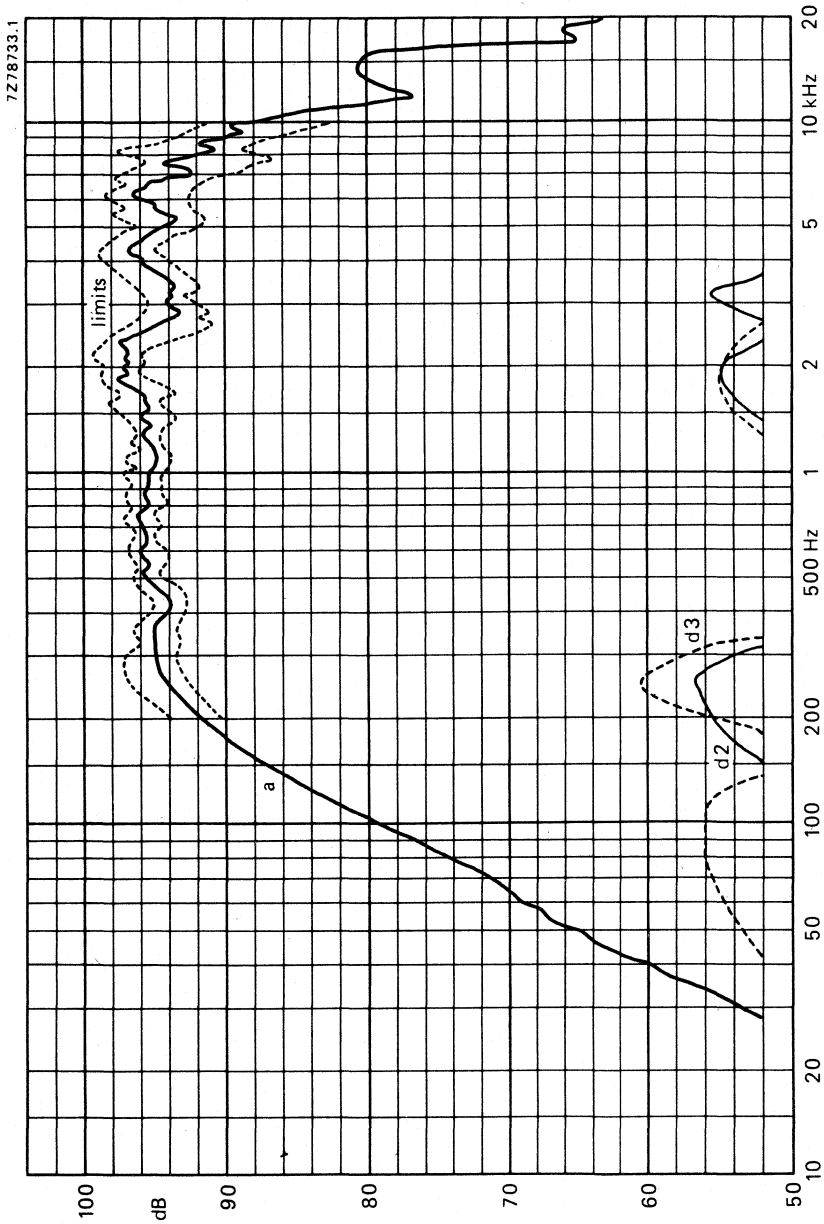

Fig. 2.



DEVELOPMENT SAMPLE DATA

This information is derived from development samples made available for evaluation. It does not necessarily imply that the device will go into regular production.

AD50800/Sq.

5 INCH HIGH POWER SQUAWKER LOUDSPEAKER

APPLICATION

For the reproduction of audio frequencies from 400 to 5000 Hz with very low distortion in multi-way high-fidelity loudspeaker systems in accordance with DIN 45500. The loudspeaker has an excellent spherical radiation pattern.

TECHNICAL DATA

	version	
	Sq4	Sq8
Rated impedance	4	8 Ω
Voice coil resistance	3,2	6,8 Ω
Rated frequency range	400 to 5000	Hz
Resonance frequency	280	Hz
Power handling capacity of system, measured with filter:		
72 μ F – 2,1 mH	15	W
36 μ F – 4,5 mH		15 W
Operating power	6	W
Sweep voltage, frequency range: 400 – 5000 Hz, high-pass filter:		
72 μ F – 2,1 mH	5	V
36 μ F – 4,5 mH		6,9 V
Energy in air gap	55	mJ
Flux density	0,93	T
Air-gap height	3	mm
Voice coil height	4,4	mm
Core diameter	18	mm
Magnet material	ceramic	
diameter	53	mm
mass	0,1	kg
Mass of loudspeaker	0,4	kg

The loudspeaker has a paper cone, a textile surround and a sealed pot; no acoustic isolation required. Two tinned 2,8 mm (0,11 inch) tag connectors permit connection to the loudspeaker by plugging or soldering.



Dimensions in mm

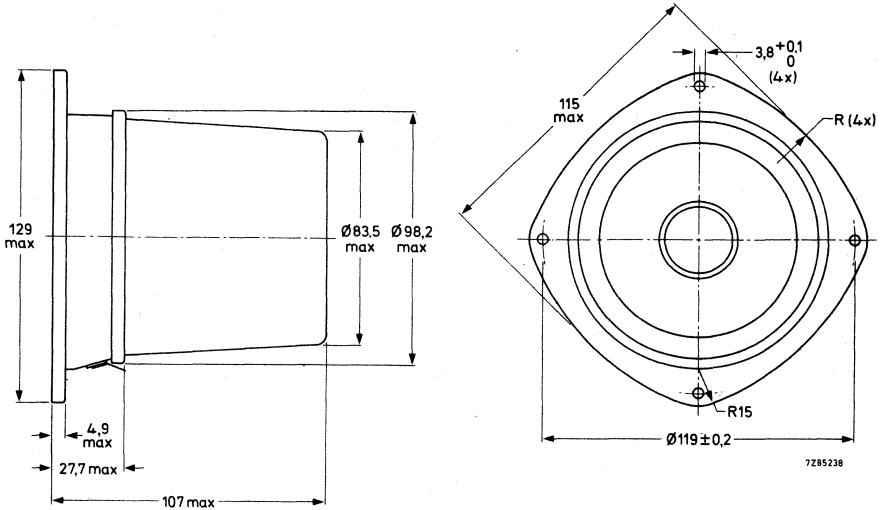

Fig. 1.

Baffle hole diameter minimum 100 mm.

One tag is indicated by a red mark for in-phase connection.

AVAILABLE VERSIONS

AD50800/Sq4, catalogue number 2422 257 45121

AD50800/Sq8, catalogue number 2422 257 45122

these numbers apply to bulk packed loudspeakers, minimum packing quantity 24 per unit.

FREQUENCY RESPONSE CURVE (See Fig. 2)

Measured in anechoic room at the operating power. Loudspeaker mounted on IEC baffle according to IEC 268-5 par. 4-4.

Curve a: Sound pressure.

Curves d2 and d3: 2nd and 3rd harmonic distortion.



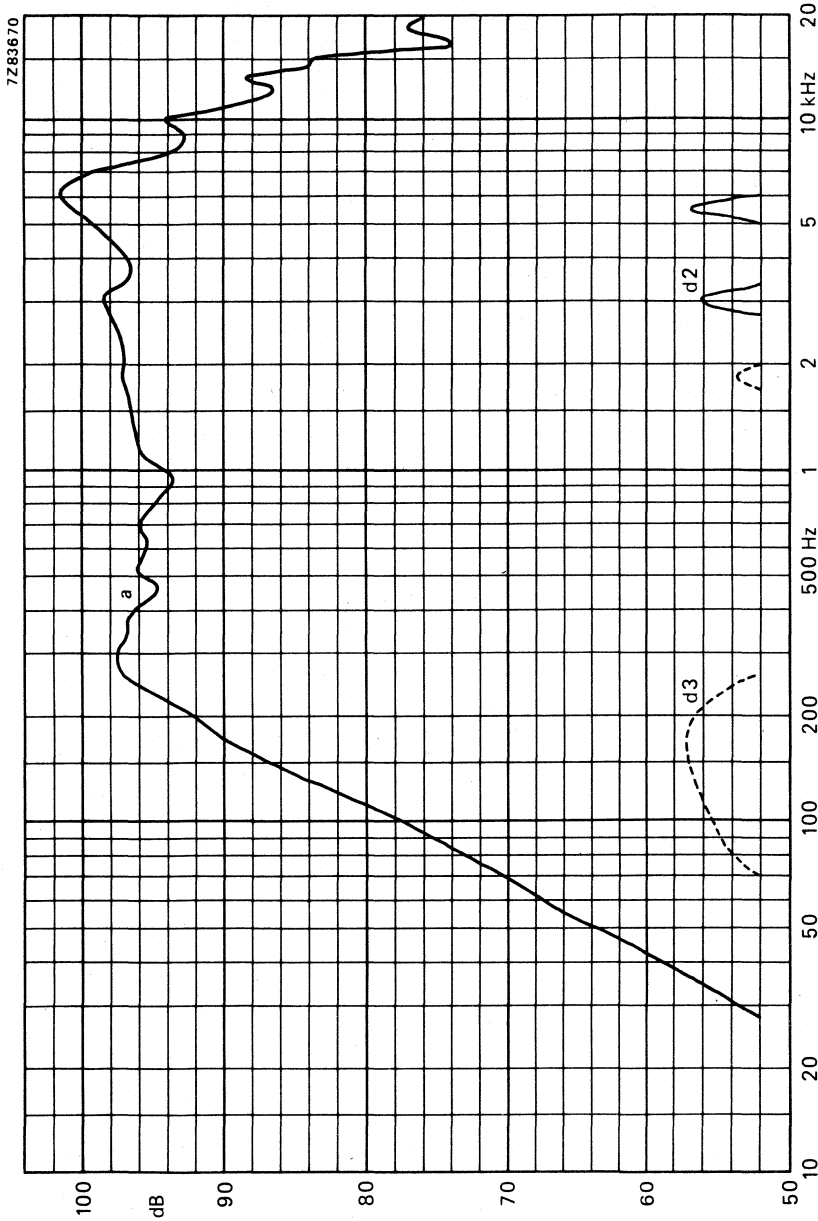

Fig. 2.



DEVELOPMENT SAMPLE DATA

This information is derived from development samples made available for evaluation. It does not necessarily imply that the device will go into regular production.

AD50801/Sq.

5 INCH HIGH POWER SQUAWKER LOUDSPEAKER

APPLICATION

For the reproduction of audio frequencies from 1300 to 5000 Hz with very low distortion in multi-way high-fidelity loudspeaker systems in accordance with DIN 45500. The loudspeaker has an excellent spherical radiation pattern.

TECHNICAL DATA

	version	
	Sq4	Sq8
Rated impedance	4	8 Ω
Voice coil resistance	3,2	6,8 Ω
Rated frequency range	1300 to 5000	Hz
Resonance frequency	650	Hz
Power handling capacity, measured with filter:		
24 μ F – 0,4 mH	15	W
12 μ F – 0,8 mH		15 W
Operating power	6	W
Sweep voltage, frequency range: 400 – 5000 Hz, high-pass filter:		
24 μ F – 0,4 mH	5	V
12 μ F – 0,8 mH		6,9 V
Energy in air gap	55	mJ
Flux density	0,93	T
Air-gap height	3	mm
Voice coil height	4,2	mm
Core diameter	18	mm
Magnet material	ceramic	
diameter	53	mm
mass	0,1	kg
Mass of loudspeaker	0,3	kg

The loudspeaker has a paper cone, a textile surround; no acoustic isolation required. Two tinned 2,8 mm (0,11 inch) tag connectors permit connection to the loudspeaker by plugging or soldering.

Dimensions in mm

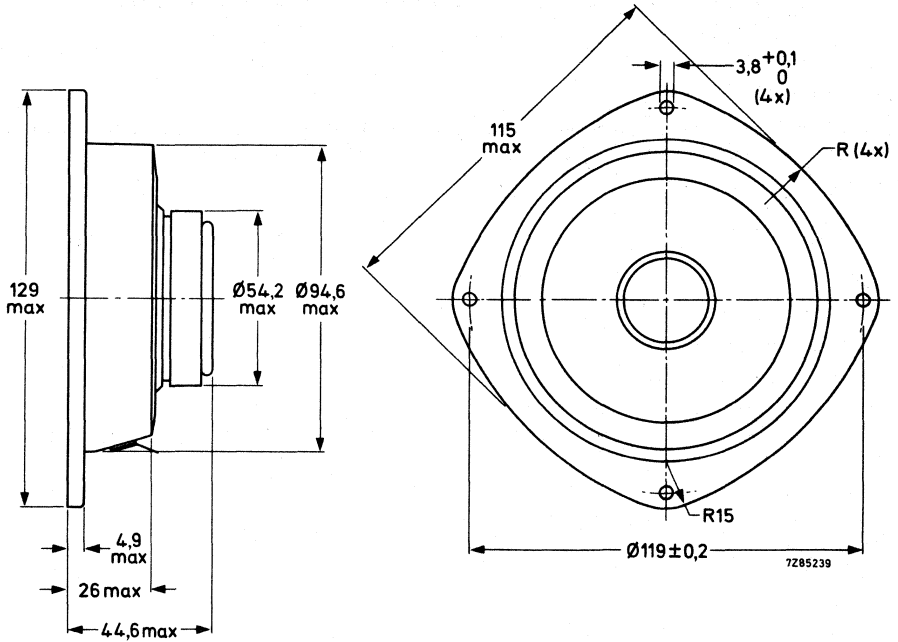

Fig. 1.

Baffle hole diameter minimum 100 mm.

One tag is indicated by a red mark for in-phase connection.

AVAILABLE VERSIONS

AD50801/Sq4, catalogue number 2422 257 45131
 AD50801/Sq8, catalogue number 2422 257 45132

these numbers apply to bulk packed loudspeakers, minimum packing quantity 24 per unit.

FREQUENCY RESPONSE CURVE (See Fig. 2)

Measured in anechoic room at the operating power. Loudspeaker mounted on IEC baffle according to IEC 268-5 par. 4.4.

Curve a: Sound pressure.

Curves d2 and d3: 2nd and 3rd harmonic distortion.



DEVELOPMENT SAMPLE DATA

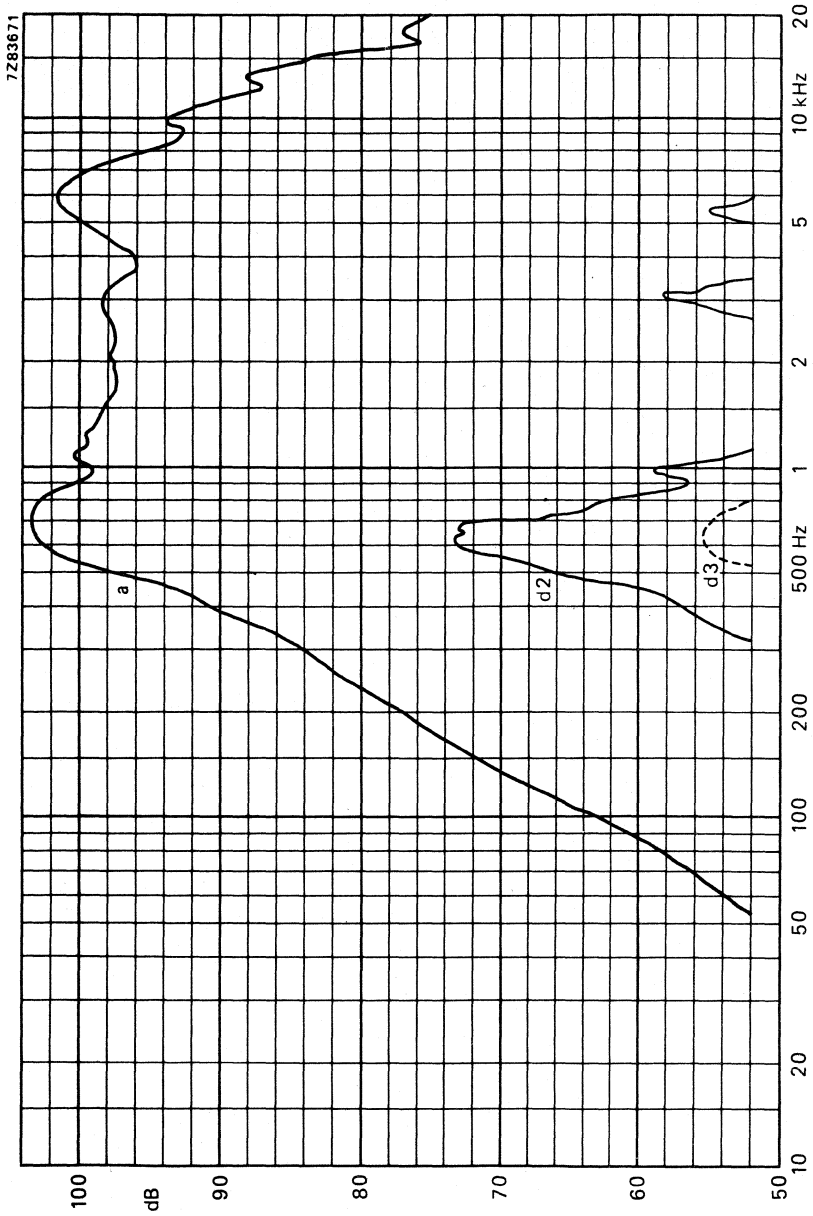

Fig. 2.





HIGH POWER WOOFER LOUDSPEAKERS



771128-12-01

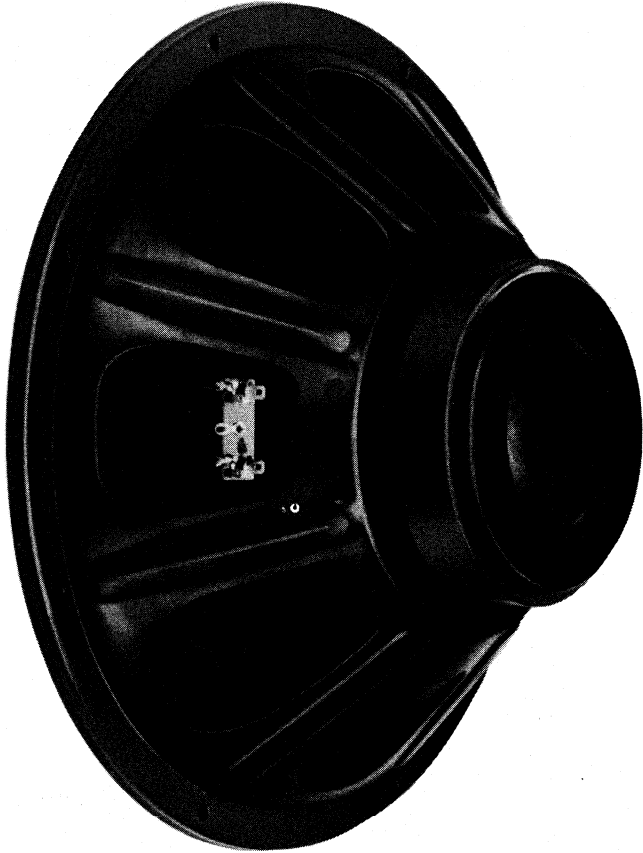

Type AD12200/W8



4 INCH HIGH POWER WOOFER LOUDSPEAKER

APPLICATION

The absence of stray field due to its screened and compensated ceramic magnet system makes this loudspeaker very suitable for use in television sets. It can be used in sealed acoustic enclosures and in bass reflex enclosures of maximum 7 litres.

TECHNICAL DATA

	version	
	W4	W8
Rated impedance	4	8 Ω
Voice coil resistance	3,2	7 Ω
Rated frequency range	35 to 2000 Hz	
Resonance frequency	60 Hz	
Power handling capacity measured without filter, mounted in 7 l bass reflex enclosure	15 W	
Operating power	8 W	
Sweep voltage, frequency range: 30 to 6000 Hz	5,5	7,75 V
Stray field, distance 70 mm (DIN 45578-2-2-5)	max.	3,5 G
Energy in air gap	100 mJ	
Flux density	0,85 T	
Air-gap height	5 mm	
Voice coil height	6 mm	
Core diameter	25 mm	
Magnet material	ceramic ←	
diameter	25 mm	
mass	0,06 kg	
Mass of loudspeaker	0,42 kg	

The loudspeaker has a paper cone, a rubber surround and a sealing strip at the rear of the gasket. Connection to the loudspeaker by means of 2,8 mm (0,11 inch) tag connectors or by soldering.



Dimensions in mm

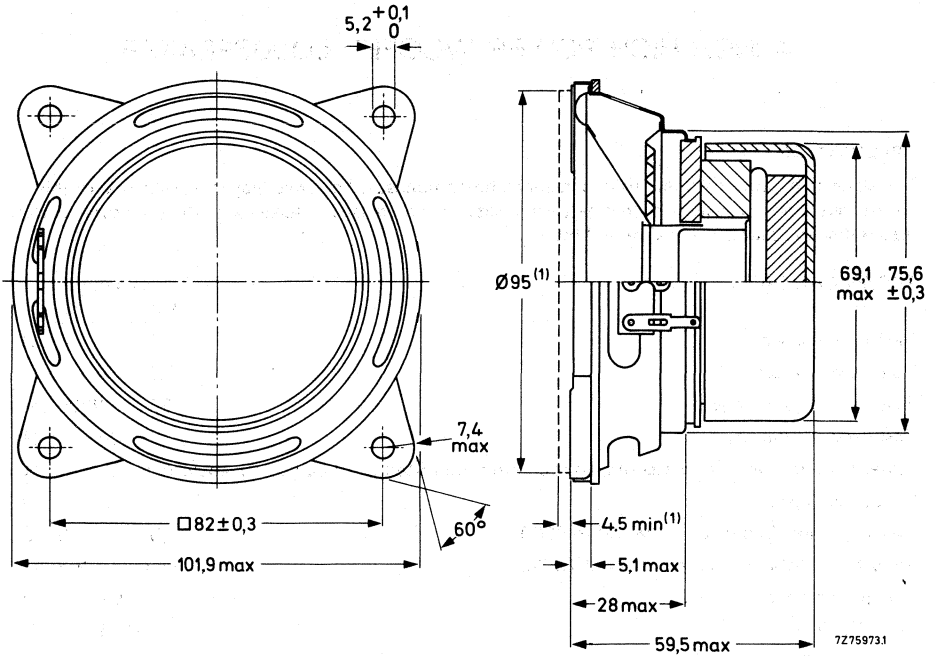

Fig. 1.

(1) Baffle hole and clearance depth required for cone movement at the specified power handling capacity.

One tag is indicated by a red mark for in-phase connection.

→ AVAILABLE VERSIONS

AD40500/W4, catalogue number 2422 257 34721
 AD40500/W8, catalogue number 2422 257 34722

these numbers apply to bulk packed loudspeakers, minimum packing quantity 16 per unit.

FREQUENCY RESPONSE CURVES (See Fig. 2)

Measured in anechoic room at the operating power. Loudspeaker mounted in 7 l bass reflex enclosure.

Curve a: Sound pressure.

Curves d2 and d3: 2nd and 3rd harmonic distortion.

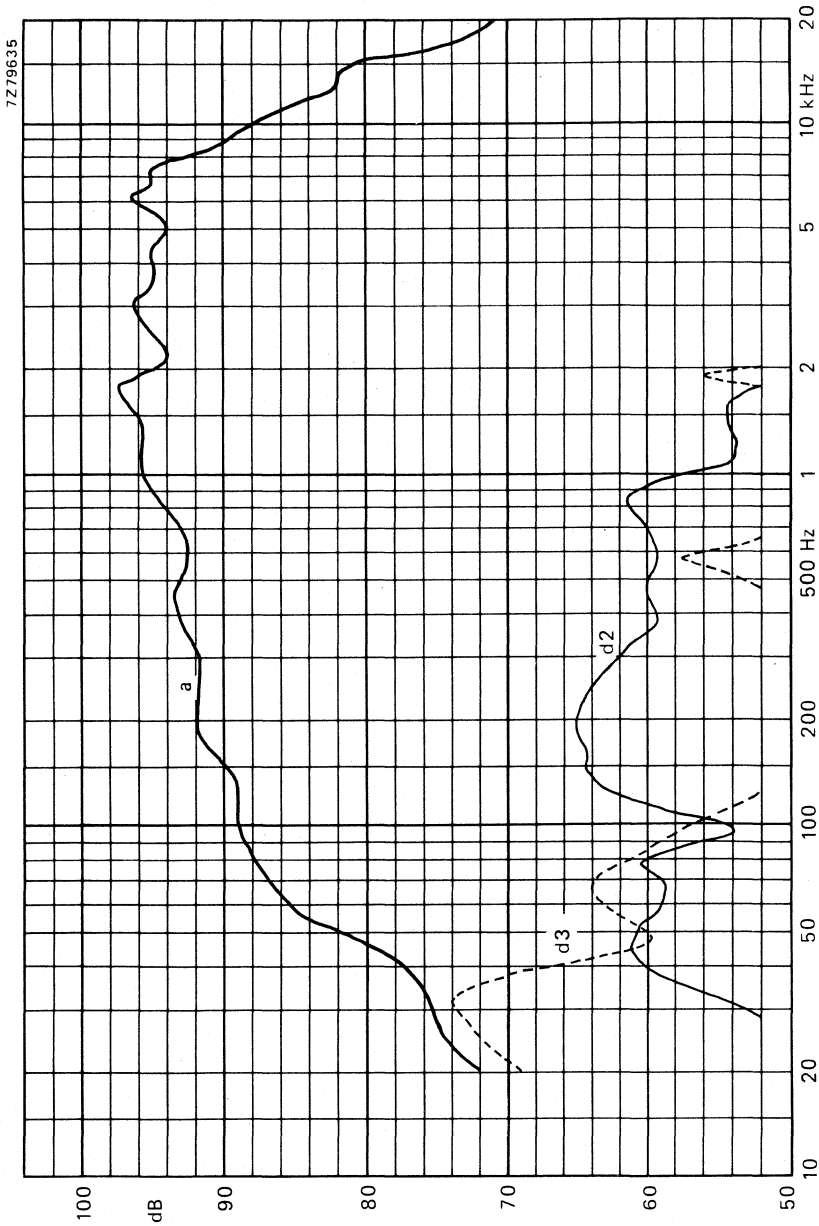

Fig. 2.



DEVELOPMENT SAMPLE DATA

This information is derived from development samples made available for evaluation. It does not necessarily imply that the device will go into regular production.

AD40501/W.

4 INCH HIGH POWER WOOFER LOUDSPEAKER

APPLICATION

For high-fidelity bass reproduction in bass reflex enclosures specially for video applications. Recommended volume of enclosure 7 litres. The loudspeaker has a very low distortion, and a very low stray magnetic field.

TECHNICAL DATA

	version	
	W4	W8
Rated impedance	4	8 Ω
Voice coil resistance	3,2	7 Ω
Rated frequency range	70 to 10 000	Hz
Resonance frequency	72	Hz
Power handling capacity, mounted in 7 l bass reflex enclosure, measured without filter	20	W
Maximum power on loudspeaker	30	W
Operating power	7	8 W
Sweep voltage, frequency range: 30 to 6000 Hz	5,5	7,75 V
Energy in air gap	154	mJ
Flux density	0,96	T
Stray magnetic field according to DIN 45578 par. 2.2.5, distance 70 mm	0,35	T
Air-gap height	5	mm
Voice coil height	6	6,6 mm
Core diameter	25	mm
Magnet material	ceramic	
diameter	60	mm
mass	0,225	kg
Mass of loudspeaker	0,68	kg

The loudspeaker has a paper cone and a rubber surround. Two tinned 2,8 mm (0,11 inch) tag connectors permit connection to the woofer by plugging or soldering.



Dimensions in mm

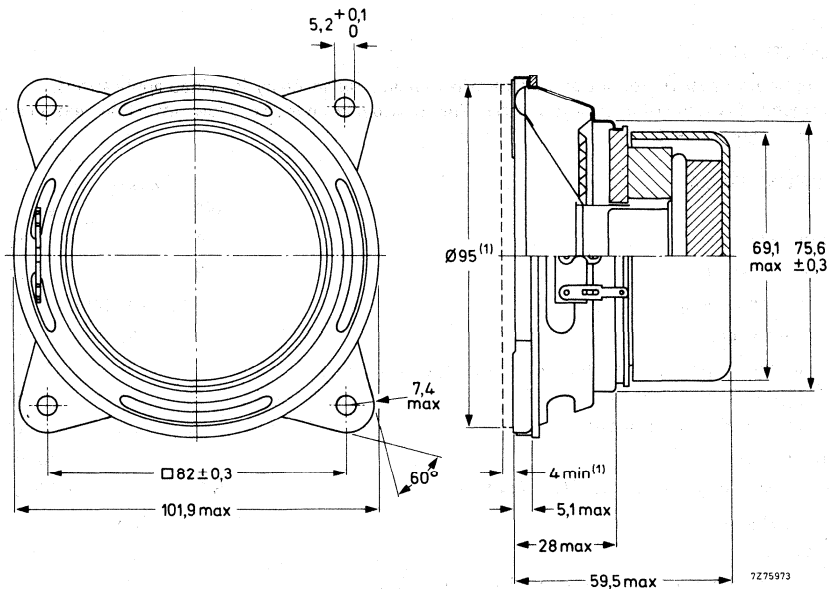

Fig. 1.

(1) Baffle hole and clearance depth required for cone movement at the specified power handling capacity.

One tag is indicated by a red mark for in-phase connection.

AVAILABLE VERSIONS

- AD40501/W4, catalogue number 2422 257 34723
- AD40501/W8, catalogue number 2422 257 34724

these numbers apply to bulk packed loudspeakers, minimum packing quantity 16 per unit.

FREQUENCY RESPONSE CURVES (See Fig. 2)

Measured in anechoic room at the operating power. Loudspeaker mounted on IEC baffle according to IEC 268-5 par. 4-4.

Curve a: Sound pressure.

Curves d2 and d3: 2nd and 3rd harmonic distortion.

DEVELOPMENT SAMPLE DATA

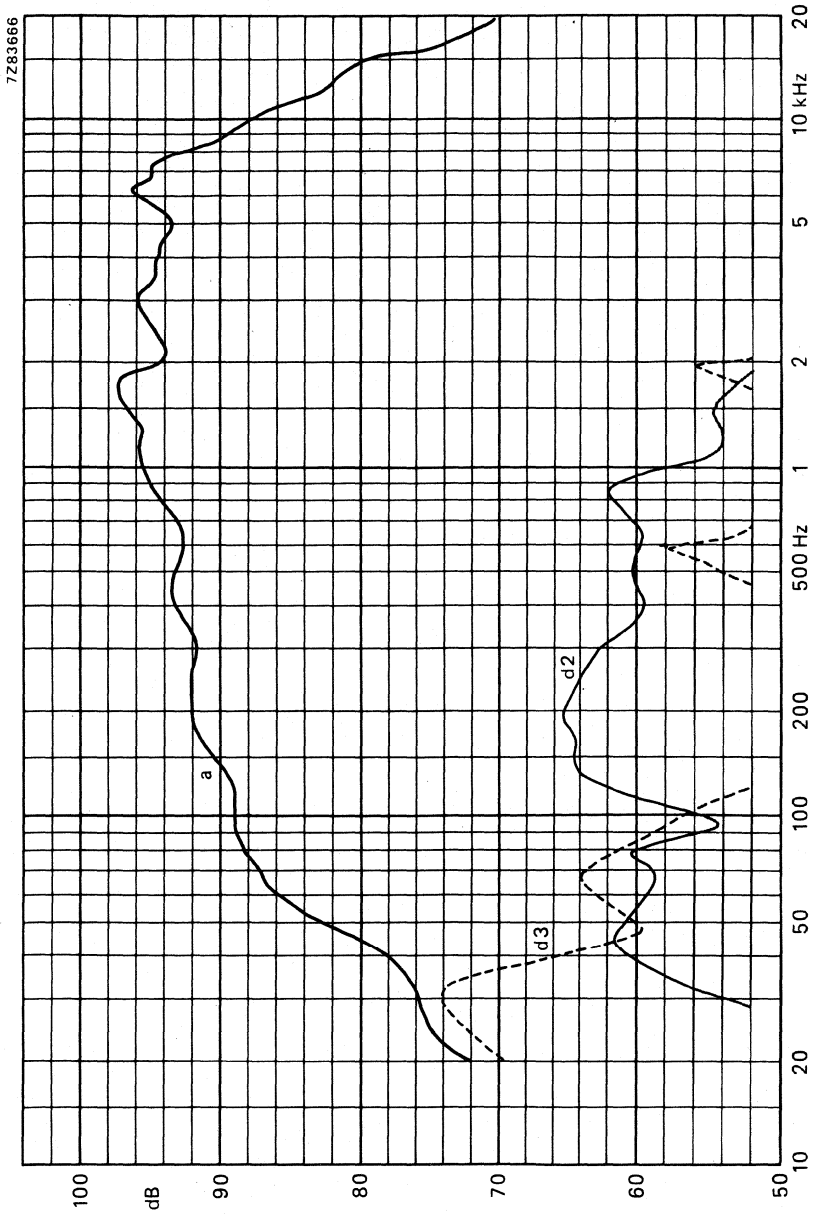

Fig. 2.



4 INCH HIGH POWER WOOFER LOUDSPEAKER

APPLICATION

For use in bass reflex enclosures of maximum 5 litres.

TECHNICAL DATA

	version	
	W4	W8
Rated impedance	4	8 Ω
Voice coil resistance	3,8	6,7 Ω
Rated frequency range	50 to 11 000 Hz	
Resonance frequency	68 Hz	
Power handling capacity measured without filter, mounted in 2 l sealed enclosure	30	W
mounted in 5 l bass reflex enclosure	15	W
Operating power	12 W	
Sweep voltage, frequency range: 50 to 20 000 Hz	5,5	7,7 V
Energy in air gap	140	mJ
Flux density	0,93	T
Air-gap height	5	mm
Voice coil height	10	mm
Core diameter	25	mm
Magnet material	ceramic	
diameter	72	mm
mass	0,26	kg
Mass of loudspeaker	0,62	kg

The loudspeaker has a paper cone, a rubber surround, and a sealing strip at the rear of the gasket. Connection to the loudspeaker by means of 2,8 mm (0,11 inch) tag connectors or by soldering.



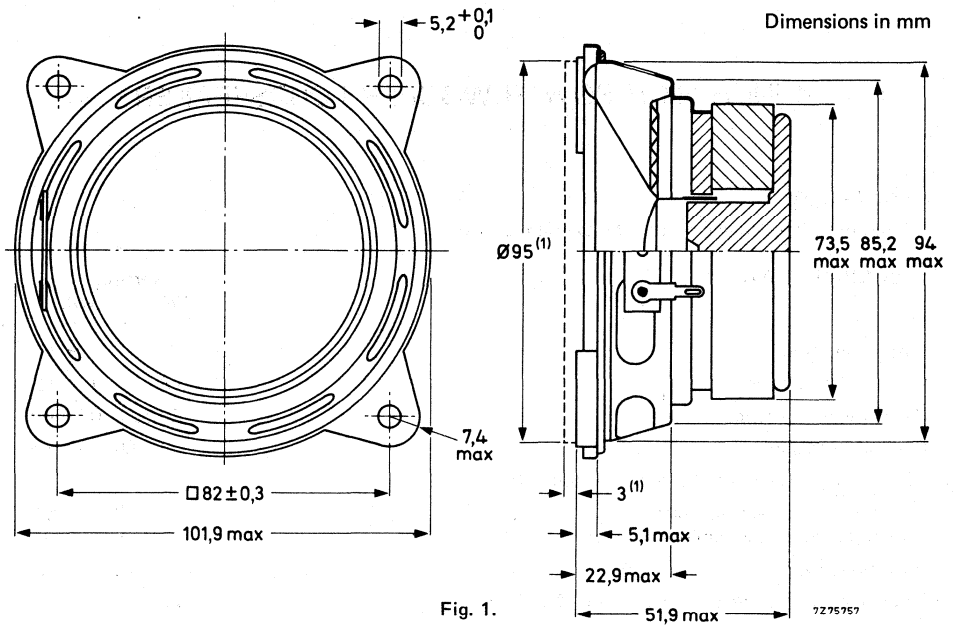

(1) Baffle hole and clearance depth required for cone movement at the specified power handling capacity.

One tag is indicated by a red mark for in-phase connection.

→ AVAILABLE VERSIONS

AD4060/W4, catalogue number 2422 257 34621
 AD4060/W8, catalogue number 2422 257 34622

these numbers apply to bulk packed loudspeakers, minimum packing quantity 32 per unit.

FREQUENCY RESPONSE CURVES (See Fig. 2)

Measured in anechoic room at the operating power. Loudspeaker mounted on IEC baffle acc. to IEC 268-5 par. 4-4.

Curve a: Sound pressure.

Curves d2 and d3: 2nd and 3rd harmonic distortion.



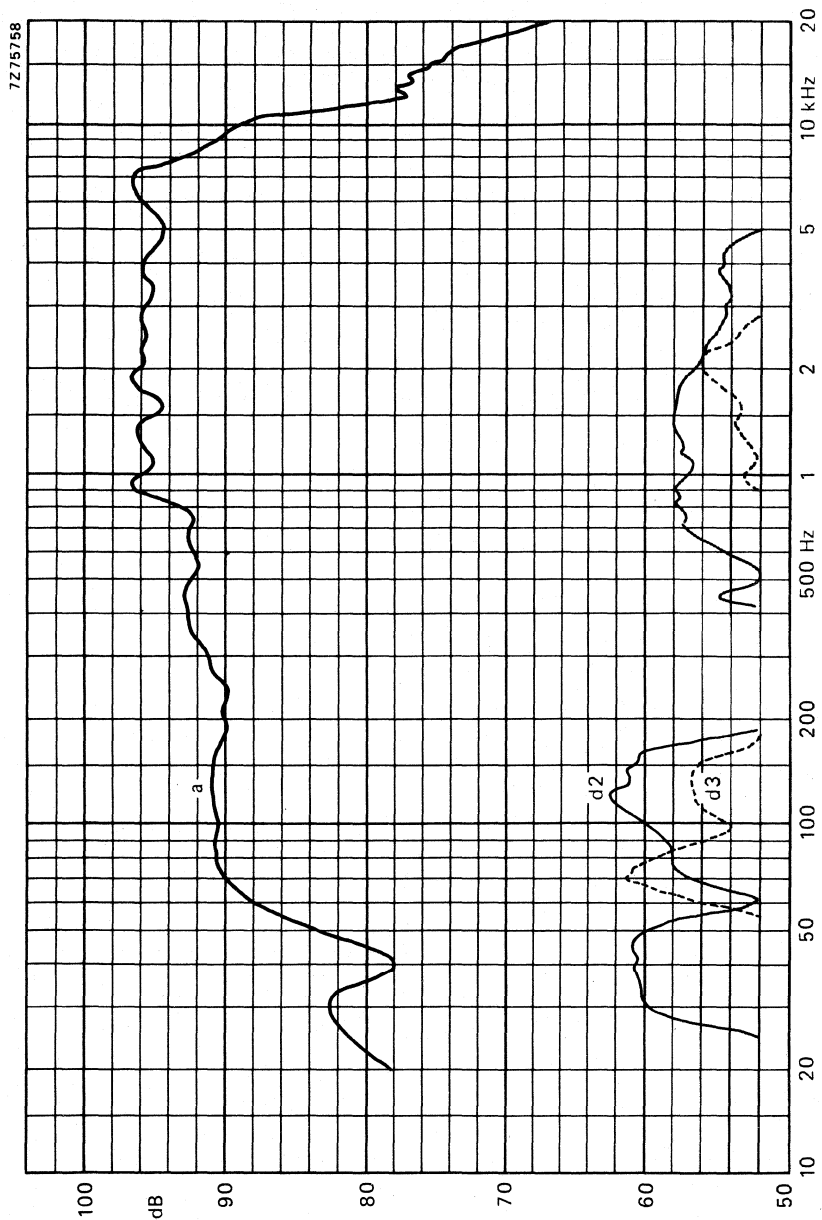

Fig. 2.



DEVELOPMENT SAMPLE DATA

This information is derived from development samples made available for evaluation. It does not necessarily imply that the device will go into regular production.

AD40900/W.

4 INCH HIGH POWER WOOFER LOUDSPEAKERS

APPLICATION

For high-fidelity bass reproduction in bass reflex enclosure. Recommended volume of enclosure 3 litres. The loudspeaker has a very low distortion. The magnet has a screened and compensated ceramic system.

TECHNICAL DATA

	version	
	W4	W8
Rated impedance	4	8 Ω
Voice coil resistance	3,2	7 Ω
Rated frequency range	60 to 15 000 Hz	
Resonance frequency	70	Hz
Power handling capacity, mounted in 3 l sealed enclosure, measured without filter	15	W
Maximum power on loudspeaker	25	W
Operating power	1,56	2,42 W
Sweep voltage, frequency range: 35 to 20 000 Hz	4	V
Maximum excursion voltage at 20 Hz	to be established	
Energy in air gap	65	mJ
Flux density	1,045	T
Force factor (B x l) at 1 A	to be established	
Total moving mass	to be established	
Compliance, loudspeaker unmounted	to be established	
Quality factor	to be established	
mechanical	to be established	
electrical	to be established	
total	to be established	
Air-gap height	3	mm
Voice coil height	4,5	mm
Core diameter	18	mm
Magnet material	ceramic	
diameter	45	mm
mass	1,02	kg
Mass of loudspeaker	0,35	kg

The loudspeaker has a paper cone and a foam rubber surround. Two tinned 2,8 mm (0,11 inch) tag connectors permit connection to the woofer by plugging or soldering. ←



Dimensions in mm

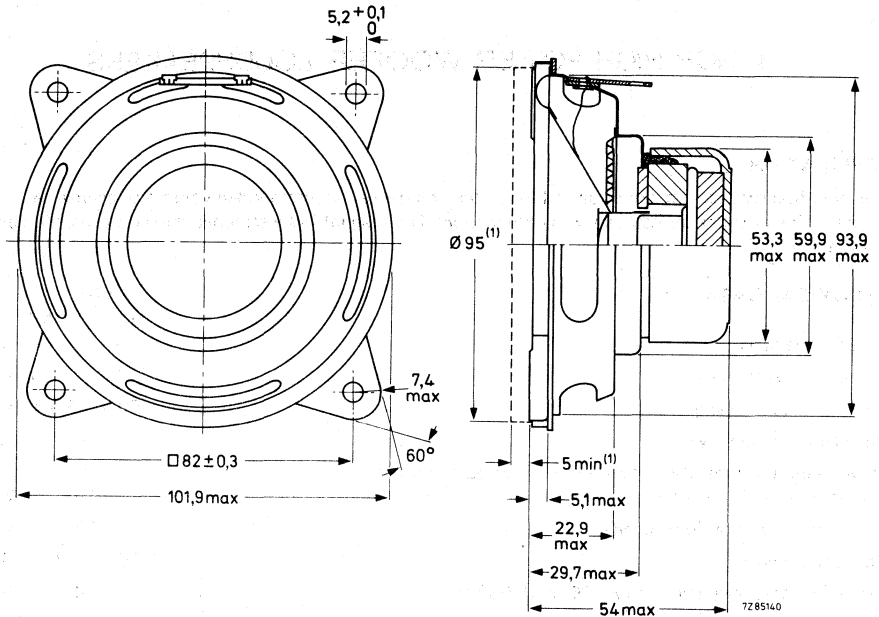

Fig. 1.

(1) Baffle hole and clearance depth required for cone movement at the specified power handling capacity.

One tag is indicated by a red mark for in-phase connection.

→ AVAILABLE VERSIONS

- AD40900/W4, catalogue number 2422 257 34821
- AD40900/W8, catalogue number 2422 257 34822

these numbers apply to bulk packed loudspeakers, minimum packing quantity 27 per unit.

FREQUENCY RESPONSE CURVES (See Fig. 2)

Measured in anechoic room at the operating power. Loudspeaker mounted on IEC baffle acc. to IEC 268-5 par. 4-4.

Curve a: Sound pressure.

Curves d2 and d3: 2nd and 3rd harmonic distortion.

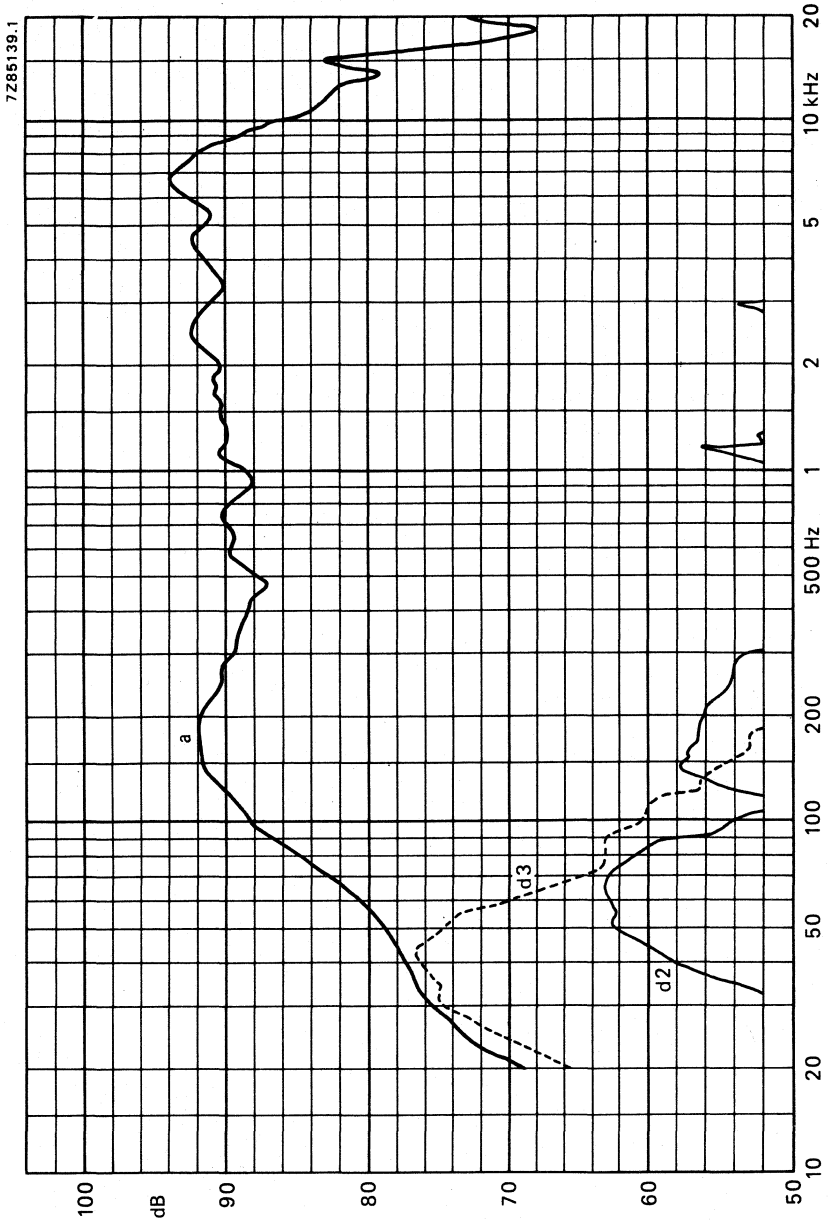

Fig. 2.



DEVELOPMENT SAMPLE DATA

This information is derived from development samples made available for evaluation. It does not necessarily imply that the device will go into regular production.

AD40910/W4.

4 INCH HIGH POWER WOOFER LOUDSPEAKER

APPLICATION

For high-fidelity bass reproduction in sealed acoustic enclosure. Recommended volume of enclosure 7 litres. The loudspeaker has a very low distortion.

TECHNICAL DATA

Rated impedance	4 Ω
Voice coil resistance	3,2 Ω
Rated frequency range	30 to 13 000 Hz
Resonance frequency	72 Hz
Power handling capacity, mounted in 7 l sealed enclosure, measured without filter	12 W
Maximum power on loudspeaker	18 W
Operating power	3,61 W
Sweep voltage, frequency range: 35 to 20 000 Hz	4,9 V
Maximum excursion voltage at 20 Hz	to be established
Energy in air gap	65 mJ
Flux density	1,045 T
Force factor (B x l) at 1 A	to be established
Total moving mass	to be established
Compliance, loudspeaker unmounted	to be established
Quality factor	
mechanical	to be established
electrical	to be established
total	to be established
Air-gap length	to be established
Air-gap height	3 mm
Voice coil height	4,2 mm
Core diameter	18 mm
Magnet material	ceramic
diameter	45 mm
mass	0,102 kg
Mass of loudspeaker	0,350 kg

The loudspeaker has a paper cone and a foam rubber surround. Two tinned 2,8 mm (0,11 inch) tag connectors permit connection to the woofer by plugging or soldering. ←

Dimensions in mm

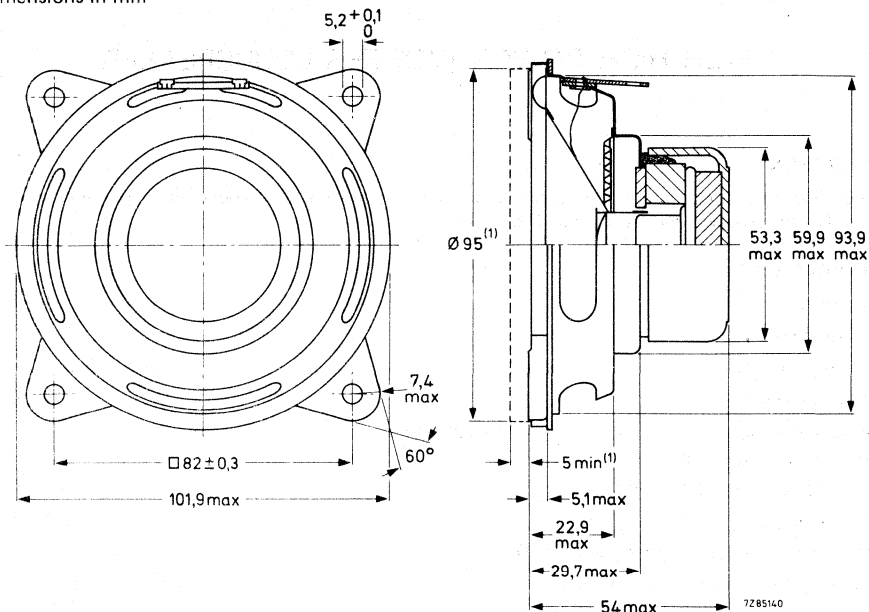

Fig. 1.

(1) Baffle-hole and clearance depth required for cone movement at the specified power handling' capacity.

One tag is indicated by a red mark for in-phase connection.

→ AVAILABLE VERSIONS

AD70601/W4, catalogue number 2422 257 34825

{ this number applies to bulk packed loudspeakers, minimum packing quantity 27 per unit.

FREQUENCY RESPONSE CURVES (See Fig. 2)

Measured in anechoic room at the operating power. Loudspeaker mounted on IEC baffle acc. to IEC 268-5 par 4-4.

Curve a: Sound pressure.

Curves d2 and d3: 2nd and 3rd harmonic distortion.



DEVELOPMENT SAMPLE DATA

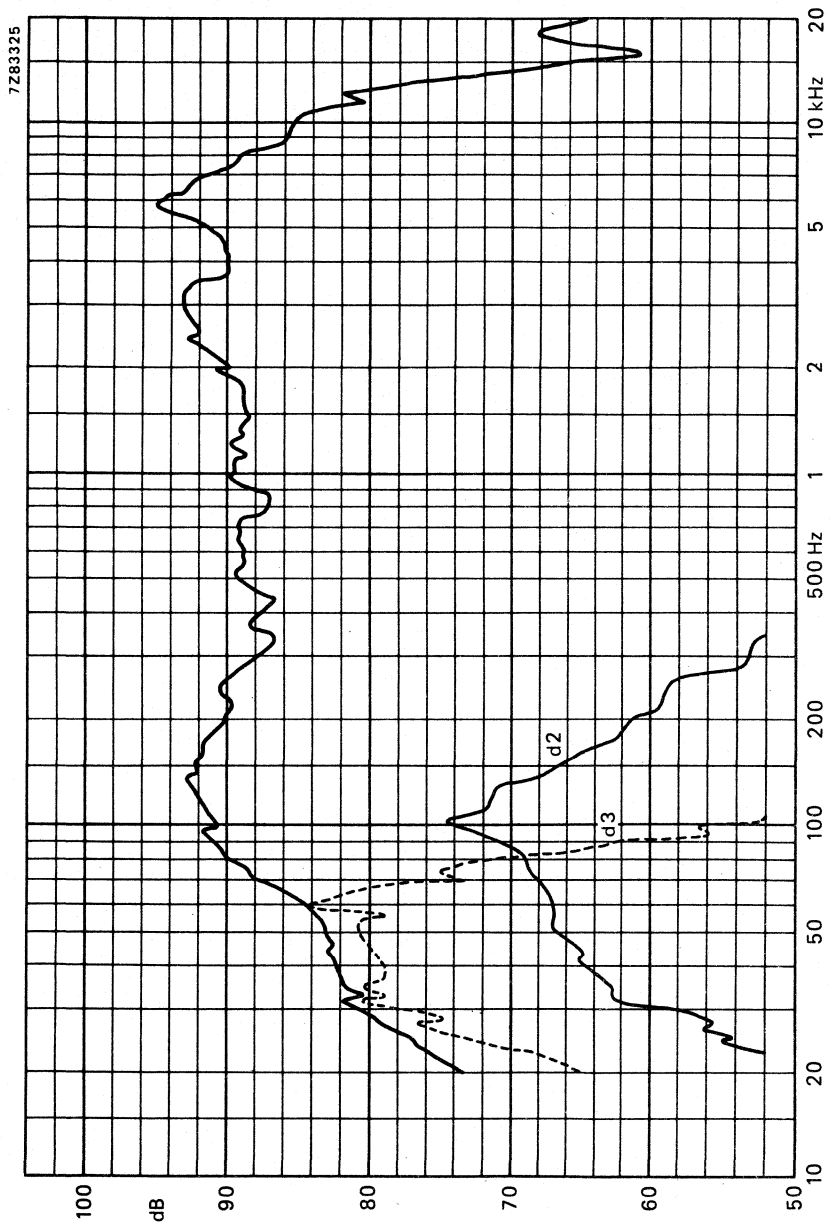

Fig. 2.



5 INCH HIGH POWER WOOFER LOUDSPEAKER

APPLICATION

For high quality reproduction in sealed acoustic enclosures. Maximum enclosure volume 3 litres.
Maximum recommended cross-over frequency 5000 Hz.

TECHNICAL DATA

	version	
	W4	W8
Rated impedance	4	8 Ω
Voice coil resistance	3,4	7 Ω
Rated frequency range	75 to 13 000 Hz	
Resonance frequency	60 Hz	
Power handling capacity, mounted in 3 l sealed enclosure	10 W	
Operating power for 90 dB sound level	2 W	
Sweep voltage, frequency range: 40 to 4000 Hz	2,8	4,2 V
Energy in air gap	140	mJ
Flux density	0,93	T
Air-gap height	5	mm
Voice coil height	6,8	mm
Core diameter	25	mm
Magnet material	ceramic	
diameter	72	mm
mass	0,23	kg
Mass of loudspeaker	0,7	kg

The loudspeaker has a paper cone and a rubber surround. Connection to the loudspeaker by means of 2,8 mm (0,11 inch) tag connectors or by soldering.



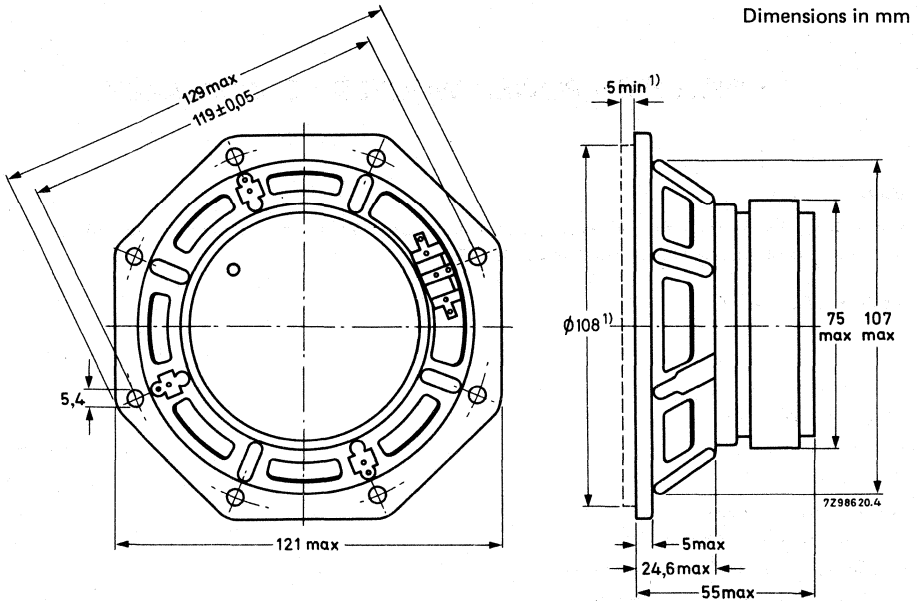

Fig. 1.

(1) Baffle hole and clearance depth required for cone movement at the specified power handling capacity.

One tag is indicated by a red mark for in-phase connection.

→ AVAILABLE VERSIONS

AD5060/W4, catalogue number 2422 257 35321
 AD5060/W8, catalogue number 2422 257 35322

these numbers apply to bulk packed loudspeakers, minimum packing quantity 18 per unit.

FREQUENCY RESPONSE CURVES (See Fig. 2)

Measured in anechoic room at the operating power. Loudspeaker mounted in sealed 3 l enclosure, filled with 0,5 kg of glass wool.

Curve a: Sound pressure.

Curves d2 and d3: 2nd and 3rd harmonic distortion.



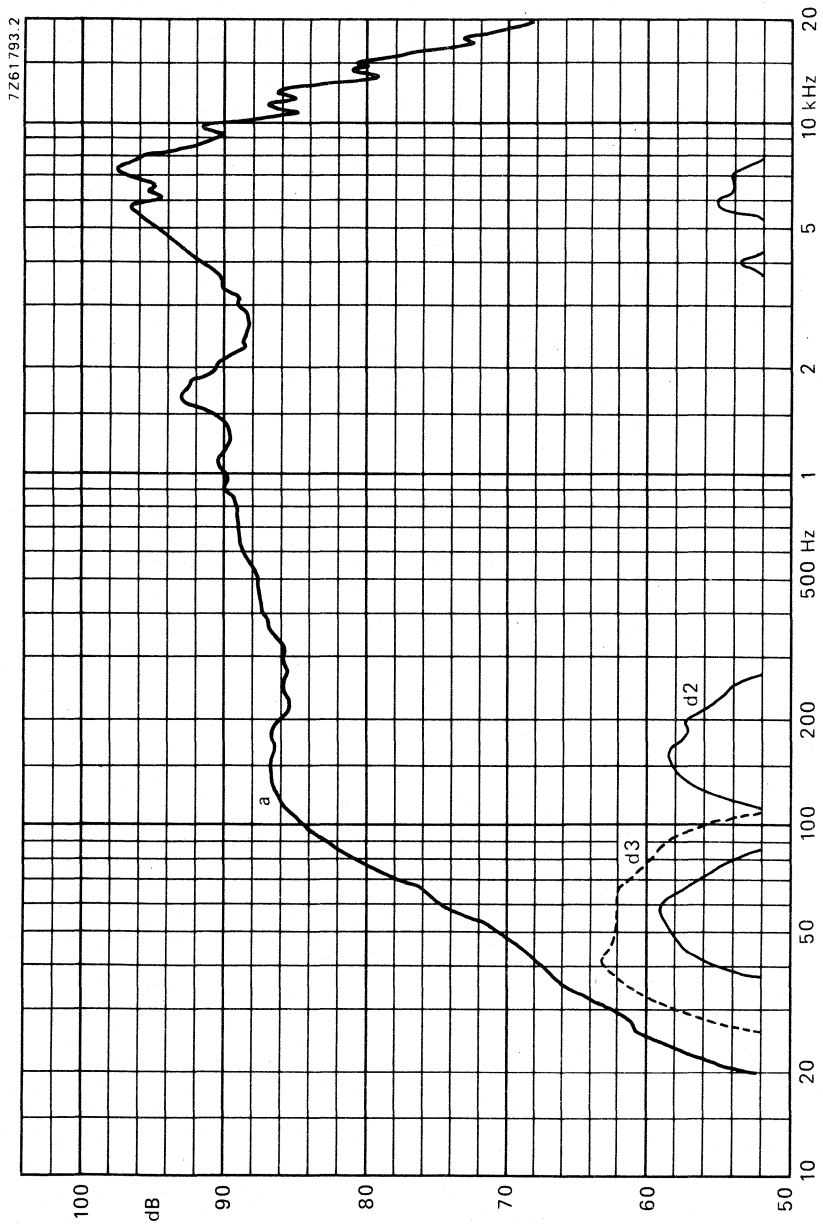

Fig. 2.



7 INCH HIGH POWER WOOFER LOUDSPEAKERS

APPLICATION

For high-fidelity bass reproduction in sealed acoustic enclosure. Recommended volume of enclosure 15 litres. The loudspeaker has a very low distortion.

TECHNICAL DATA

	version	
	W4	W8
Rated impedance	4	8 Ω
Voice coil resistance	3,8	7,5 Ω
Rated frequency range	50 to 5000	Hz
Resonance frequency	42	Hz
Power handling capacity, mounted in 80 l sealed enclosure, measured without filter	30	W
Maximum power on loudspeaker	60	W
Operating power	12,5	W
Sweep voltage, frequency range: 35 to 5000 Hz	5,5	7 V
Maximum excursion voltage at 20 Hz	8,5	13 V
Energy in air gap	135	140 mJ
Flux density	0,87	0,93 T
Force factor (B x l) at 1 A	4	5,5 Wb/m
Total moving mass	13,2	g
Compliance, loudspeaker unmounted	1,2	mm/N
Quality factor		
mechanical	4,57	4,33
electrical	1,26	1,33
total	0,99	1,02
Air-gap length	1,2	1 mm
Air-gap height	5	mm
Voice coil height	10	mm
Core diameter	25	mm
Magnet material	ceramic	
diameter	72	mm
mass	0,24	kg
Mass of loudspeaker	0,65	kg

Type AD70601/W. has a rubber surround, type AD70602/W. has a polyester surround (being the only difference between the two types). Connection to the loudspeakers by means of 6,3 mm (0,25 inch) tag connectors or by soldering.

Dimensions in mm

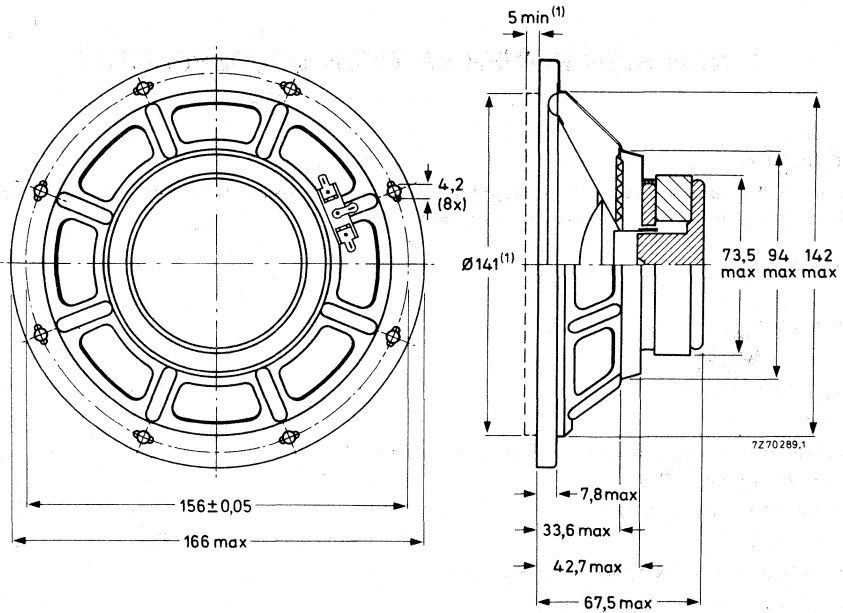

Fig. 1.

(1) Baffle hole and clearance depth required for cone movement at the specified power handling capacity.

One tag is indicated by a red mark for in-phase connection.

AVAILABLE VERSIONS

With rubber surround

AD70601/W4, catalogue number 2422 257 47121

AD70601/W8, catalogue number 2422 257 47122

With polyester surround

AD70602/W4, catalogue number 2422 257 47131

AD70602/W8, catalogue number 2422 257 47132

these numbers apply to bulk packed loudspeakers, minimum packing quantity 28 per unit.

FREQUENCY RESPONSE CURVES (See Fig. 2)

Measured in anechoic room at the operating power. Loudspeaker mounted in sealed 80 l enclosure, filled with 0,5 kg of glass wool.

Curve a: Sound pressure.

Curves d2 and d3: 2nd and 3rd harmonic distortion.

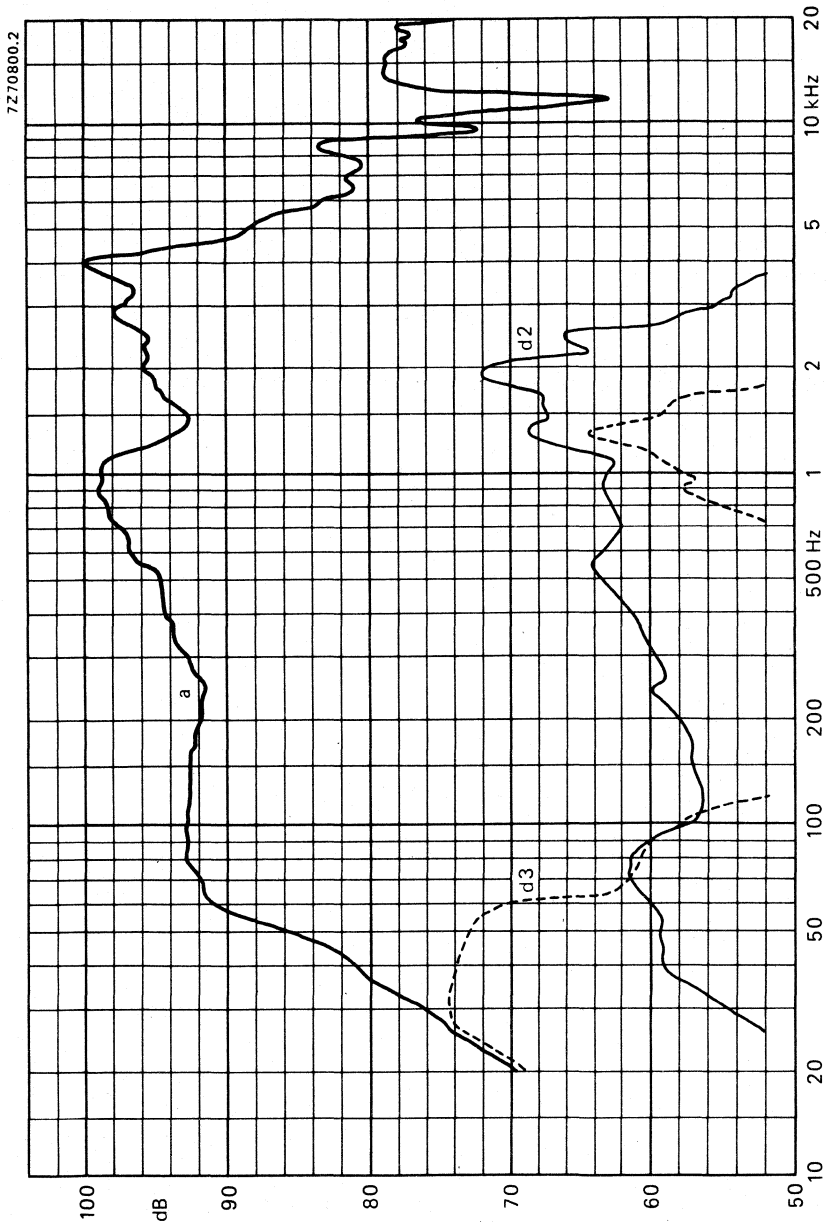

Fig. 2.



7 INCH HIGH POWER WOOFER LOUDSPEAKERS

APPLICATION

For high fidelity reproduction in sealed acoustic enclosures. Recommended enclosure volume 15 litres; maximum recommended cross-over frequency 3000 Hz. Smooth roll-off frequency characteristic.

TECHNICAL DATA

	version	
	W4	W8
Rated impedance	4	8 Ω
Voice coil resistance	4	8,5 Ω
Rated frequency range	50 to 4000 Hz	
Resonance frequency	44	46 Hz
Power handling capacity, measured without filter, mounted in 15 l sealed enclosure		30 W
Maximum power on loudspeaker		60 W
Operating power		12 W
Sweep voltage, frequency range: 35 to 4000 Hz	5	7 V
Energy in air gap	134	140 mJ
Flux density	0,64	0,72 T
Force factor (B x l) at 1 A	5,2	6,4 Wb/m
Total moving mass	12	11 g
Compliance, loudspeaker unmounted		1,1 mm/N
Air-gap height		5 mm
Voice coil height	10	11 mm
Core diameter		25 mm
Magnet material	ceramic	
diameter		72 mm
mass	0,29	kg
Mass of loudspeaker	1,32	kg

The loudspeakers have a paper cone and a textile surround. Type AD70610/W. has a foam plastic gasket, and type AD70611/W. has a second connecting plate permitting support of a filter capacitor. Two tinned 2,8 mm (0,11 inch) tag connectors permit connection to the tweeters by plugging or soldering.



AD70610/W.
AD70611/W.

Dimensions in mm

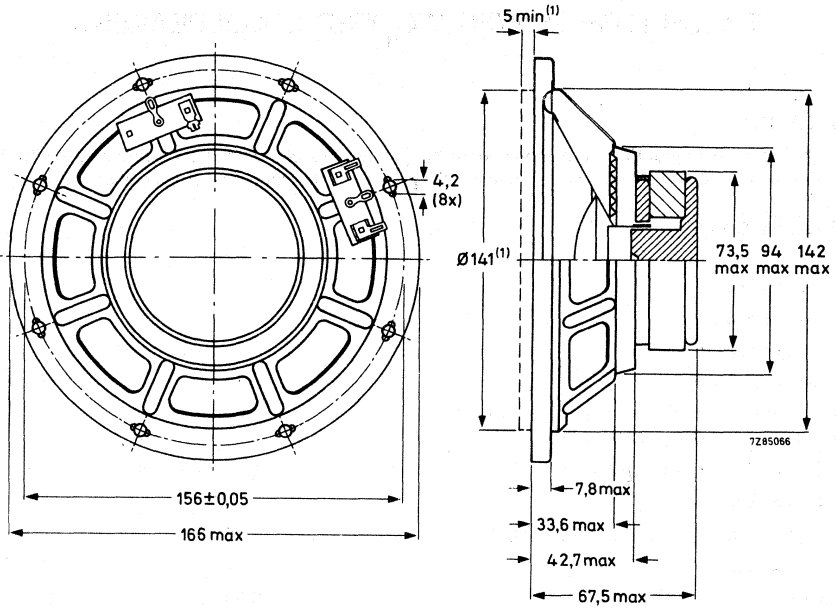

Fig. 1.

(1) Baffle hole and clearance depth required for cone movement at the specified power handling capacity.

One tag is indicated by a red mark for in-phase connection.

→ AVAILABLE VERSIONS

With foam plastic gasket

AD70610/W4, catalogue number 2422 257 37935

AD70610/W8, catalogue number 2422 257 37936

Without foam plastic gasket

AD70611/W4, catalogue number 2422 257 37937

AD70611/W8, catalogue number 2422 257 37938

these numbers apply to bulk-packed loudspeakers, minimum packing quantity 28 per unit.

FREQUENCY RESPONSE CURVES (See Fig. 2)

Measured in anechoic room at the operating power. Loudspeaker mounted in sealed 15 l enclosure.

Curve a: Sound pressure.

Curves d2 and d3: 2nd and 3rd harmonic distortion.

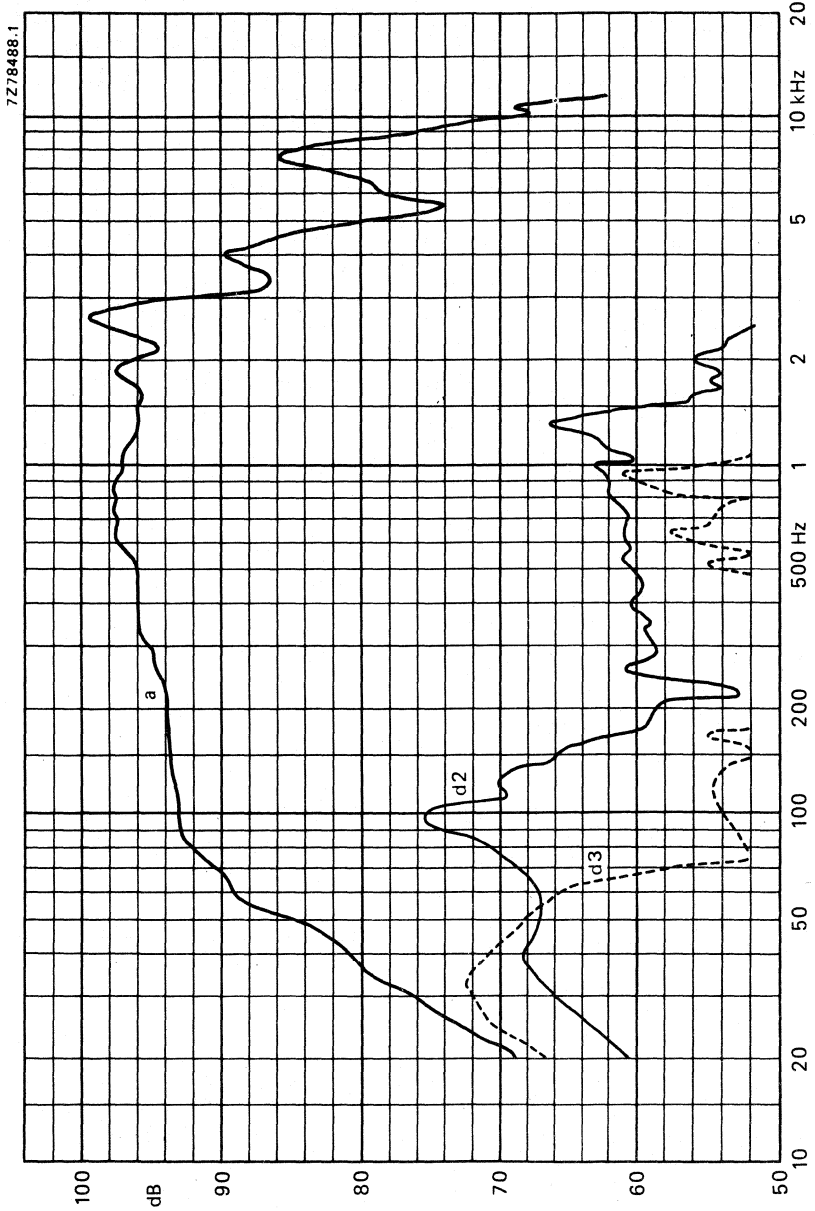

Fig. 2.



7 inch HIGH POWER WOOFER LOUDSPEAKER

APPLICATION

For high fidelity reproduction in sealed acoustic enclosure in accordance with DIN 45500. Maximum enclosure volume 15 l. Maximum recommended cross-over frequency 4000 Hz. High power handling capacity with very low distortion.

TECHNICAL DATA

	version	
	W4	W8
Rated impedance	4	8 Ω
Voice coil resistance	3,8	7 Ω
Rated frequency range	70 to 5000	
Resonance frequency	41	Hz
Power handling capacity, mounted in 15 l sealed enclosure, measured without filter	40	W
Maximum power on loudspeaker	80	W
Operating power	9	W
Sweep voltage, frequency range 35 to 5000 Hz	3,8	5,3 V
Maximum excursion voltage at 20 Hz	6,5	10 V
Energy in air gap	229	240 mJ
Flux density	1,1	1,2 T
Force factor (B x l) at 1 A	5,4	6,5 Wb/m
Total moving mass	13,2	g
Compliance, loudspeaker unmounted	1,2	mm/N
Quality factor		
mechanical		
electrical		
total		
Air-gap length	1,2	1 mm
Air-gap height		5 mm
Voice coil height		10 mm
Core diameter		25 mm
Magnet material	ceramic	
diameter	90	mm
mass	0,45	kg
Mass of loudspeaker	1,05	kg

The loudspeaker has a paper cone and a foam rubber surround. Two tinned 6,3 mm (0,25 inch) tag connectors permit connection to the woofer by plugging or soldering.

Dimensions in mm

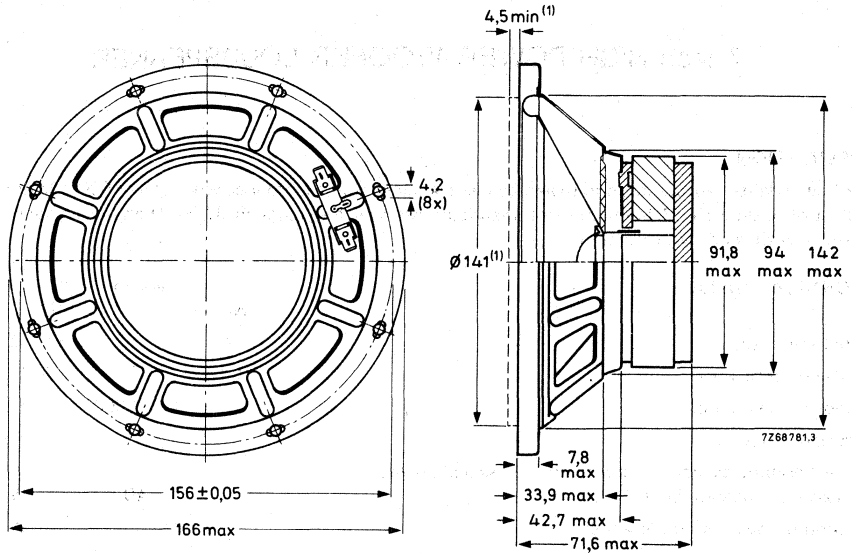

Fig. 1.

(1) Baffle hole and clearance depth required for cone movement at the specified power handling capacity.

One tag is indicated by a red mark for in-phase connection.

→ AVAILABLE VERSIONS

AD70650/W4, catalogue number 2422 257 47221

AD70650/W8, catalogue number 2422 257 47222

these numbers apply to bulk packed loudspeakers, minimum packing quantity 12 per unit.

FREQUENCY RESPONSE CURVES (See Fig. 2)

Measured in anechoic room at the operating power. Loudspeaker mounted in sealed 80 l enclosure, filled with 1 kg of glasswool.

Curve a: Sound pressure.

Curves d2 and d3: 2nd and 3rd harmonic distortion.

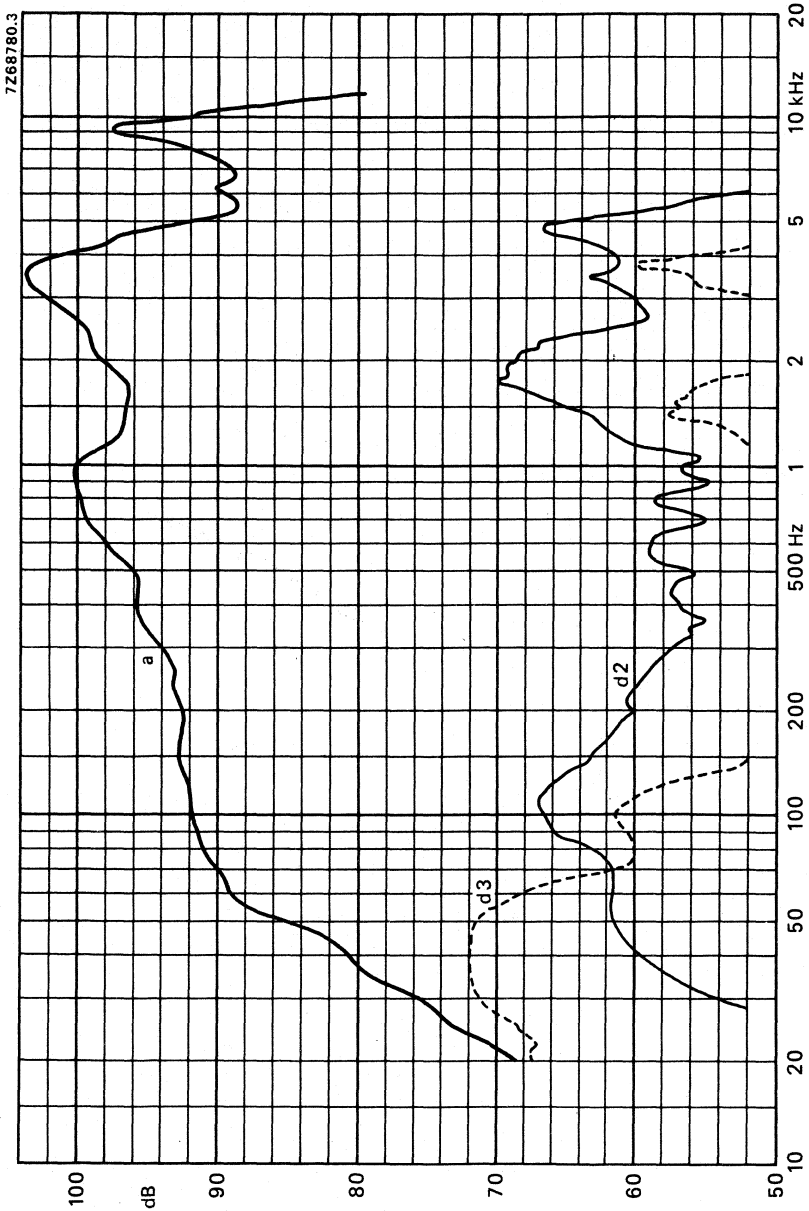

Fig. 2.



DEVELOPMENT SAMPLE DATA

This information is derived from development samples made available for evaluation. It does not necessarily imply that the device will go into regular production.

AD70652/W.

7 INCH HIGH POWER WOOFER LOUDSPEAKER

APPLICATION

For high-fidelity bass reproduction in sealed acoustic enclosure. Recommended volume of enclosure 15 litres. The loudspeaker has a very low distortion.

TECHNICAL DATA

	version	
	W4	W8
Rated impedance	4	8 Ω
Voice coil resistance	3,8	7,5 Ω
Rated frequency range	50 to 4000 Hz	
Resonance frequency	44	42 Hz
Power handling capacity, mounted in 15 l sealed enclosure, measured without filter	40	W
Maximum power on loudspeaker	80	W
Operating power	9	W
Sweep voltage, frequency range: 35 to 4000 Hz	5,5	8 V
Maximum excursion voltage at 20 Hz	to be established	
Energy in air gap	229	240 mJ
Flux density	1,1	1,2 T
Force factor (B x l) at 1 A	5,4	6,5 Wb/m
Total moving mass	13,2	13,2 g
Compliance, loudspeaker unmounted	1,03	1,13 mm/N
Quality factor		
mechanical	4,39	4,36
electrical	0,71	0,95
total	0,61	0,78
Air-gap length	1,2	1 mm
Air-gap height	5	mm
Voice coil height	10	mm
Core diameter	25	mm
Magnet material	ceramic	
diameter	90	mm
mass	0,45	kg
Mass of loudspeaker	1,05	1,05 kg

The loudspeaker has a paper cone and a foam plastic surround. Two tinned 6,3 mm (0,25 inch) tag connectors permit connection to the woofer by plugging or soldering.

Dimensions in mm

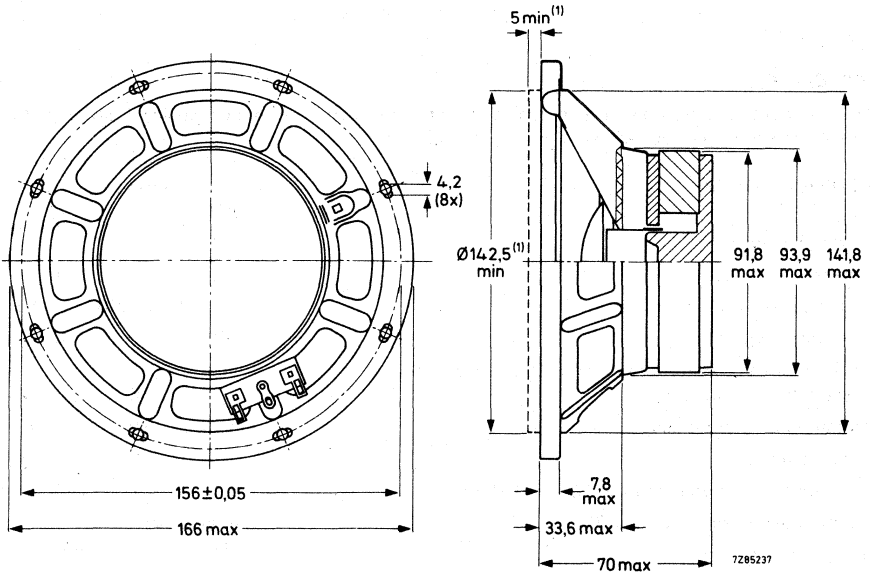

Fig. 1.

(1) Baffle hole and clearance depth required for cone movement at the specified power handling capacity.

One tag is indicated by a red mark for in-phase connection.

AVAILABLE VERSIONS

AD70652/W4, catalogue number 2422 257 47231

AD70652/W8, catalogue number 2422 257 47232

these numbers apply to bulk packed loudspeakers, minimum packing quantity 12 per unit.

FREQUENCY RESPONSE CURVES (See Fig. 2)

Measured in anechoic room at the operating power. Loudspeaker mounted on IEC baffle according to IEC 268-5 par. 4-4.

Curve a: Sound pressure.

Curves d2 and d3: 2nd and 3rd harmonic distortion.

DEVELOPMENT SAMPLE DATA

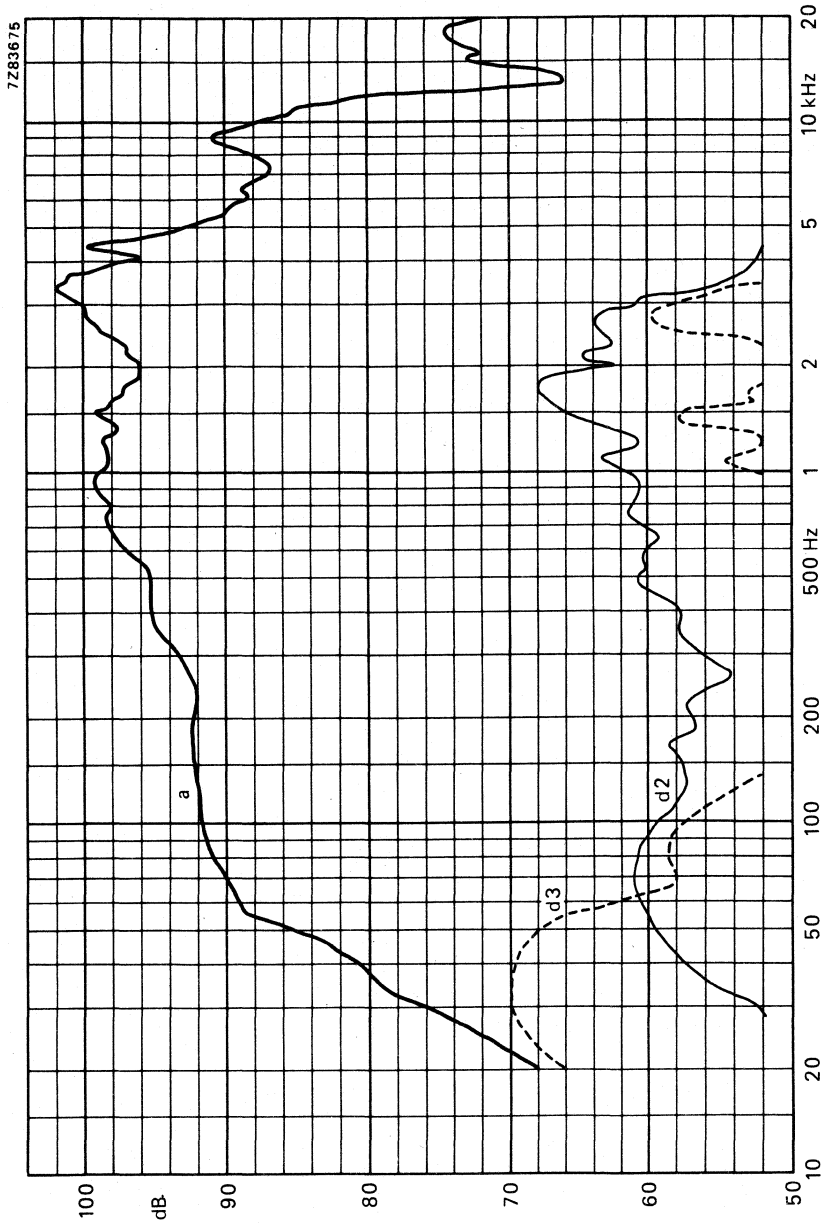

Fig. 2.



8 INCH HIGH POWER WOOFER LOUDSPEAKERS

APPLICATION

For high-fidelity reproduction in sealed acoustic enclosures. Maximum enclosure volume 25 litres.
Maximum recommended crossover frequency 2000 Hz.

TECHNICAL DATA

	version	
	W4	W8
Rated impedance	4	8 Ω
Voice coil resistance	3,6	7 Ω
Rated frequency range	50 to 2000 Hz	
Resonance frequency	42	Hz
Power handling capacity, measured without filter, mounted in 25 l sealed enclosure	50	W
Maximum power on loudspeaker	100	W
Operating power	5	W
Sweep voltage (frequency range 35 to 3000 Hz)	5	6,3 V
Maximum excursion voltage at 20 Hz	7	V
Characteristic sensitivity	to be established *	
Energy in air gap	135	mJ
Flux density	0,87	T
Force factor (B x l) at 1 A	4	5,5 Wb/m
Total moving mass	14	g
Compliance, loudspeaker unmounted	1,12	mm/N
Air-gap height	5	mm
Voice coil height	10	mm
Core diameter	25	mm
Magnet material	ceramic	
diameter	72	mm
mass	0,26	kg
Mass of loudspeaker	0,8	kg

Type AD80601/W. has a rubber surround, type AD80602/W. has a polyester surround (being the only difference between the two types). They have a round flange. Connection to the loudspeaker by means of 5,1 mm (0,2 inch) or 2,8 mm (0,11 inch) tag connectors or by soldering.

AD80601/W.
AD80602/W.

Dimensions in mm

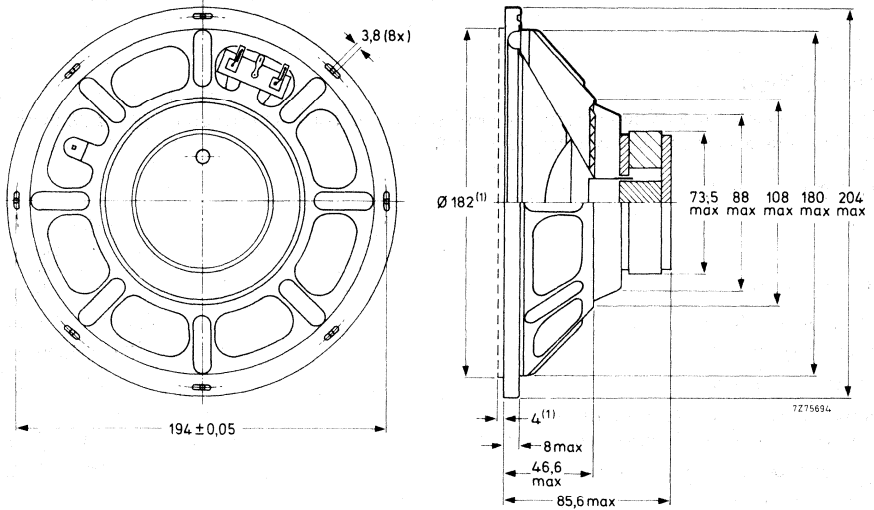

Fig. 1.

(1) Baffle hole and clearance depth required for cone movement at the specified power handling capacity.

One tag is indicated by a red mark for in-phase connection.

AVAILABLE VERSIONS

With rubber surround

AD80601/W4, catalogue number 2422 257 48221

AD80601/W8, catalogue number 2422 257 48222

With polyester surround

AD80602/W4, catalogue number 2422 257 48331

AD80602/W8, catalogue number 2422 257 48332

these numbers apply to bulk packed loudspeakers, minimum packing quantity 12 per unit.

FREQUENCY RESPONSE CURVES (See Fig. 2)

Measured in anechoic room at the operating power. Loudspeaker mounted in sealed 25 l enclosure, filled with 1 kg of glasswool.

Curve a: Sound pressure.

Curves d2 and d3: 2nd and 3rd harmonic distortion.

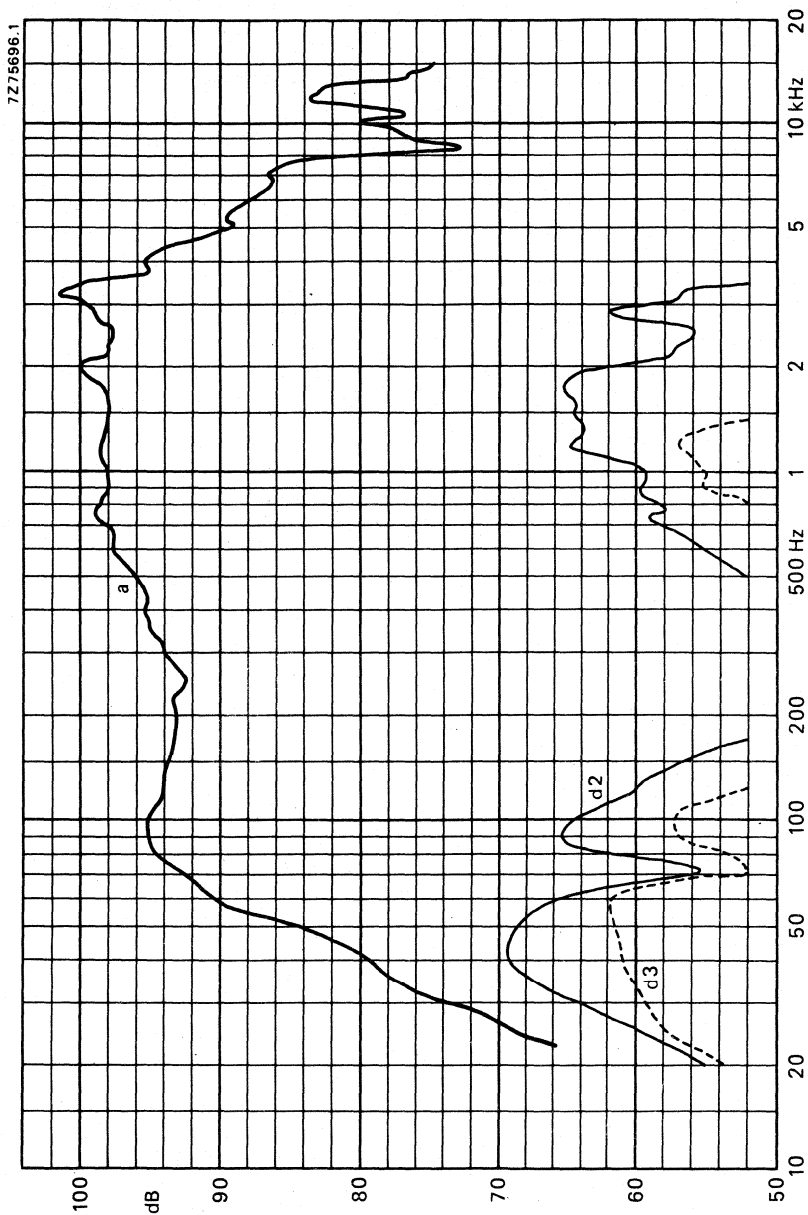

Fig. 2.



8 INCH HIGH POWER WOOFER LOUDSPEAKER

APPLICATION

For high-fidelity bass reproduction in bass reflex enclosure. Recommended volume of enclosure 25 litres. The loudspeaker has a smooth roll-off allowing a 6 dB per octave filter.

TECHNICAL DATA

	version	
	W4	W8
Rated impedance	4	8 Ω
Voice coil resistance	3,4	6,9 Ω
Rated frequency range	40 to 3500 Hz	
Resonance frequency	36	38 Hz
Power handling capacity, mounted in 80 l sealed enclosure, measured without filter	50	W
Maximum power on loudspeaker	100	W
Operating power	6	W
Sweep voltage, frequency range: 35 to 3500 Hz	4	5,6 V
Excursion voltage at 20 Hz	6,5	9 V
Characteristic sensitivity	to be established	
Energy in air gap	134	mJ
Flux density	0,64	T
Force factor (B x l) at 1 A	4,9	6 Wb/m
Total moving mass	18	16 g
Compliance, loudspeaker unmounted	1,16	1,18 mm/N
Air-gap length	1,9	mm
Air-gap height	5	mm
Voice coil height	12	mm
Core diameter	25	mm
Magnet material	ceramic	
diameter	72	mm
mass	0,26	kg
Mass of loudspeaker	0,77	kg

The loudspeaker has a paper cone and a foam plastic surround. Connection to the loudspeaker by means of 5,1 mm (0,2 inch) or 2,8 mm (0,11 inch) tag connectors or by soldering.

A second connecting plate permits support of a filter capacitor.

Dimensions (mm)

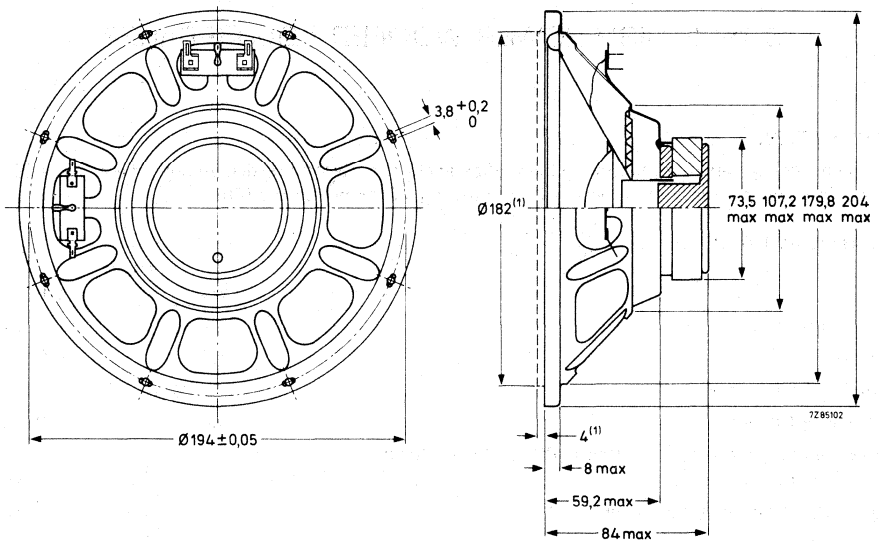

Fig. 1.

(1) Baffle hole and clearance depth required for cone movement at the specified power handling capacity.

One tag is indicated by a red mark for in-phase connection.

→ AVAILABLE VERSIONS

AD80603/W4 catalogue number 2422 257 48225
 AD80603/W8 catalogue number 2422 257 48226

} These numbers apply to bulk-packed loudspeakers, minimum packing quantity 12 per unit.

FREQUENCY RESPONSE CURVES (see Fig. 2)

Measured in half free field at the operating power. Loudspeaker mounted in 25 l enclosure.

Curve a: Sound pressure

Curves d2 and d3: 2nd and 3rd harmonic distortion.



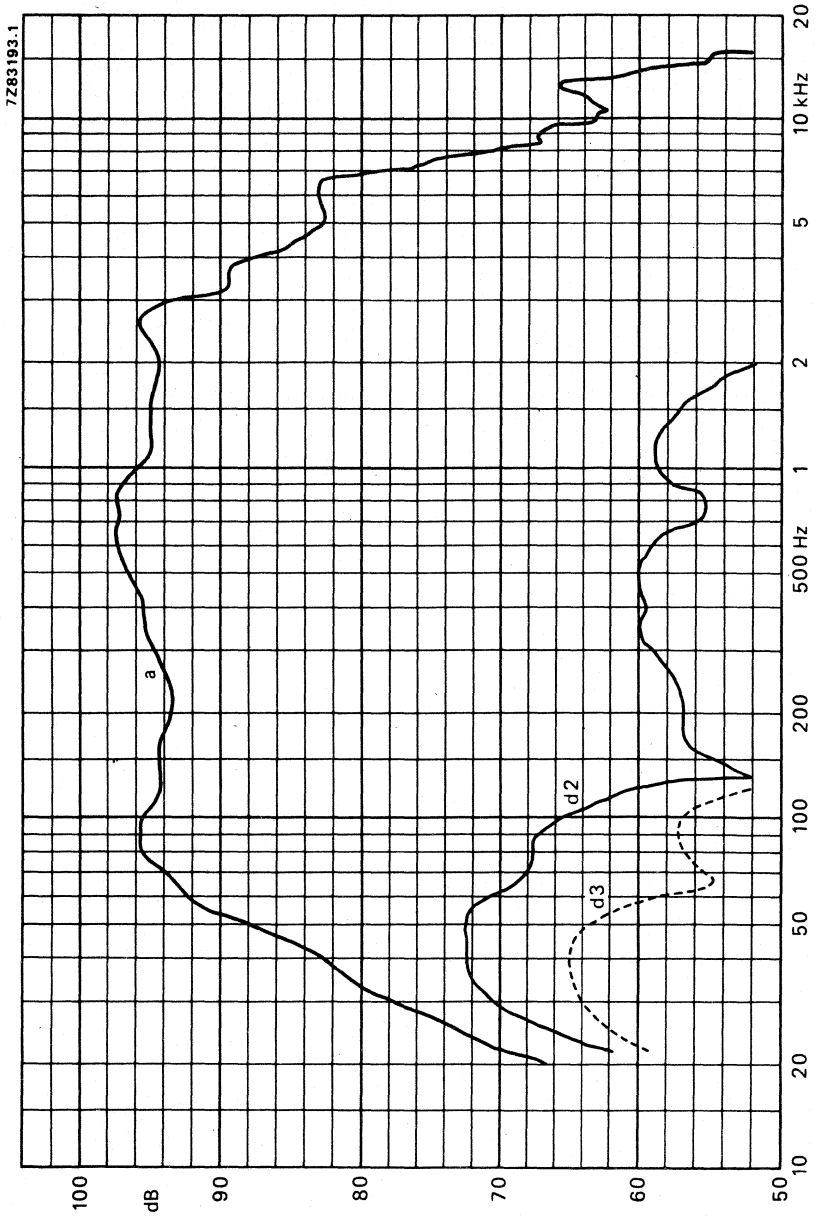

Fig. 2.



8 INCH HIGH POWER WOOFER LOUDSPEAKER

APPLICATION

For high-fidelity bass reproduction in bass reflex enclosure. Recommended volume of enclosure 25 litres. The loudspeaker has a smooth roll-off allowing a 6 dB per octave filter.

TECHNICAL DATA

	version	
	W4	W8
Rated impedance	4	8 Ω
Voice coil resistance	3,4	6,9 Ω
Rated frequency range	40 to 3500 Hz	
Resonance frequency	36	38 Hz
Power handling capacity, mounted in 80 l sealed enclosure, measured without filter	50	W
Maximum power on loudspeaker	100	W
Operating power	6	W
Sweep voltage, frequency range: 35 to 3500 Hz	4	5,6 V
Excursion voltage at 20 Hz	5,5	7,5 V
Characteristic sensitivity	to be established	
Energy in air gap	134	mJ
Flux density	0,64	T
Force factor (B x l) at 1 A	4,9	6 Wb/m
Total moving mass	18	16 g
Compliance, loudspeaker unmounted	1,26	1,29 mm/N
Air-gap length	1,9	mm
Air-gap height	5	mm
Voice coil height	12	mm
Core diameter	25	mm
Magnet material	ceramic	
diameter	72	mm
mass	0,26	kg
Mass of loudspeaker	0,77	kg

The loudspeaker has a paper cone and a rubber surround. Connection to the loudspeaker by means of 5,1 mm (0,2 inch) or 2,8 mm (0,11 inch) tag connectors or by soldering. A second connecting plate permits support of a filter capacitor.

Dimensions in mm

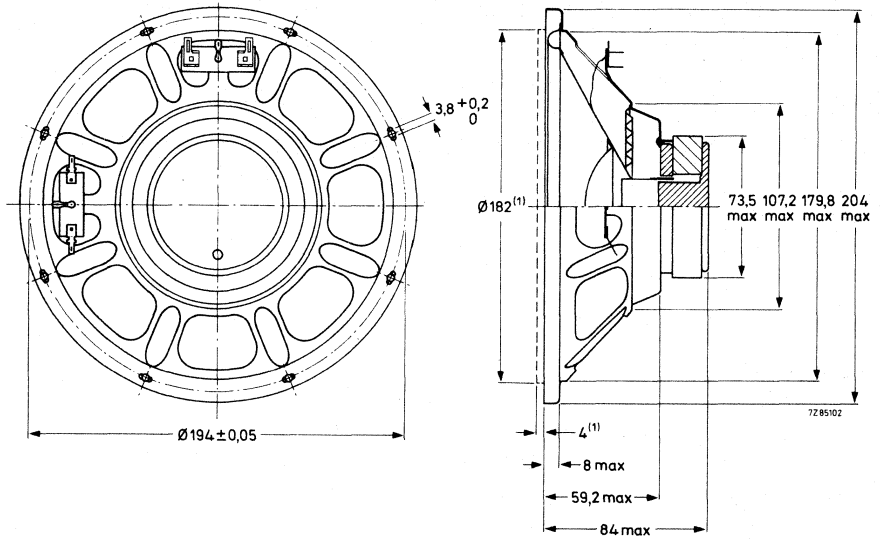

Fig. 1.

(1) Baffle hole and clearance depth required for cone movement at the specified power handling capacity.

One tag is indicated by a red mark for in-phase connection.

→ AVAILABLE VERSIONS

AD80604/W4 catalogue number 2422 257 48227
 AD80604/W8 catalogue number 2422 257 48228

} These numbers apply to bulk-packed loudspeakers, minimum packing quantity 12 per unit.

FREQUENCY RESPONSE CURVES (see Fig. 2)

Measured in half free field at the operating power. Loudspeaker mounted in 25 l enclosure.

Curve a: Sound pressure.

Curves d2 and d3: 2nd and 3rd harmonic distortion.

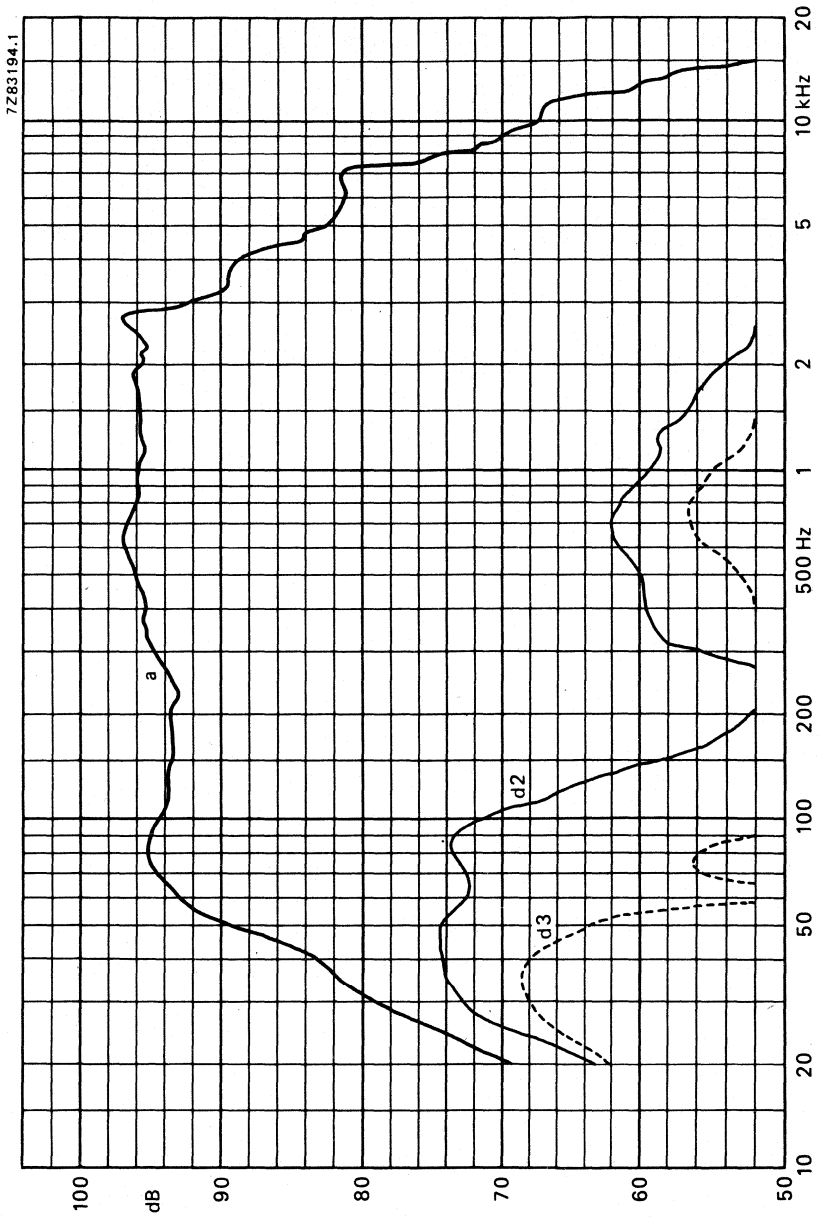

Fig. 2.



DEVELOPMENT SAMPLE DATA

This information is derived from development samples made available for evaluation. It does not necessarily imply that the device will go into regular production.

AD80605/W.

8 INCH HIGH POWER WOOFER LOUDSPEAKER

APPLICATION

For bass reproduction in high economy enclosures. Recommended volume enclosure 25 litres. The loudspeaker has a smooth roll-off allowing a 6 dB per octave filter.

TECHNICAL DATA

Rated impedance	6 Ω
Voice coil resistance	4,9 Ω
Rated frequency range	60 to 4000 Hz
Resonance frequency	50 Hz
Power handling capacity, mounted in 25 l sealed enclosure, measured without filter	40 W
Maximum power on loudspeaker	60 W
Operating power	4 W
Sweep voltage, frequency range: 35 to 4000 Hz	6 V
Quality factor	
mechanical	6,2
electrical	1,5
total	1,2
Characteristic sensitivity	to be established
Energy in air gap	166 mJ
Flux density	0,66 T
Force factor (B x l) at 1 A	4,6 Wb/m
Total moving mass	13,4 g
Compliance, loudspeaker unmounted	0,83 mm/N
Air-gap length	1,6 mm
Air-gap height	5 mm
Voice coil height	6,5 mm
Core diameter	25 mm
Magnet material	ceramic
diameter	72 mm
mass	0,16 kg
Mass of loudspeaker	0,65 kg

The loudspeaker has a paper cone and a foam rubber surround. Connection to the loudspeaker by means of 5,1 mm (0,2 inch) or 2,8 mm (0,11 inch) tag connectors or by soldering.



Dimensions in mm

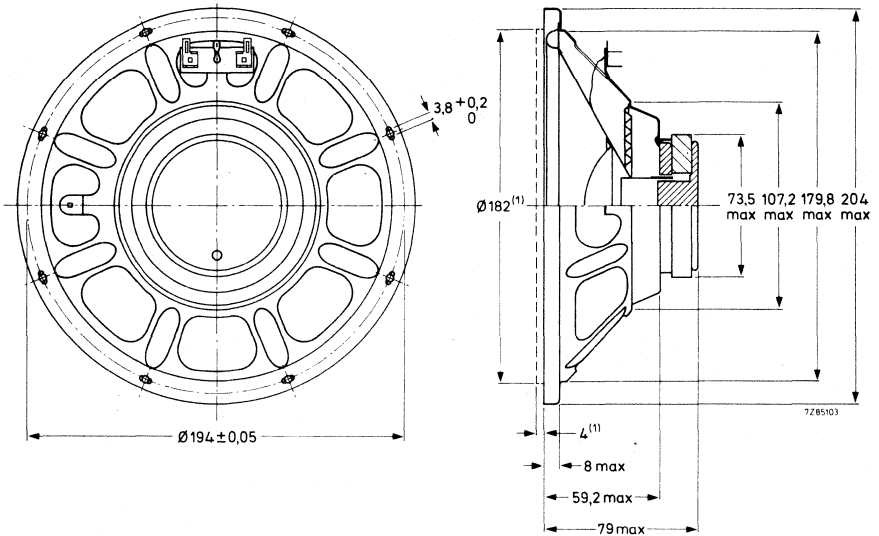

Fig. 1.

(1) Baffle hole and clearance depth required for cone movement at the specified power handling capacity.

One tag is indicated by a red mark for in-phase connection.

AVAILABLE VERSION

AD80605/W6, catalogue number 2422 257 48325

{ this number applies to bulk packed loudspeakers, minimum packing quantity 12 per unit.

FREQUENCY RESPONSE CURVES (see Fig. 2)

Measured in half free field at the operating power. Loudspeaker mounted in sealed 25 l enclosure.

Curve a: Sound pressure.

Curves d2 and d3: 2nd and 3rd harmonic distortion.



DEVELOPMENT SAMPLE DATA

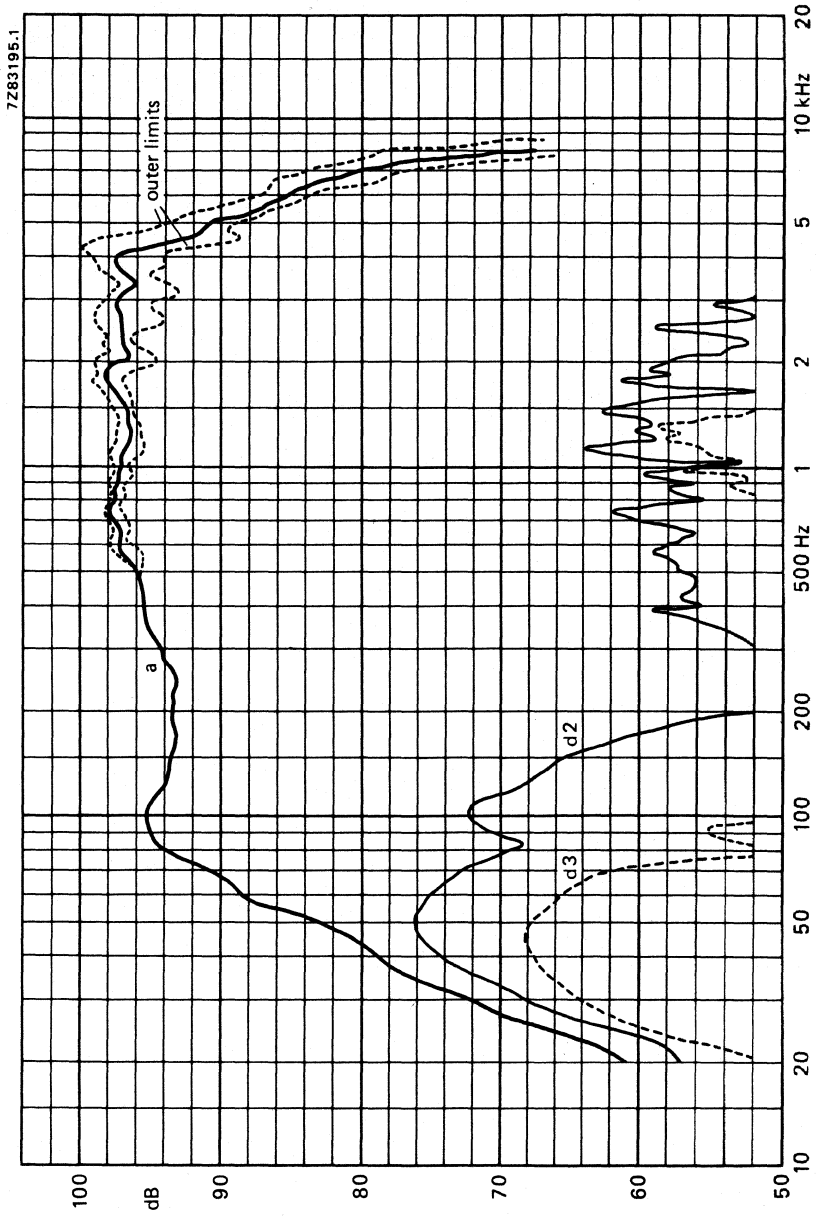

Fig. 2.



8 INCH HIGH POWER WOOFER LOUDSPEAKERS

APPLICATION

For high-fidelity reproduction in sealed acoustic enclosures. Maximum enclosure volume 25 litres.
Maximum recommended crossover frequency 2500 Hz.

TECHNICAL DATA

	version		
	W4	W8	
Rated impedance	4	8 Ω	
Voice coil resistance	3,8	7 Ω	
Rated frequency range	50 to 4000 Hz		←
Resonance frequency	39	Hz	
Power handling capacity, measured without filter, mounted in 25 l sealed enclosure	50	W	
Maximum power on loudspeaker	100	W	
Operating power	3,8	W	
Sweep voltage (frequency range 35 to 3000 Hz)	5	6,3 V	
Energy in air gap	229	240 mJ	←
Flux density	1,1	1,2 T	
Force factor (B x l) at 1 A	5,4	6,5 Wb/m	
Total moving mass	17,5	g	
Compliance, loudspeaker unmounted	1,02	mm/N	
Air-gap height	5	mm	
Voice coil height	10	mm	
Core diameter	25	mm	
Magnet material	ceramic		
diameter	90	mm	
mass	0,45	kg	
Mass of loudspeaker	1,15	kg	

Type AD80651/W. has a paper cone and a rubber surround, type AD80652/W. has a paper cone and a polyester surround (being the only difference between the two types). Connection to the loudspeaker by means of 5,1 mm (0,2 inch) or 2,8 mm (0,11 inch) tag connectors or by soldering.

AD80651/W.
AD80652/W.

Dimensions in mm

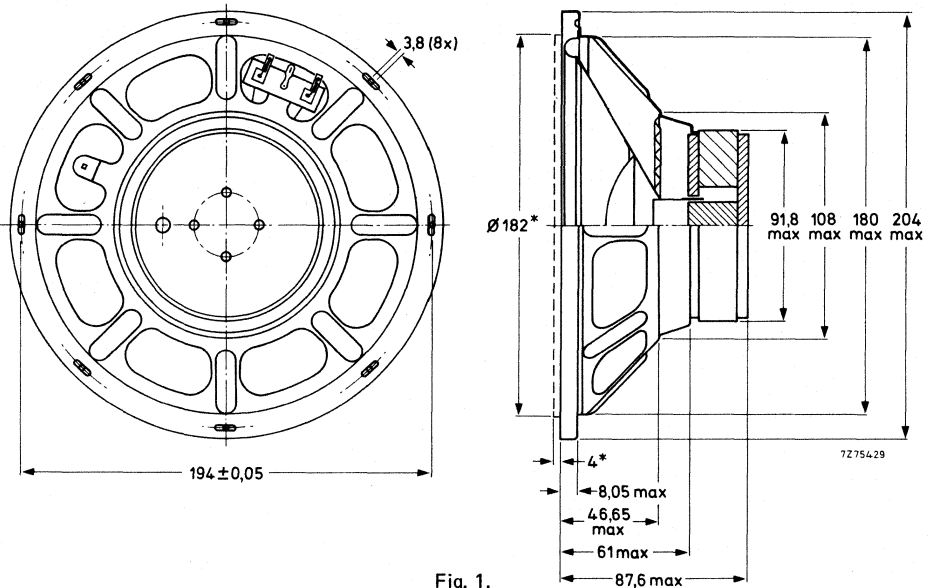

Fig. 1.

* Baffle hole and clearance depth required for cone movement at the specified power handling capacity.

One tag is indicated by a red mark for in-phase connection.

AVAILABLE VERSIONS

With rubber surround

AD80651/W4, catalogue number 2422 257 48421
AD80651/W8, catalogue number 2422 257 48422

With polyester surround

AD80652/W4, catalogue number 2422 257 48531
AD80652/W8, catalogue number 2422 257 48532

these numbers apply to bulk packed loudspeakers, minimum packing quantity 10 per unit.

FREQUENCY RESPONSE CURVES (See Fig. 2)

Measured in anechoic room at the operating power. Loudspeaker mounted in sealed 25 l enclosure, filled with 1 kg of glasswool.

Curve a: Sound pressure.

Curves d2 and d3: 2nd and 3rd harmonic distortion.

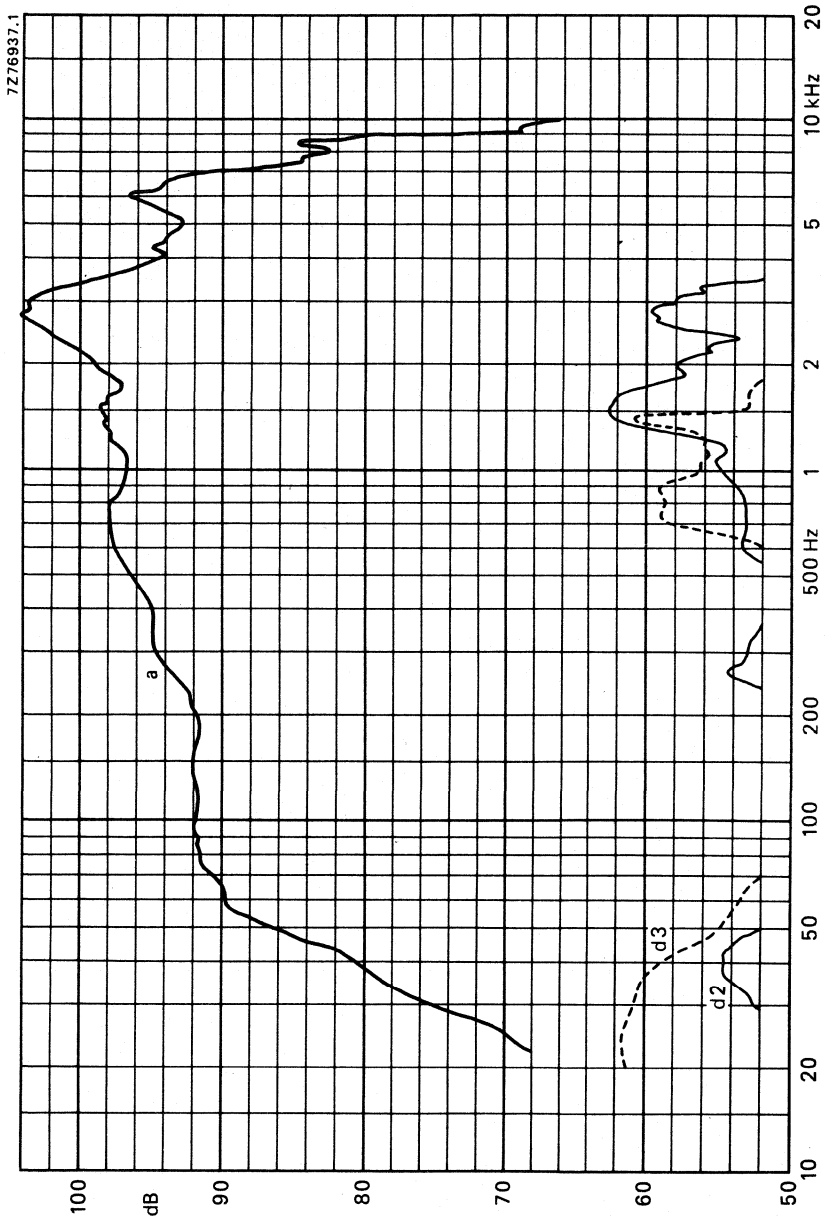

Fig. 2.



8 INCH HIGH POWER WOOFER LOUDSPEAKER

APPLICATION

For high-fidelity reproduction according to DIN 45500 in sealed acoustic enclosures. Maximum enclosure volume 25 litres. Maximum recommended crossover frequency 3000 Hz.

TECHNICAL DATA

	version	
	W4	W8
Rated impedance	4	8 Ω
Voice coil resistance	3,5	7,6 Ω
Rated frequency range	40 to 2000 Hz	
Resonance frequency	35	Hz
Power handling capacity, measured without filter, mounted in 25 l enclosure	60	W
Maximum power on loudspeaker	120	W
Operating power	9	W
Sweep voltage, frequency range: 35 to 3000 Hz	5	7 V
Maximum excursion voltage at 20 Hz	6,5	10,5 V
Characteristic sensitivity	to be established	
Energy in air gap	225	mJ
Flux density	0,69	T
Force factor (B x l) at 1 A	7	9,5 Wb/m
Total moving mass	27	24 g
Compliance, loudspeaker unmounted	0,84	0,85 mm/N
Air-gap height	5	mm
Voice coil height	14	mm
Core diameter	34	mm
Magnet material	ceramic	
diameter	90	mm
mass	0,42	kg
Mass of loudspeaker	1,3	kg

Type AD80671/W. has a paper cone and a rubber surround, type AD80672/W. has a paper cone and a polyester surround (being the only difference between the two types). Connection to the loudspeaker by means of 5,1 mm (0,2 inch) or 2,8 mm (0,11 inch) tag connectors or by soldering.

Dimensions in mm

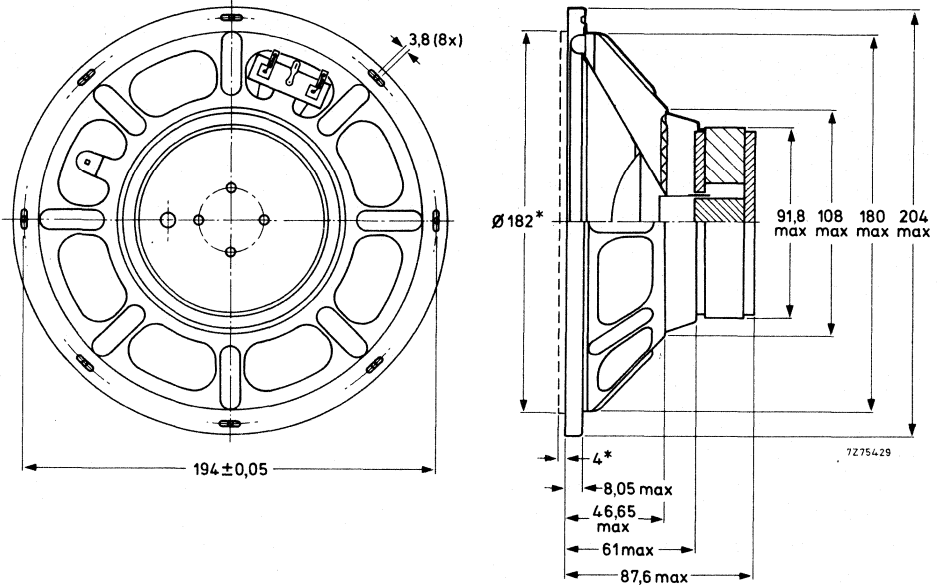

Fig. 1.

* Baffle hole and clearance depth required for cone movement at the specified power handling capacity.

One tag is indicated by a red mark for in-phase connection.

→ AVAILABLE VERSIONS

With rubber surround

AD80671/W4, catalogue number 2422 257 48621
AD80671/W8, catalogue number 2422 257 48622

With polyester surround

AD80672/W4, catalogue number 2422 257 48731
AD80672/W8, catalogue number 2422 257 48732

these numbers apply to bulk packed loudspeakers, minimum packing quantity 10 per unit.

FREQUENCY RESPONSE CURVES (See Fig. 2)

Measured in half free field at operating power. Loudspeaker mounted in sealed 25 l enclosure, filled with 1 kg of glass wool.

Curve a: Sound pressure.

Curves d2 and d3: 2nd and 3rd harmonic distortion.

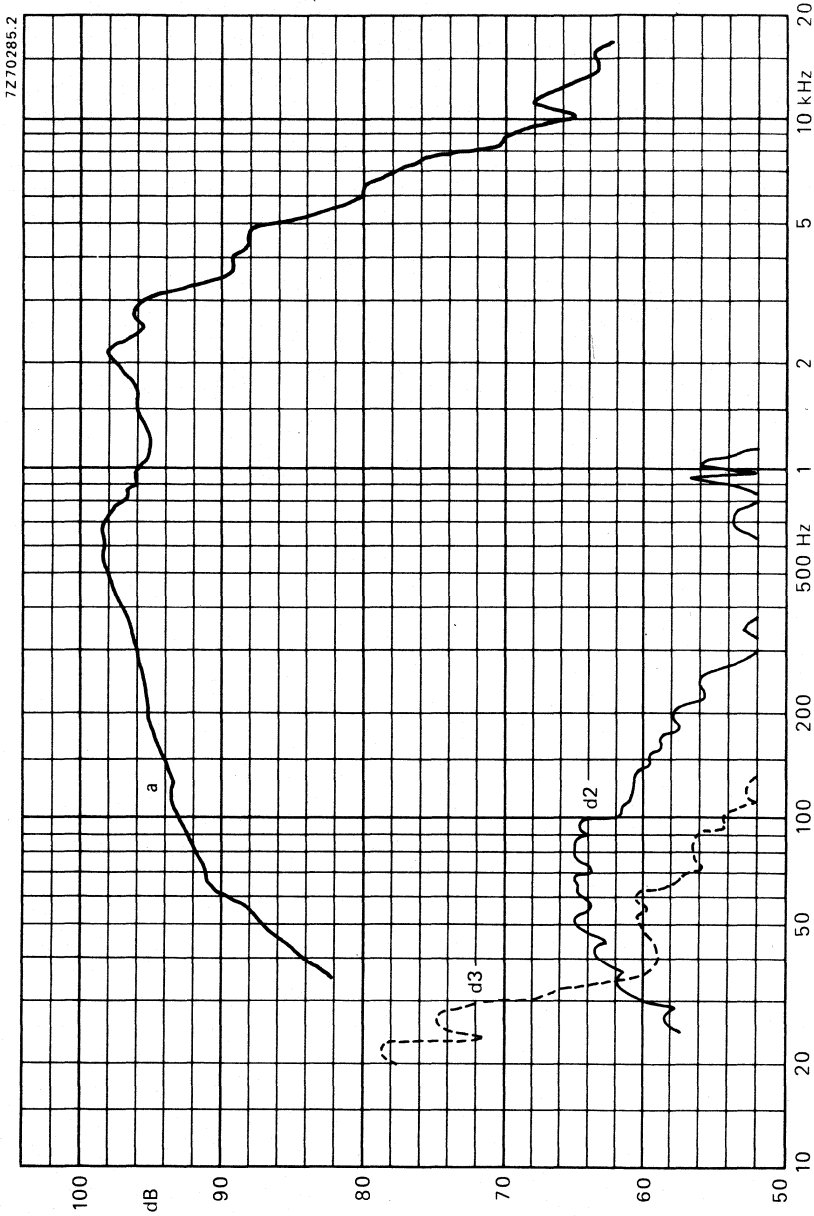

Fig. 2.



10 inch HIGH POWER WOOFER LOUDSPEAKER

APPLICATION

For high fidelity reproduction in sealed acoustic enclosures in accordance with DIN45500. Recommended enclosure volume 35 litres. Maximum recommended cross-over frequency 800 Hz. Rated frequency range 35 to 800 Hz.

TECHNICAL DATA

	version		
	W4	W8	
Rated impedance	4	8	Ω
Voice coil resistance	3,4	6,5	Ω
Resonance frequency	25	25	Hz
Power handling capacity, measured without filter mounted in 35 l sealed enclosure	40	40	W
Operating power	2,5	2,5	W
Sweep voltage	5	7	V
Energy in airgap	820	820	mJ
Flux density	1,03	1,03	T
Airgap height	8	8	mm
Voice coil height	15	17,2	mm
Core diameter	50	50	mm
Magnet material	ceramic	ceramic	
diameter	130	130	mm
mass	1,05	1,05	kg
Mass of loudspeaker	3,0	3,0	kg

The loudspeaker has a paper cone and a rubber surround.

Connection to the loudspeaker by means of 6,3 mm (0,25 inch) tag connectors or by soldering.

Dimensions in mm

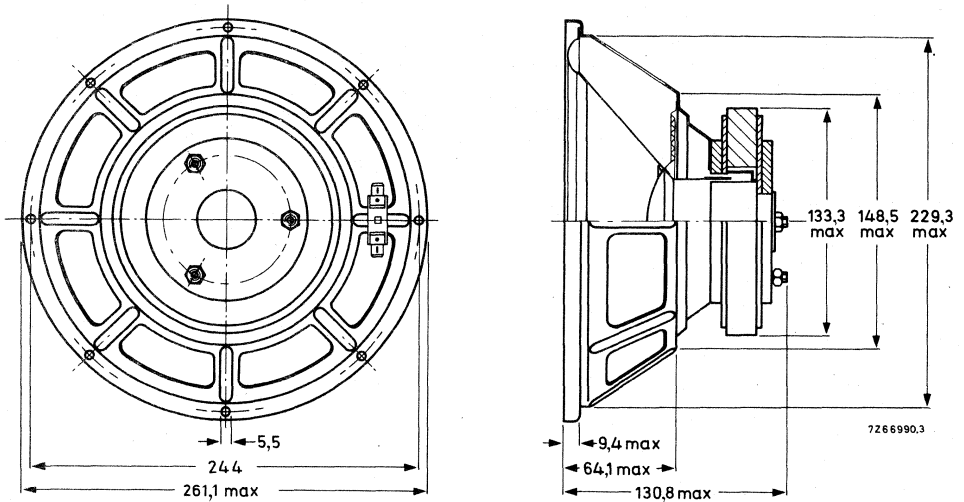

Fig. 1.

Baffle hole diameter 227 mm.

One tag is indicated by a red mark for in-phase connection.

AVAILABLE VERSIONS

AD10100/W4, catalogue number 2422 257 41221

AD10100/W8, catalogue number 2422 257 41222

these numbers apply to bulk packed loudspeakers, minimum packing quantity 4 per unit.

FREQUENCY RESPONSE CURVES (See Fig. 2)

Measured in anechoic room at operating power of 2,5 W. Loudspeaker mounted in sealed 80 l enclosure, filled with 1 kg of glass wool.

Curve b: Sound pressure.

Curves c_{d2} and c_{d3}: 2nd and 3rd harmonic distortion.



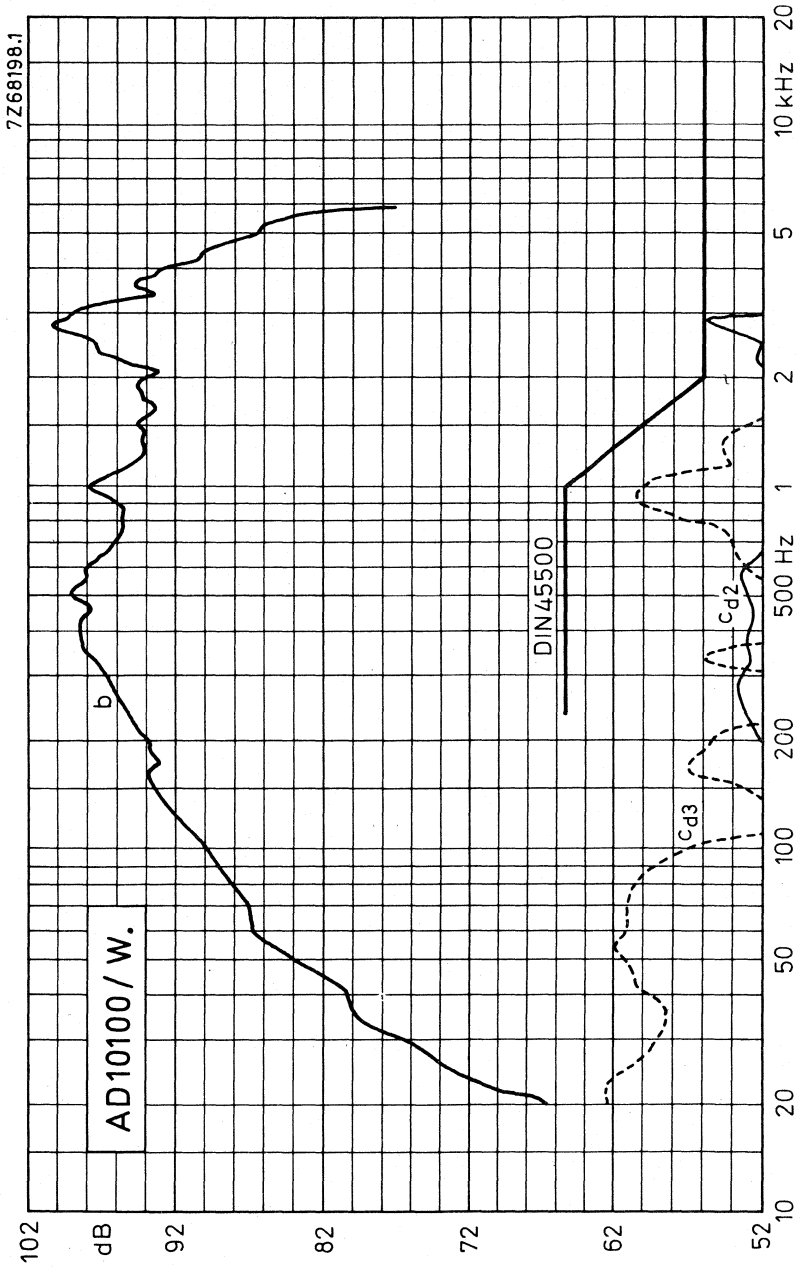

Fig. 2



DEVELOPMENT SAMPLE DATA

This information is derived from development samples made available for evaluation. It does not necessarily imply that the device will go into regular production.

AD10600/W8

10 INCH HIGH POWER WOOFER LOUDSPEAKER

APPLICATION

For high-fidelity bass reproduction in sealed acoustic enclosure. Recommended volume of enclosure 35 litres. The loudspeaker has a very low distortion.

TECHNICAL DATA

Rated impedance	8 Ω
Voice coil resistance	6,8 Ω
Rated frequency range	55 to 2500 Hz
Resonance frequency	39 Hz
Power handling capacity, mounted in 35 l sealed enclosure, measured without filter	40 W
Maximum power on loudspeaker	60 W
Operating power	5 W
Sweep voltage, frequency range: 20 to 2500 Hz	7 V
Maximum excursion voltage at 20 Hz	8 V
Energy in air gap	123 mJ
Flux density	0,62 T
Force factor (B x l) at 1 A	5,9 Wb/m
Total moving mass	26 g
Compliance, loudspeaker unmounted	0,7 mm/N
Quality factor	
mechanical	8,64
electrical	2,23
total	1,77
Air-gap length	1,9 mm
Air-gap height	5 mm
Voice coil height	12 mm
Core diameter	25 mm
Magnet material	ceramic
diameter	72 mm
mass	0,29 kg
Mass of loudspeaker	1,05 kg

The loudspeaker has a paper cone and a foam plastic surround. Two tinned 5,1 mm (0,2 inch) or 2,8 mm (0,11 inch) tag connectors permit connection to the woofer by plugging or soldering.

Dimensions in mm

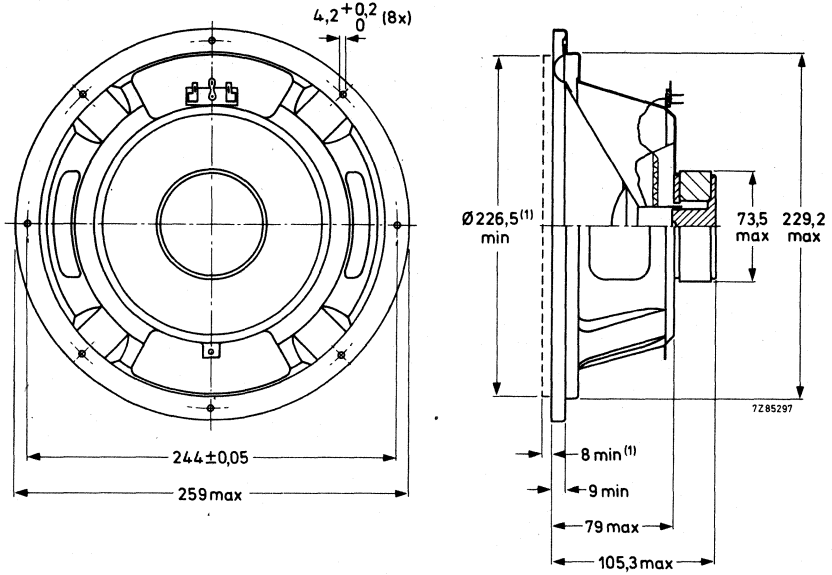

Fig. 1.

(1) Baffle hole and clearance depth required for cone movement at the specified power handling capacity.

One tag is indicated by a red mark for in-phase connection.

AVAILABLE VERSION

AD10600/W8, catalogue number 2422 257 31622

{ this number applies to bulk packed loudspeakers, minimum packing quantity 4 per unit.

FREQUENCY RESPONSE CURVES (See Fig. 2)

Measured in anechoic room at the operating power. Loudspeaker mounted on IEC baffle according to IEC 268-5 par. 4-4.

Curve a: Sound pressure.

Curves d2 and d3: 2nd and 3rd harmonic distortion.

DEVELOPMENT SAMPLE DATA

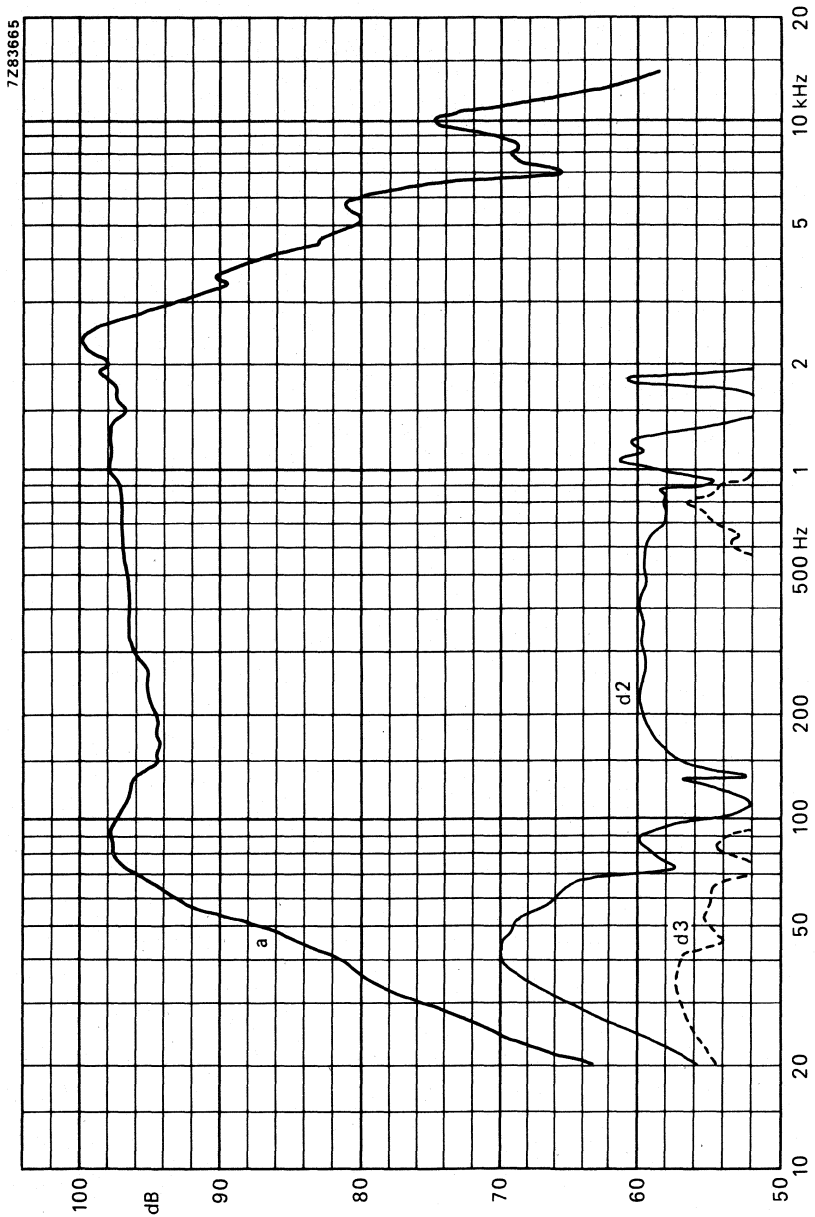

Fig. 2.



12 INCH HIGH POWER WOOFER LOUDSPEAKER

APPLICATION

For high-fidelity bass reproduction in sealed acoustic enclosure. Recommended volume of enclosure 80 litres. The loudspeaker has a very low distortion.

TECHNICAL DATA

	version	
	W4	W8
Rated impedance	4	8 Ω
Voice coil resistance	3,3	6,7 Ω
Rated frequency range	35 to 1800 Hz	
Resonance frequency	22	24 Hz
Power handling capacity, mounted in 80 l sealed enclosure, measured without filter		80 W
Maximum power on loudspeaker		150 W
Operating power		5 W
Sweep voltage, frequency range: 35 to 2000 Hz	7	10 V
Characteristic sensitivity		88 dB
Energy in air gap	485	508 mJ
Flux density	0,65	0,72 T
Force factor (B x l) at 1 A	9,5	13 Wb/m
Total moving mass	67×10^{-3}	62×10^{-3} kg
Compliance, loudspeaker unmounted	$0,8 \times 10^{-3}$	$0,76 \times 10^{-3}$ m/N
Air-gap height		7 mm
Voice coil height		17 mm
Core diameter		50 mm
Magnet material	ceramic	
diameter		125 mm
mass		0,85 kg
Mass of loudspeaker		3 kg

The loudspeaker has a paper cone, a rubber surround and black foam gaskets. Connection to the loudspeaker by means of 5,1 mm (0,2 inch) or 2,8 mm (0,11 inch) tag connectors or by soldering.

Dimensions in mm

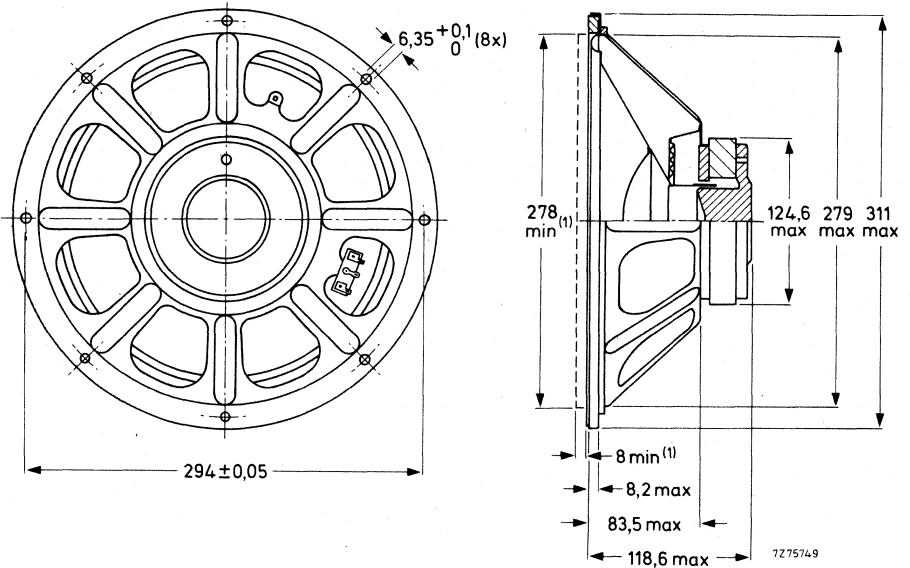

Fig. 1.

(1) Baffle hole and clearance depth required for cone movement at the specified power handling capacity.

One tag is indicated by a red mark for in-phase connection.

AVAILABLE VERSIONS

AD12200/W4, catalogue number 2422 257 31531
 AD12200/W8, catalogue number 2422 257 31532

these numbers apply to bulk packed loudspeakers, minimum packing quantity 4 per unit.

FREQUENCY RESPONSE CURVES (See Fig. 2)

Measured in anechoic room at the operating power. Loudspeaker mounted in sealed 80 l enclosure, filled with 0,5 kg of glass wool.

Curve a: Sound pressure.

Curves d2 and d3: 2nd and 3rd harmonic distortion.



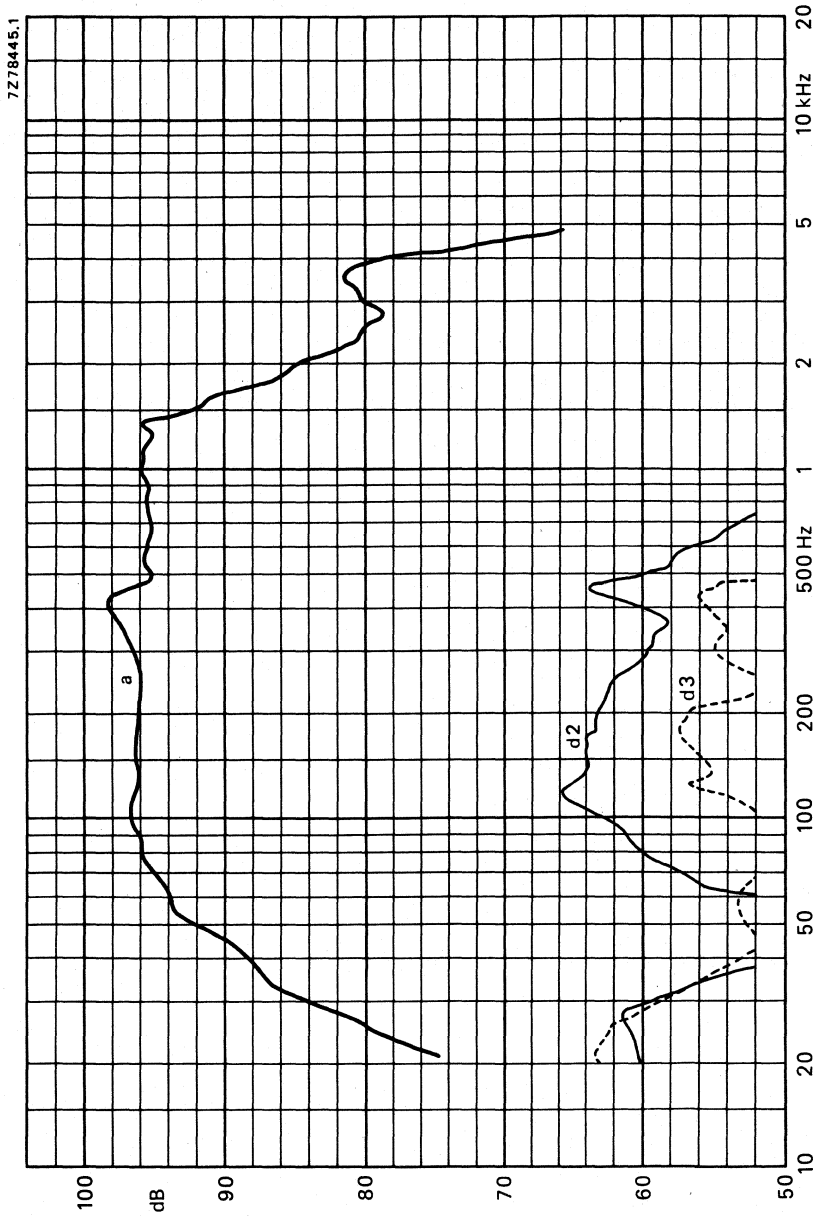

Fig. 2.



12 INCH HIGH POWER WOOFER LOUDSPEAKER

APPLICATION

For high-fidelity bass reproduction in sealed acoustic enclosure. Recommended volume of enclosure 80 litres. The loudspeaker has a very low distortion.

TECHNICAL DATA

	version	
	W4	W8
Rated impedance	4	8 Ω
Voice coil resistance	3,4	6,6 Ω
Rated frequency range	40 to 1800 Hz	
Resonance frequency	25	27 Hz
Power handling capacity, mounted in 80 l sealed enclosure, measured without filter	100	W
Maximum power on loudspeaker	150	W
Operating power	2,9	W
Sweep voltage, frequency range: 35 to 2000 Hz	7	10 V
Characteristic sensitivity	91,0	91,3 dB
Energy in air gap	803	mJ
Flux density	1,02	T
Force factor (B x l) at 1 A (air mass included)	9,5	13 Wb/m
Total moving mass	56×10^{-3}	54×10^{-3} kg
Compliance, loudspeaker unmounted	$0,77 \times 10^{-3}$	$0,70 \times 10^{-3}$ m/N
Air-gap height	8	mm
Voice coil height	24	mm
Core diameter	50	mm
Magnet material	ceramic	
diameter	138	mm
mass	1,15	kg
Mass of loudspeaker	3,8	kg

The loudspeaker has a paper cone and a rubber surround. Connection to the loudspeaker by means of 5,1 mm (0,2 inch) or 2,8 mm (0,11 inch) tag connectors or by soldering.

Dimensions in mm

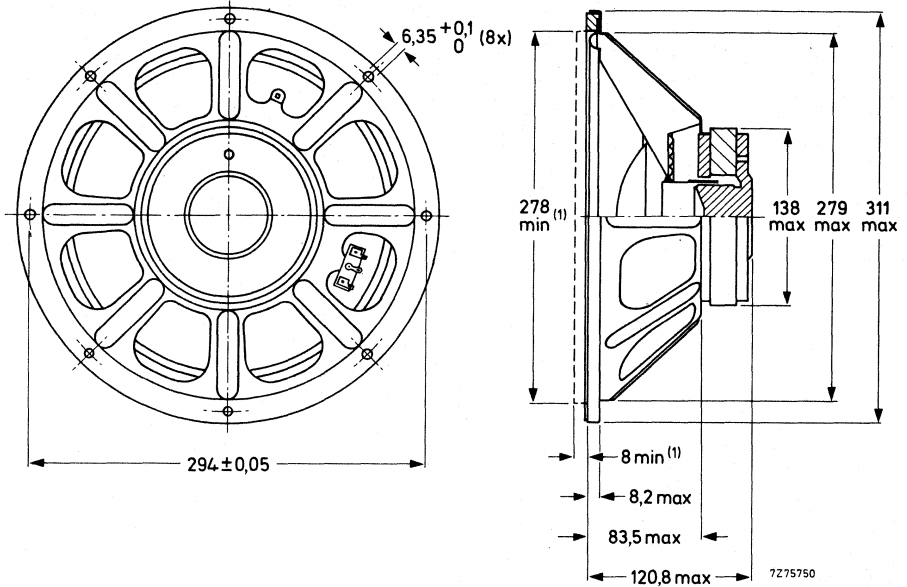

Fig. 1.

(1) Baffle hole and clearance depth required for cone movement at the specified power handling capacity.

One tag is indicated by a red mark for in-phase connection.

AVAILABLE VERSIONS

AD12250/W4, catalogue number 2422 257 61031

AD12250/W8, catalogue number 2422 257 61032

these numbers apply to bulk packed loudspeakers, minimum packing quantity 4 per unit.

FREQUENCY RESPONSE CURVES (See Fig. 2)

Measured in anechoic room at the operating power. Loudspeaker mounted in sealed 80 l enclosure, filled with 0,5 kg of glass wool.

Curve a: Sound pressure.

Curves d2 and d3: 2nd and 3rd harmonic distortion.

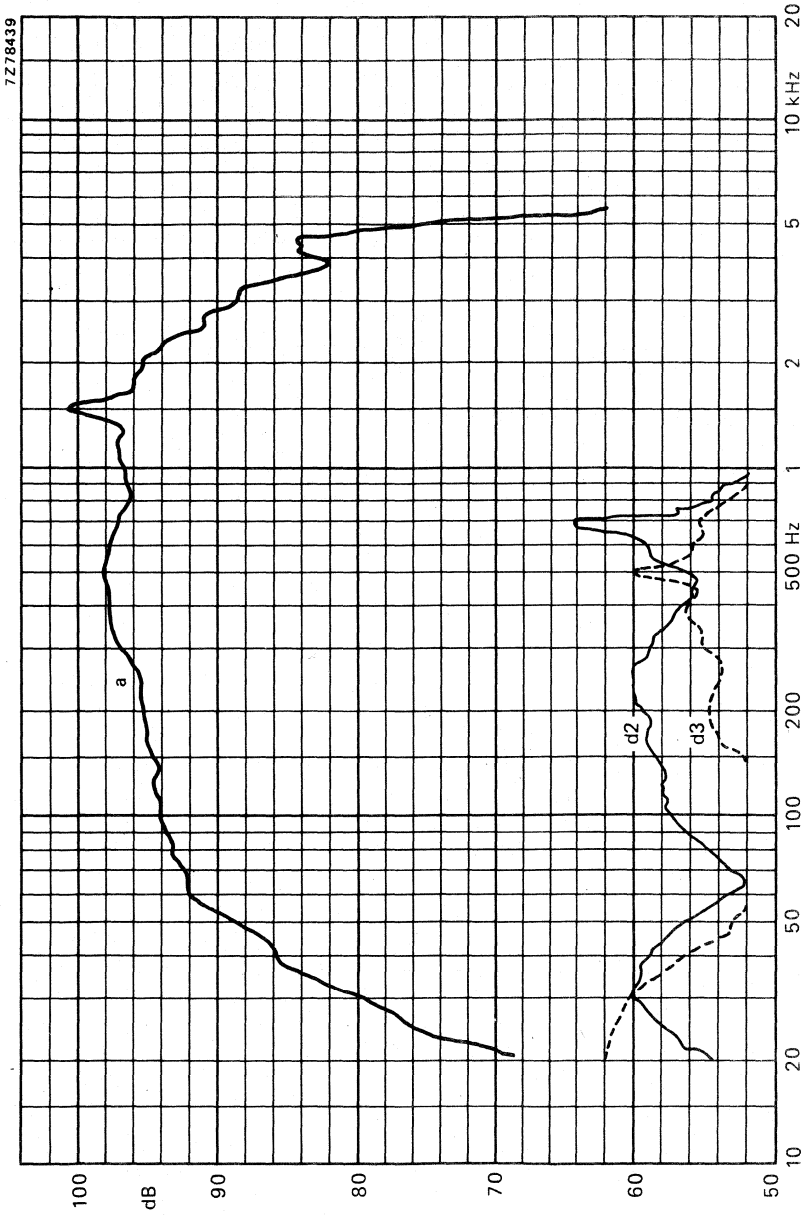

Fig. 2.



12 INCH HIGH POWER WOOFER LOUDSPEAKER

APPLICATION

For high-fidelity bass reproduction in sealed acoustic enclosure. Recommended volume of enclosure 80 litres. The loudspeaker has a very low distortion.

TECHNICAL DATA

	version	
	W4	W8
Rated impedance	4	8 Ω
Voice coil resistance	3,4	6,9 Ω
Rated frequency range	40 to 1500 Hz	
Resonance frequency	31	33 Hz
Power handling capacity, mounted in 80 l sealed enclosure, measured without filter	40	W
Maximum power on loudspeaker	80	W
Operating power	4	W
Sweep voltage, frequency range: 35 to 1500 Hz	6	8,5 V
Maximum excursion voltage at 20 Hz	7	10 V
Characteristic sensitivity	88	dB
Energy in air gap	129	mJ
Flux density	0,63	T
Force factor (B x l) at 1 A	4,9	6,8 Wb/m
Total moving mass	35	33 g
Compliance, loudspeaker unmounted	0,87	0,83 mm/N
Air-gap height	5	mm
Voice coil height	12	mm
Core diameter	25	mm
Magnet material	ceramic	
diameter	72	mm
mass	0,29	kg
Mass of loudspeaker	1,32	kg

The loudspeaker has a paper cone and a foam rubber surround. Connection to the loudspeaker by means of 5,1 mm (0,2 inch) or 2,8 mm (0,11 inch) tag connectors or by soldering.

Dimensions (mm)

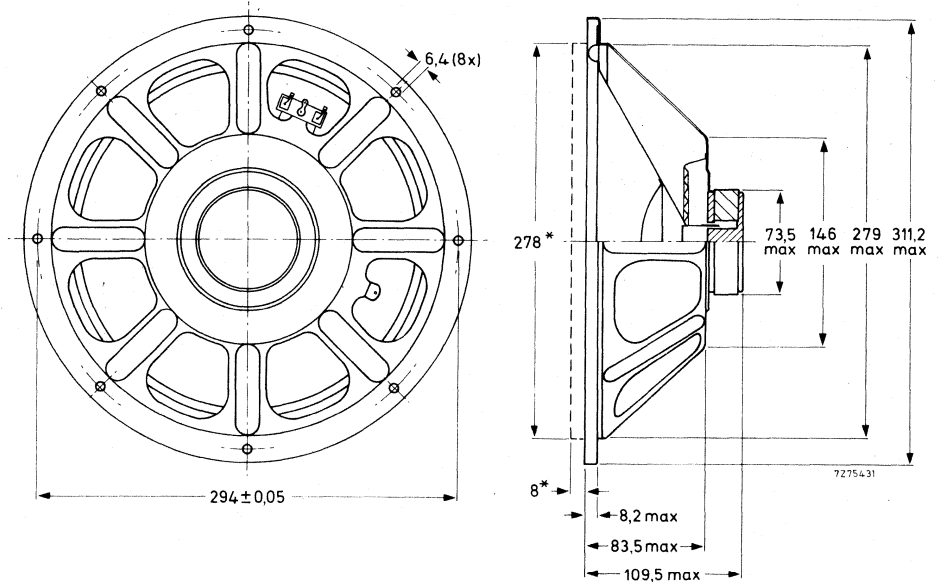

Fig.1

* Baffle hole and clearance depth required for cone movement at the specified power handling capacity.

One tag is indicated by a red mark for in-phase connection.

→ AVAILABLE VERSIONS

AD12600/W4, catalogue number 2422 257 21031
 AD12600/W8, catalogue number 2422 257 21032

these numbers apply to bulk packed loudspeakers, minimum packing quantity 4 per unit.

FREQUENCY RESPONSE CURVE (See Fig. 2)

Measured in anechoic room at the operating power. Loudspeaker mounted in sealed 80 l enclosure, filled with 0,5 kg of glass wool.

Curve a: Sound pressure.

Curves d2 and d3: 2nd and 3rd harmonic distortion.

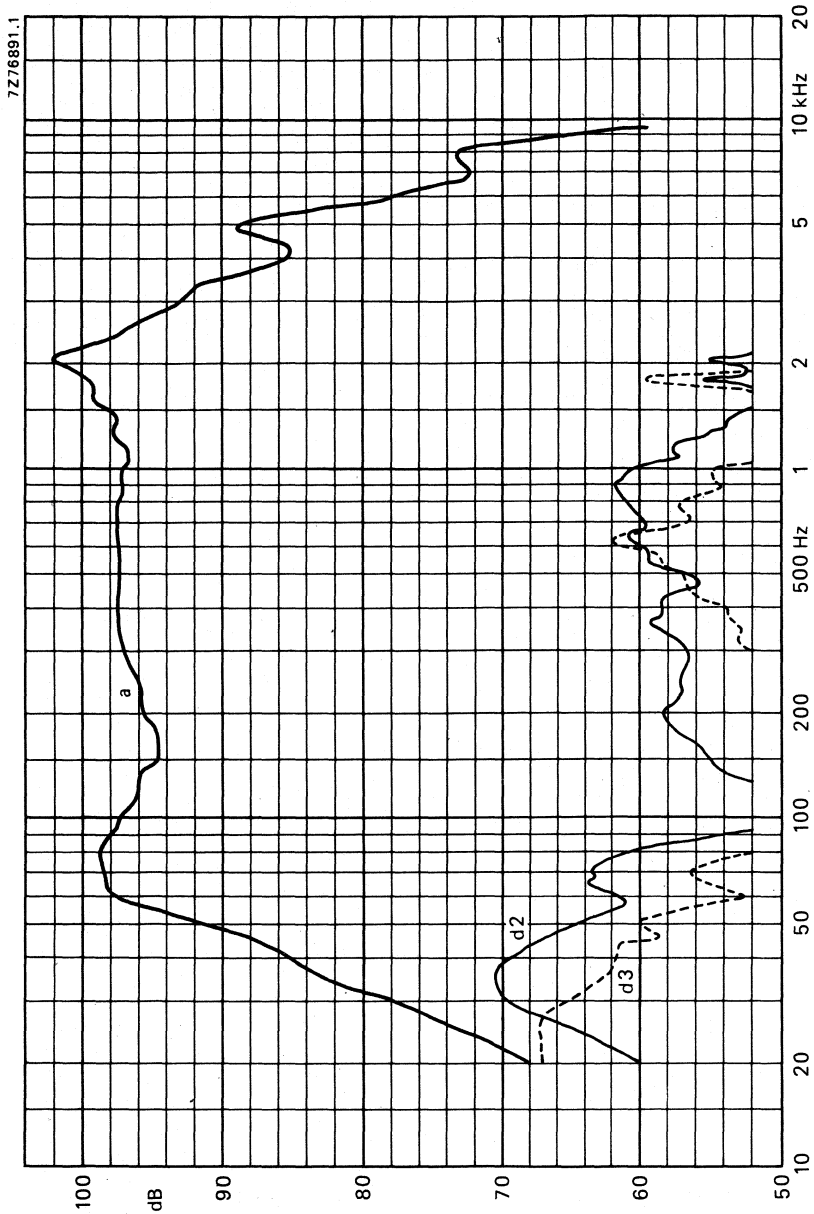

Fig. 2



12 INCH HIGH POWER WOOFER LOUDSPEAKER

APPLICATION

For high-fidelity bass reproduction in sealed acoustic enclosure. Recommended volume of enclosure 80 litres. The loudspeaker has a very low distortion.

TECHNICAL DATA

	version	
	W4	W8
Rated impedance	4	8 Ω
Voice coil resistance	3	5,9 Ω
Rated frequency range	35 to 2000 Hz	
Resonance frequency, tolerance ± 3 Hz	25	26 Hz
Resonance frequency, mounted in 80 l sealed enclosure	49	50 HL
Power handling capacity, mounted in 80 l sealed enclosure, measured without filter	60	W
Maximum power on loudspeaker	100	W
Operating power	5	4 W
Sweep voltage, frequency range: 35 to 3500 Hz	7,5	8,5 V
Maximum excursion voltage at 20 Hz	11	14 V
Characteristic sensitivity	87	88 dB
Energy in air-gap	229	248 mJ
Flux density	0,68	0,72 T
Force factor (B x l) at 1 A	6,3	7,7 Wb/m
Total moving mass	52	49 g
Compliance, loudspeaker unmounted	0,86	0,85 mm/N
Quality factor		
mechanical	8,16	6,25
electrical	1,2	1,53
total	1	1,23
Air-gap length	5	mm
Air-gap height	2,35	2,15 mm
Voice coil height	16	mm
Core diameter	35	mm
Magnet material	ceramic	
diameter	90	mm
mass	0,53	kg
Mass of loudspeaker	1,8	kg

The loudspeaker has a paper cone and a rubber surround. Two tinned 5,1 mm (0,2 inch) or 2,8 mm (0,11 inch) tag connectors permit connection to the woofer by plugging or soldering.

Dimensions in mm

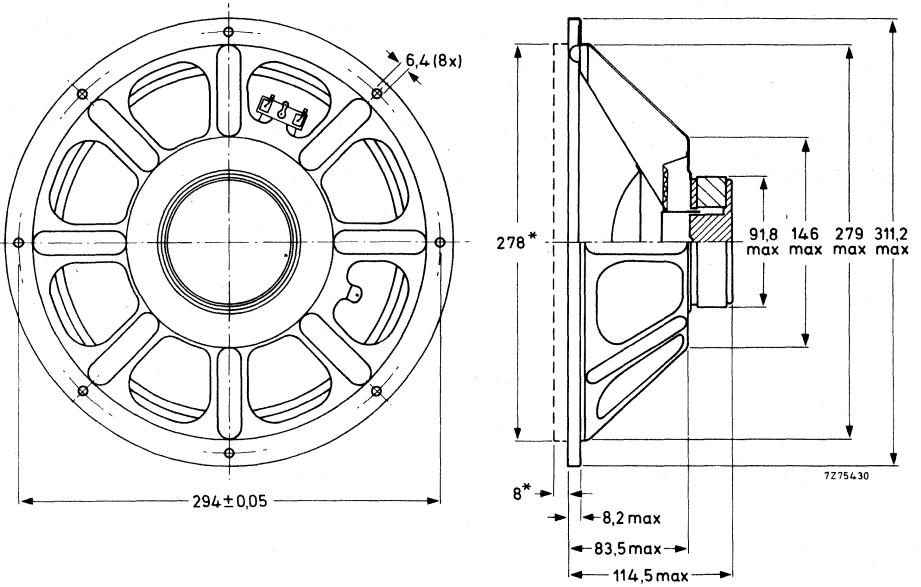

Fig. 1.

* Baffle hole and clearance depth required for cone movement at the specified power handling capacity.

One tag is indicated by a red mark for in-phase connection.

AVAILABLE VERSIONS

AD12650/W4, catalogue number 2422 257 31431 }
 AD12650/W8, catalogue number 2422 257 31432 }

these numbers apply to bulk packed loudspeakers, minimum packing quantity 4 per unit.

FREQUENCY RESPONSE CURVES (see Fig.2)

Measured in anechoic room at the operating power. Loudspeaker mounted in sealed 80 l enclosure, filled with 0,5 kg of glasswool.

Curve a: Sound pressure.

Curves d2 and d3: 2nd and 3rd harmonic distortion.



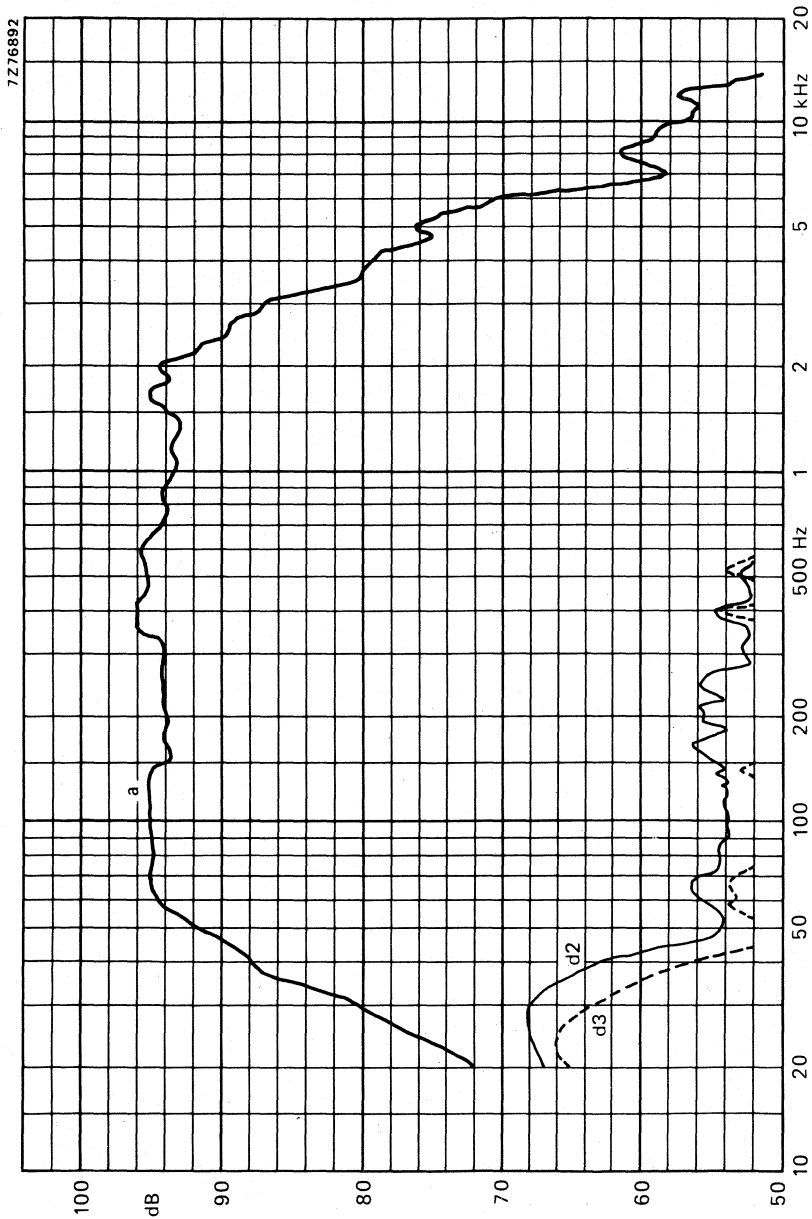

Fig. 2.



ACCESSORIES



Passive radiators

8 INCH PASSIVE RADIATORS

APPLICATION

To be used in combination with loudspeaker AD80651/W. and AD80652/W. respectively, in a sealed 35 l enclosure for an improved bass response.

TECHNICAL DATA

Effective area	$2,2 \times 10^{-2} \text{ m}^2$
Moving mass:	
tuned mass	24,1 g
cone mass	7,0 g
total moving mass	33,9 g
Speed of displacement	100 mm/s
Static compliance	1,6 mm/N
Mass of radiator	238 g

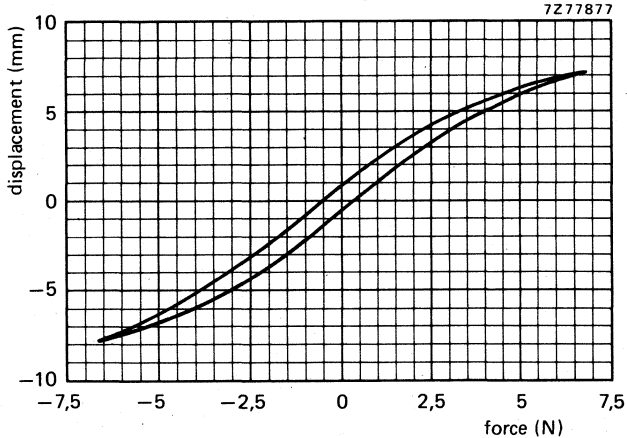

Type AD8001 is equipped with a rubber surround and is matching loudspeaker AD80651/W., type AD8002 is equipped with a polyester surround and is matching loudspeaker AD80652/W..

AD8001
AD8002

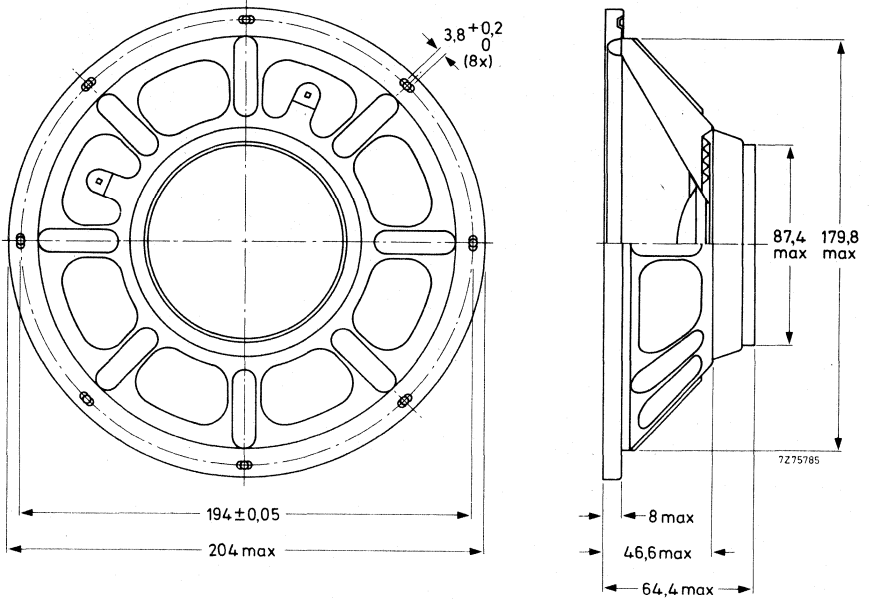

AVAILABLE VERSIONS

rubber surround

AD8001 catalogue number 2404 259 80021

polyester surround

AD8002 catalogue number 2404 259 80022

} these numbers apply to bulk packed radiators, minimum packing quantity 14 per unit.



12 INCH PASSIVE RADIATOR

APPLICATION

To be used in combination with loudspeaker AD12200/W. in a sealed 100 l enclosure for an improved bass response.

TECHNICAL DATA

Effective area	$5 \times 10^{-2} \text{ m}^2$
Moving mass:	
tuned mass	24,1 g
cone mass	15 g
total moving mass	51,6 g
Speed of displacement	100 mm/s
Static compliance	2,55 mm/N
Mass of radiator	710 g

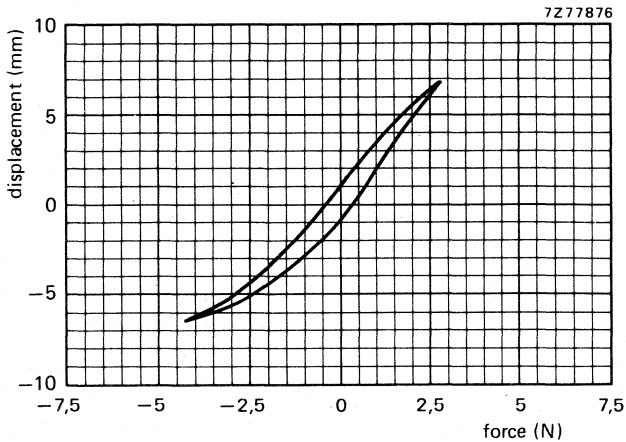

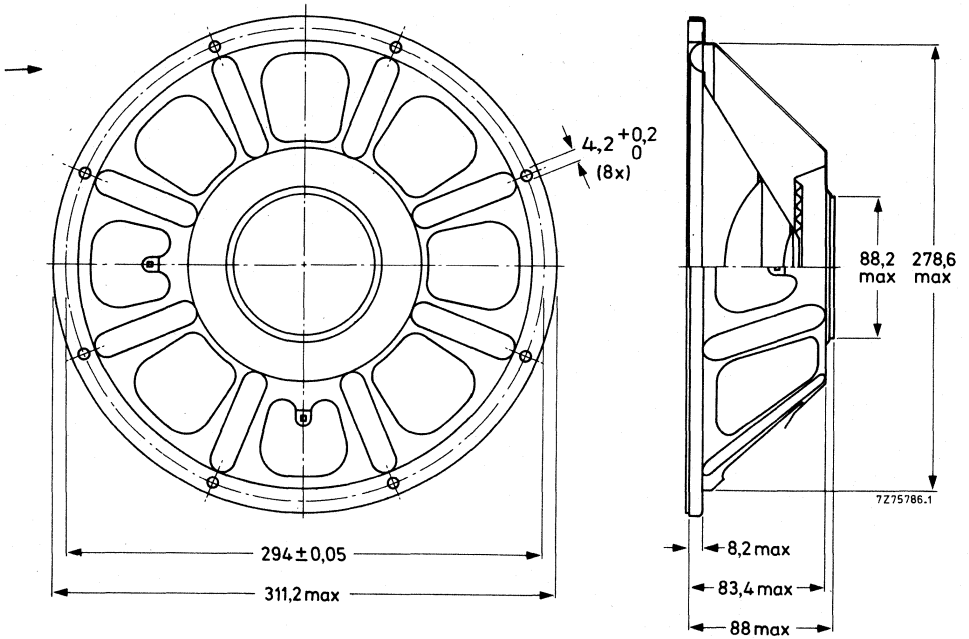

AVAILABLE VERSION

AD1200 catalogue number 2422 259 12021

this number applies to bulk packed radiators, minimum packing quantity 3 per unit.





GENERAL (WITH SURVEY)

LOW POWER

MEDIUM POWER

HIGH POWER FULL RANGE

HIGH POWER TWEETERS

HIGH POWER SQUAWKERS

HIGH POWER WOOFERS

ACCESSORIES

Argentina: FAPESA I.y.C., Av. Crovara 2550, Tablada, Prov. de BUENOS AIRES, Tel. 652-7438/7478.

Australia: PHILIPS INDUSTRIES HOLDINGS LTD., Elcoma Division, 67 Mars Road, LANE COVE, 2066, N.S.W., Tel. 427 08 88.

Austria: ÖSTERREICHISCHE PHILIPS BAUELEMENTE Industrie G.m.b.H., Triester Str. 64, A-1101 WIEN, Tel. 62 91 11.

Belgium: M.B.L.E., 80, rue des Deux Gares, B-1070 BRUXELLES, Tel. 523 00 00.

Brazil: IBRAPE, Caixa Postal 7383, Av. Brigadeiro Faria Lima, 1735 SAO PAULO, SP, Tel. (011) 211-2600.

Canada: PHILIPS ELECTRONICS LTD., Electron Devices Div., 601 Milner Ave., SCARBOROUGH, Ontario, M1B 1M8, Tel. 292-5161.

Chile: PHILIPS CHILENA S.A., Av. Santa Maria 0760, SANTIAGO, Tel. 39-40 01.

Colombia: SADAPE S.A., P.O. Box 9805, Calle 13, No. 51 + 39, BOGOTA D.E. 1., Tel. 600 600.

Denmark: MINIWATT A/S, Emdrupvej 115A, DK-2400 KØBENHAVN NV., Tel. (01) 69 16 22.

Finland: OY PHILIPS AB, Elcoma Division, Kaivokatu 8, SF-00100 HELSINKI 10, Tel. 1 72 71.

France: R.T.C. LA RADIOTECHNIQUE-COMPELEC, 130 Avenue Ledru Rollin, F-75540 PARIS 11, Tel. 355-44-99.

Germany: VALVO, UB Bauelemente der Philips G.m.b.H., Valvo Haus, Burchardstrasse 19, D-2 HAMBURG 1, Tel. (040) 3296-1.

Greece: PHILIPS S.A. HELLENIQUE, Elcoma Division, 52, Av. Syngrou, ATHENS, Tel. 915 311.

Hong Kong: PHILIPS HONG KONG LTD., Elcoma Div., 15/F Philips Ind. Bldg., 24-28 Kung Yip St., KWAI CHUNG, Tel. 12-24 51 21.

India: PEICO ELECTRONICS & ELECTRICALS LTD., Ramon House, 169 Backbay Reclamation, BOMBAY 400020, Tel. 295144.

Indonesia: P.T. PHILIPS-RALIN ELECTRONICS, Elcoma Div., Panim Bank Building, 2nd Fl., Jl. Jend. Sudirman, P.O. Box 223, JAKARTA, Tel. 716 131.

Ireland: PHILIPS ELECTRICAL (IRELAND) LTD., Newstead, Clonskeagh, DUBLIN 14, Tel. 69 33 55.

Italy: PHILIPS S.p.A., Sezione Elcoma, Piazza IV Novembre 3, I-20124 MILANO, Tel. 2-6994.

Japan: NIHON PHILIPS CORP., Shuwa Shinagawa Bldg., 26-33 Takanawa 3-chome, Minato-ku, TOKYO (108), Tel. 448-5611.
(IC Products) SIGNETICS JAPAN, LTD. TOKYO, Tel. (03)230-1521.

Korea: PHILIPS ELECTRONICS (KOREA) LTD., Elcoma Div., Philips House, 260-199 Itaewon-dong, Yongsan-ku, C.P.O. Box 3680, SEOUL, Tel. 794-4202.

Malaysia: PHILIPS MALAYSIA SDN. BERHAD, Lot 2, Jalan 222, Section 14, Petaling Jaya, P.O.B. 2163, KUALA LUMPUR, Selangor, Tel. 77 44 11.

Mexico: ELECTRONICA S.A. de C.V., Varsovia No. 36, MEXICO 6, D.F., Tel. 533-11-80.

Netherlands: PHILIPS NEDERLAND B.V., Afd. Elonco, Boschdijk 525, 5600 PB EINDHOVEN, Tel. (040) 79 33 33.

New Zealand: PHILIPS ELECTRICAL IND. LTD., Elcoma Division, 2 Wagener Place, St. Lukes, AUCKLAND, Tel. 867 119.

Norway: NORSK A/S PHILIPS, Electronica, Særkedalsveien 6, OSLO 3, Tel. 46 38 90.

Peru: CADESA, Rocca de Vergallo 247, LIMA 17, Tel. 62 85 99.

Philippines: PHILIPS INDUSTRIAL DEV. INC., 2246 Pasong Tamo, P.O. Box 911, Makati Comm. Centre, MAKATI-RIZAL 3116, Tel. 86-89-51 to 59.

Portugal: PHILIPS PORTUGESA S.A.R.L., Av. Eng. Duharte Pacheco 6, LISBOA 1, Tel. 68 31 21.

Singapore: PHILIPS PROJECT DEV. (Singapore) PTE LTD., Elcoma Div., Lorong 1, Toa Payoh, SINGAPORE 1231, Tel. 25 38 811.

South Africa: EDAC (Pty.) Ltd., 3rd Floor Rainer House, Upper Railway Rd. & Ove St., New Doornfontein, JOHANNESBURG 2001, Tel. 614-2362/9.

Spain: COPRESA S.A., Balmes 22, BARCELONA 7, Tel. 301 63 12.

Sweden: A.B. ELCOMA, Lidingsvägen 50, S-115 84 STOCKHOLM 27, Tel. 08/67 97 80.

Switzerland: PHILIPS A.G., Elcoma Dept., Allmendstrasse 140-142, CH-8027 ZÜRICH, Tel. 01/43 22 11.

Taiwan: PHILIPS TAIWAN LTD., 3rd Fl., San Min Building, 57-1, Chung Shan N. Rd, Section 2, P.O. Box 22978, TAIPEI, Tel. 5513101-5.

Thailand: PHILIPS ELECTRICAL CO. OF THAILAND LTD., 283 Siom Road, P.O. Box 961, BANGKOK, Tel. 233-6330-9.

Turkey: TÜRK PHILIPS TICARET A.S., EMET Department, Inonu Cad. No. 78-80, ISTANBUL, Tel. 43 59 10.

United Kingdom: MULLARD LTD., Mullard House, Torrington Place, LONDON WC1E 7HD, Tel. 01-580 6633.

United States: (Active devices & Materials) AMPEREX SALES CORP., Providence Pike, SLATERSVILLE, R.I. 02876, Tel. (401) 762-9000.
(Passive devices) MEPCO/ELECTRA INC., Columbia Rd., MORRISTOWN, N.J. 07960, Tel. (201) 539-2000.
(IC Products) SIGNETICS CORPORATION, 811 East Arques Avenue, SUNNYVALE, California 94086, Tel. (408) 739-7700.

Uruguay: LUZILECTRON S.A., Avda Rondeau 1576, piso 5, MONTEVIDEO, Tel. 91 43 21.

Venezuela: IND. VENEZOLANAS PHILIPS S.A., Elcoma Dept., A. Ppal de los Ruices, Edif. Centro Colgate, CARACAS, Tel. 36 05 11.